

AERONAUTICAL DICTIONARY

NATIONAL AERONAUTICS AND SPACE ADMINISTRATION

AERONAUTICAL DICTIONARY



NASA

NATIONAL AERONAUTICS AND SPACE ADMINISTRATION

AERONAUTICAL DICTIONARY

by

FRANK DAVIS ADAMS



UNITED STATES
GOVERNMENT PRINTING OFFICE
WASHINGTON : 1959

For sale by the Superintendent of Documents, U. S. Government Printing Office
Washington 25, D. C. Price \$1.75

Some Abbreviations Used in this Dictionary

AF— <i>United States Air Force.</i>	intr.— <i>intransitive.</i>
Av. med.— <i>Aviation medicine.</i>	Med.— <i>Medicine.</i>
c.— <i>copyright.</i>	Meteorol.— <i>Meteorology.</i>
c.— <i>circa.</i>	Nav.— <i>Navigation.</i>
cf.— <i>compare.</i>	Obs.— <i>Obsolete.</i>
disting.— <i>distinguished.</i>	phr.— <i>phrase.</i>
e. g.— <i>for example.</i>	specif.— <i>specifically.</i>
esp.— <i>especially.</i>	tr.— <i>transitive.</i>
i. e.— <i>that is.</i>	WW— <i>World War.</i>
illus.— <i>illustration.</i>	

ii

Acknowledgments

The writer of this Dictionary has been given excellent and whole-hearted cooperation, advice, and encouragement by members of this organization from the highest echelon downward, reflecting the general interest in the project. Some of the individuals to whom particular indebtedness is acknowledged are to be mentioned here. (All of the persons named hereafter are of this organization unless otherwise indicated.)

Primary indebtedness is acknowledged to Dr. James A. Hootman, under whose capable supervision the Dictionary evolved. In addition to serving as supervisor, Dr. Hootman, a physicist as well as a lexicographer in his own right, served as an authority on matters of general science and gave invaluable help and advice on the format, approach, and coverage of the Dictionary.

The writer was aided in his work to no small extent by a number of preliminary definitions prepared by Mr. Maurice Munger. The information contained in these definitions (reviewed and annotated by Dr. Hootman) and their manner of arrangement considerably alleviated the tasks of research and collation.

Of the many consulting specialists, the following scientists and engineers deserve special mention for extraordinary zeal and outstanding assistance: Dr. Samuel Katzoff and Mr. Albert J. Evans (Aerodynamics); Mr. William H. Phillips (Stability and Control); Mr. Frederic B. Gustafson (Rotary-wing Aircraft); and Mr. Philip Donely (Structures).

Other consulting specialists on the technical accuracy of the definitions include: Messrs. Henry C. Barnett, Edmond E. Bisson, Jack D. Brewer, Harvey H. Brown, Mason T. Charak, Blake W. Corson, Jr., Howard J. Curfman, Jr., Eugene L. Davis, Jr., Albert E. von Doenhoff, Benson E. Gammon, Alfred Gessow, William Gracey, William L. Jones, Powell M. Lovell, Jr., George F. MacDougall, Bernard Maggin, Donald L. Mallick, Boyd C. Myers, II, David Novik, E. O. Pearson, Jr., Richard H. Raring, John P. Reeder, Richard V. Rhode, Melvin G. Rosche, Joseph A. Shortal, Robert W. Sommer, James W. Useller, Jr., Fred Voss, Curtis L. Walker (now of Allison Division of General Motors Corporation), James M. Watson, Stafford W. Wilbur, Clotaire Wood, and John A. Zalovcik. Of the consulting specialists the writer has been able to name only those with whom he has had personal contact, and hopes that this blanket note of acknowledgement will suffice for all others who have given so generously of their time and knowledge.

Special recognition is given to Mr. Charles H. Sturges, Jr., who prepared the illustrations for the Dictionary.

Administrative, technical, and research assistance were also provided by Miss Grace Bogart, NASA Headquarters Library; Captain Walter S. Diehl (U. S. N., Ret.); Mr. Jesse H. Hall, now Chief, Instrument and Computing Research Division, Lewis Research Center; Captain

iii

Grayson Merrill (U. S. N., Ret., now of the Guided Missiles Division, Fairchild Engine and Airplane Corporation); Mr. Jules M. Miller, now Technical Staff Assistant, Langley Research Center; Commander (now Captain) Donald J. O'Meara, formerly of the Airship Design Branch, Bureau of Aeronautics; Mr. Lee M. Pearson and Mr. Alfred V. Ver-ville, Bureau of Aeronautics; and Mr. R. L. Wilson, formerly of the Airship Design Branch.

Finally, a word of appreciation is owing to the two secretaries who served on the project at different times, Mrs. Lois E. De Neale and Miss Judith Lindner (now Mrs. Judith Promisel of Baltimore); for their reliability, patience, and general capability the lexicographer's warmest gratitude.

Preface

This Dictionary appears in response to numerous requests, culminated by a formal request from the Department of Defense, for a comprehensive, authoritative aeronautical dictionary. The project was at first envisioned as an extensive revision of NACA Report Number 474, the "Nomenclature for Aeronautics," last revised in 1933. After some work was done in this direction, it came to be realized that the aeronautical field was now so large, that it had expanded to such a great extent in the last twenty-five years, that a completely new *dictionary* was indicated, rather than a mere revision, however elaborate, of the old "Nomenclature."

It is expected that this Dictionary will have a wide and varied audience; thus, while many technical terms do not lend themselves to simple definition, a deliberate effort has been made to couch the definitions in language understandable to the novice and interested nonprofessional without at the same time doing violence to the sensibilities of the professional. While the writer is aware that there are those who expect of a dictionary information and an approach more properly peculiar to a textbook or to a book of standards, this Dictionary reflects a growing appreciation on the part of the more thoughtful scientist and engineer of the nature of language and of the purposes of a dictionary. A dictionary, properly, is a mirror of good usage; accordingly, this Dictionary is constructed upon tried lexicographic principles, using a foundation of more than 100,000 citations (examples of usage) culled from the literature of aeronautics and related fields. (See the *Bibliography*.) Thus a dictionary, as a "mirror of usage," is intended to stabilize rather than standardize the language, for language is an ever-growing entity, with new terms always being created and new meanings and extensions of old meanings constantly being added to existing terms.

As an *aeronautical* dictionary, this lexicon includes in addition to aeronautical terms only certain fundamental terms in related fields, such as navigation and meteorology, for such fields as these require, and indeed have, dictionaries of their own. Certain terms from the basic discipline of physics (such as *Bernoulli's law*, *Coriolis effect*) are included for their importance in the aeronautical field, with the emphasis always upon the application in aeronautics of the phenomenon described. Terms in the province of military (including naval) aeronautics are included only if they are of such currency and general interest (e. g., *bomber*, *squadron*) as to make their inclusion desirable, such terms always being given general definition herein. The border line between aeronautics and space technology is not always easy to define, and many terms are, or can be, applied in both areas; consequently, the definitions given these terms herein are worded so as to take account of application in either field. See, for example, *ANGLE OF YAW*, *FLY*. Many terms in the fields of rocketry and missilery are also included.

In the main, the approach and typography of this work will become evident to the user through familiarity; some brief introductory remarks upon the use and interpretation of the Dictionary should, however, be helpful in this place.

Each entry is identified as to its part of speech, with the exception of nonjoined compound nouns and noun phrases. Many words, compounds, and phrases considered self-explanatory or otherwise not deserving separate entry are given in **boldface** under the significant entry, or, where an adjective is the main entry, given as illustrative phrases; see, for example, **AERIAL**, **AXIAL-FLOW ENGINE**, **DEAD STICK**, **FEEDER AIRLINE**, **POWER DIVE**. In the case of synonymous terms, the preferred term is the term which the evidence indicates is the more frequently used (provided, generally, that the term is acceptable with respect to logic and consistency), and is the term under which the definition is given. In dual entries, as to whether a compound is written solid, hyphenated, or not joined, the first-entered form is preferred (see **CENTER LINE**). Verbs with both transitive and intransitive uses given have the more common usage, ordinarily the transitive, defined first. Many definitions of transitive verbs show the typical objects in parentheses.

The pronunciation is indicated for some few terms of which the pronunciation may be questioned.

A label on a meaning (e. g., *Rare*, *Slang*) refers only to that meaning on which the label appears, not to any meanings of the same term that may precede the labeled meaning.

Since this Dictionary is not intended to supplant standard dictionaries or technical dictionaries in other fields, it must be understood that many terms herein have meanings other than those given, but of no particular significance in aeronautics; thus the nouns **attitude**, **flight**, and **loop** and the verb **sail**, to mention only a few of many examples, are defined only with reference to aeronautics, other meanings being ignored. On the other hand, where it is convenient or otherwise desirable, a term may be given a general definition with its application in aeronautics usually stressed, as in **engine** and **inlet**. A definition may be preceded by "specif." (for *specifically*) if the term it defines has, or could conceivably have, some other, but not particularly significant, usage in aeronautics (see **PACKAGE**); "specif." or "esp." (for *especially*) is also used to isolate a specific or often-used meaning within a general definition. See, for example, **AIRCRAFT MECHANIC**, **CRITICAL ANGLE OF ATTACK**. Some common terms not having unusual signification in aeronautics, such as **angle** or **duct**, are included and defined for the sake of convenience to the user because of their frequent occurrence in the aeronautical language or for the sake of serving as a gathering point for cross references. Terms such as **abeam** and **dashboard** are included to show their application in aeronautics, not usually pointed out or stressed in other dictionaries.

A standard lexicographic device to aid in understanding a term is to show the term used in context; consequently, examples of usage occur frequently in the definitions given in this Dictionary. Such examples, with the exception of attributive adjectives, are always preceded by "as" followed by a comma when incorporated in the definition proper, or are sometimes set off as quotes in notes; illustrative examples of usage of attributive adjectives are preceded by "as in." See, for example, **AIRFOIL**, **FLIGHT**, **SUPERSONIC**.

The different meanings for a given term are separated by number, letter, or by the semicolon. The letters are used as subheadings under a numbered heading or are used to indicate a close relation between the different meanings. The semicolon is used to indicate an even closer relation between the senses, to set off a specification of meaning, or to set off a subsense from a more accurate or more general sense; rarely, it is used to separate examples of usage.

The Dictionary has many cross references, usually printed in **SMALL CAPITAL LETTERS**. (A term printed in **SMALL CAPITALS** is *always* a cross reference, whether or not it is preceded by "see" or "cf.") These cross references should prove useful to the librarian and the cataloguer as well as to the general user.

No effort has been spared in striving for accuracy, first, in the analysis of citations for meaning and shadings of meaning; second, in library research effort; third, in consultation with various scientists, engineers, and other professionals, chiefly among the personnel of the NACA-NASA (see *Acknowledgments*); and fourth, in the writing and proofreading of the definitions. Room doubtless remains, however, for constructive criticism, and such criticism is welcomed. In those cases where the reader may find a meaning omitted, he is urged to accompany a recommendation for the inclusion of the additional meaning with a clearly illustrative example of usage from the literature or with reference to acceptable authority.

F. D. A.
National Aeronautics and Space Administration,
Washington, D.C.

Aeronautical Dictionary

A

abeam, adv. By or to the side of—applied to aircraft, as, the missile passed *abeam* of the airplane.

aboard, adv. In or on a ship, aircraft, or other conveyance.

abort, noun. 1. An act or instance of aborting. 2. An aircraft, guided missile, or the like that aborts, as, ten of the bombers became *aborts*.

abort, verb. *Chiefly in military usage:* 1. *tr.* To cut short or break off (an action, operation, or procedure) with an aircraft, guided missile, or the like, esp. because of equipment failure, as, to *abort* a mission, or, the launching was *aborted*. 2. *intr.* To break off short of the completion or fulfillment of an action, operation, or procedure.

abreast, adv. Side by side—applied to aircraft.

absolute altimeter. An altimeter, such as a radio altimeter, designed to give acceptably accurate, direct indications of absolute altitude.

absolute altitude. Altitude above the actual surface of the earth, either land or water. Cf. TRUE ALTITUDE.

absolute angle of attack. An angle of attack measured between a reference line in an airfoil and the position the reference line would have if the airfoil were producing zero lift, i.e., the sum of the geometric angle of attack and the zero lift angle of attack. Also called an "aerodynamic angle of attack." See ANGLE OF ATTACK, sense 1.

absolute ceiling. The maximum height above sea level in a standard atmosphere at which a given airplane under specified operating conditions can maintain horizontal flight.

absolute humidity. The amount of water vapor actually present in an atmosphere, expressed, e. g., by its weight in grains per cubic foot.

accelerated stall. A stall with an airplane under acceleration, as in a pull-out. Such a stall usually produces more violent motions of the airplane than does a stall occurring in unaccelerated flight.

accelerating pump. A pump in a carburetion system that momentarily enriches the fuel-air mixture when the throttle is opened suddenly. The pump may be of the plunger type, operated by the throttle, or it may be of the diaphragm type, automatically operated by variation of the air pressure in the induction system. See ACCELERATING WELL.

accelerating well. A well or reservoir in a carburetor, holding a supply of fuel to enrich the mixture when the throttle is opened suddenly. The fuel is drawn from the well by increased suction in the carburetor venturi. See ACCELERATING PUMP.

acceleration, noun. 1. In mechanics, a change in the velocity of a body, or the rate of such change, with respect to speed or direction, or both, as, *accelerations* occur during catapult take-offs and crash landings, or, gusts impose a series of sharp *accelerations* on an airplane; the state or condition of a body undergoing such change. 2. In a more restricted sense but more popular usage, the act or process of moving, or of causing to move, with increasing speed; the state or condition of so moving. Cf. DECELERATION. 3. a. A force causing acceleration. b. An inertial force. See final note.

See ANGULAR ACCELERATION, IMPACT ACCELERATION, LATERAL ACCELERATION, LINEAR ACCELERATION, LONGITUDINAL ACCELERATION, NEGATIVE ACCELERATION, POSITIVE ACCELERATION, TRANSVERSE ACCELERATION, VERTICAL ACCELERATION.

Senses 3a and 3b are sometimes difficult if not impossible to distinguish, as in "The

turn imposed a severe *acceleration* on the airplane." The ambiguity of the word in these senses is also evident in the terms "head-to-seat acceleration," "foot-to-head acceleration," etc., where the user sometimes considers "acceleration" to mean "inertial force." For example, if one considers the pilot of an airplane to be undergoing a head-to-seat acceleration in a pull-out from a dive, he is clearly identifying "acceleration" with "inertial force"; but in these terms usage in sense 3b is less common than in sense 3a. See FOOT-TO-HEAD ACCELERATION, HEAD-TO-FOOT ACCELERATION, HEAD-TO-SEAT ACCELERATION, SEAT-TO-HEAD ACCELERATION.

accelerometer, noun. An instrument or device, often mounted in an aircraft, guided missile, or the like, that senses and responds to accelerative forces, usually for purposes of measuring, indicating, or recording such forces.

Some types of accelerometers measure linear accelerative forces, while others measure angular accelerative forces. Certain types are sometimes employed in control systems and circuits to govern control action automatically. A common type of accelerometer is that used aboard aircraft to record the vertical accelerations (in terms of *g*'s) to which the aircraft is subjected during flight. See INTEGRATING ACCELEROMETER.

accessory, noun. Any apparatus, article, device, system, or fixture, often an attachment, that contributes to the use, efficiency, effectiveness, safety, or convenience of another thing, but which is not essential to the full identity of the object to which it is attached or with which it is used, and which is often not essential to the fundamental operation of the primary object. With regard to aircraft, two categories of accessories are generally recognized: aircraft accessories and engine accessories. See AIRCRAFT ACCESSORY, ENGINE ACCESSORY.

accessory section. A particular section of certain aircraft engines on which some important engine accessories are mounted. This section is usually located at the rear of in-line and radial piston engines, and at or toward the front of gas-turbine engines.

accumulator, noun. A device or apparatus that accumulates or stores up, as: a. A contrivance in a hydraulic system that stores fluid under pressure. b. A device sometimes incorporated in the fuel system of a gas-turbine engine to store up and release fuel under pressure as an aid in starting.

accuracy landing. A landing in which the pilot sets, or strives to set, his aircraft down on a particular spot or place in the proper or normal gliding

and landing attitude, usually following a prescribed flight path or pattern. Also called a "precision landing." See SPOT LANDING.

acrobatics, noun. In specific senses: 1. AEROBATICS (in sense a or sense b). 2. a [Construed as a singular.] The performance of stunts or gymnastic feats on an aircraft in flight, such as wing walking, trapeze swinging, etc. b. [Construed as a plural.] The stunts or feats so performed.

In sense 1, "acrobatics" is construed in both singular and plural like "aerobatics."

active homing. The homing (which see) of a guided missile in which energy waves (as radar) are transmitted from the missile to the target and reflected back to the missile to direct the missile toward the target.

actual brake horsepower. The brake horsepower output of an engine, uncorrected for the prevailing operating conditions. Also called the "observed brake horsepower." See BRAKE HORSEPOWER.

actuator disk. A concept used in the momentum theory of propeller or rotary-wing action, in which the rotating propeller or rotor is regarded as composed of an infinite number of blades (hence becoming a disk) capable of accelerating the air uniformly through the blades or disk with no air losses at the blade tips, or periphery of the disk.

adapter, noun. 1. Any device or contrivance used or designed primarily to fit or adjust one thing to another, as: a. A buckle or clip on a parachute harness, used in adjusting the harness to the wearer. b. A joint attaching an afterburner to a turbine casing on a jet engine. c. A fitting for connecting pipes, valves, etc. that have different types of threads. d. A CARBURETOR ADAPTER. 2. Any device, appliance or the like used to alter something so as to make it suitable for a use for which it was not originally designed, such as a fabric device used to render a barrier on an aircraft carrier capable of handling airplanes equipped with tricycle landing gears.

Adcock radio range. [After Frank Adcock (1892-), English engineer.] A type of radio range utilizing four vertical antennas (Adcock antennas) placed at the corners of a square, with a fifth antenna at the center of the square.

The radiation pattern and signals of the Adcock radio range are similar to those of the loop-type radio range, but the Adcock range permits simultaneous voice and range transmissions, produces a constant carrier wave for use with direction-finding equipment, and has fewer of the irregularities inherent in the loop-type range. See LOOP-TYPE RADIO RANGE.

additional apparent mass. Same as APPARENT ADDITIONAL MASS.

additive, noun. Any material or substance added to something else; specif., any material or substance added to fuels or lubricants to improve them or give them some desired quality, such as tetraethyl lead, added to fuel as an antidetonation agent, or graphite, talc, or other substances added to certain oils and greases to improve lubrication qualities.

ADF—Abbreviation for *automatic direction finder* or *automatic direction finding*.

Often used in compounds, such as ADF bearing, ADF needle, ADF receiver, etc.

ADF reversal. The swinging of the needle on the direction indicator of an automatic direction finder from the 0° mark to the 180° mark, indicating that the station to which the direction finder is tuned has been passed.

adiabatic efficiency. The efficiency with which work is done with respect to heat gains or losses.

adjustable-area exhaust nozzle. Same as VARIABLE-AREA EXHAUST NOZZLE.

adjustable-pitch propeller. A propeller the blade angle of which may be varied only with the propeller at rest, by manual loosening of locks or clamps and turning the propeller blades in their hub. Cf. CONTROLLABLE-PITCH PROPELLER.

adjustable stabilizer. A stabilizer, esp. a horizontal stabilizer, whose angle of incidence may be varied, usually both on the ground and in flight. See CONTROLLABLE, note.

advancing blade. On a rotary-wing aircraft in horizontal motion, a rotor blade or wing moving against or into the relative wind. With a rotary-wing aircraft in forward motion, a blade is considered advancing as it moves from

its extreme aft position to its extreme forward position. Cf. RETREATING BLADE.

advancing edge. A LEADING EDGE. *Obs.* adverse pressure gradient. In a fluid flow system or field, a pressure gradient of increasing static pressure in the direction of the flow. Cf. FAVORABLE PRESSURE GRADIENT.

adverse yaw. Yaw in the opposite sense to that of the roll of an aircraft, e. g., a yaw to the left with the aircraft rolling to the right. Cf. FAVORABLE YAW.

aerial, adj. In specific senses: 1. a. Taking place, performed, or conducted in the air, or carried out by aircraft, as in *aerial demonstration*, *aerial flight*, *aerial navigation*, *aerial refueling*, *aerial warfare*; coming or done from the air, or done by aircraft, as in *aerial bombardment*, *aerial dusting*, *aerial mapping*, *aerial photography*. b. Made or done in or from the air, as in *aerial photograph*. 2. Designed to be used in or from the air, or to be used by aircraft, as in *aerial camera*, *aerial cannon*, *aerial mine*. 3. Of or pertaining to aircraft, or to the air conceived as a realm, as in *aerial preparedness*. 4. Operating or traveling in the air, or designed to operate or travel in the air, as in *aerial experiment station*, *aerial vehicle*. 5. Of persons: Using, or skilled in using, the air or aircraft as a medium for, or means of, travel, fighting, or other activities, as in *aerial explorer*, *aerial navigator*, *aerial tactician*; operating in or from the air, or in aircraft, as in *aerial gunner*. 6. Established or existing in the air, as in *aerial highway*, *aerial lane*, *aerial traffic*.

aerial acrobat. A person who performs acrobatics (in sense 2b, which see) on an aircraft in flight. Cf. STUNT FLIER.

aerial photograph. A photograph of the earth's surface taken from an aircraft in flight. See OBLIQUE AERIAL PHOTOGRAPHY, VERTICAL AERIAL PHOTOGRAPHY.

aerial target. A target designed to be towed or flown in the air, and used in air-to-air or surface-to-air gunnery training; specif., a TOW TARGET.

In its broad meaning, "aerial target" is applied both to tow targets and to pilotless, remote-controlled aircraft designed or used as targets.

aerial torpedo. A name applied to an early type of explosive-laden pilotless airplane with preset control. See **FLYING BOMB**.

aero, adj. 1. a. Of, pertaining to, or interested in, aeronautics, as in *aero* society. b. Designed or developed for aircraft, as in *aero* engine. 2. Of or pertaining to air, as in *aero* mixture indicator.

aero-, combining form. 1. a. Denoting or pertaining to air, or to the physical properties or effects of air (or sometimes other gases), as in *aerodynamics*, *aeroelasticity*, *aerosinusitis*, *aerothermodynamics*. b. Pertaining to the atmosphere, as in *aeropause*. 2. Aerial, aeronautical, as in *aeronavigation*, *aerodrone*, *aeromedical*, *aerotechnical*.

aerobatic, adj. a. Pertaining to, or characterized by, aerobatics. b. Capable of performing, or designed for use in, aerobatics—applied to aircraft or aircraft components, as, the plane is *aerobatic*, or as in *aerobatic* seat.

aerobatics, noun. a. [Construed as a singular.] The performance of stunts, such as dives, loops, steep banks, rolls, etc., in an aircraft, esp. in an airplane or glider. b. [Construed as a plural.] The stunts so performed.

aerodrome, noun. 1. Variant of "air-drome." *Now chiefly British.* 2. A term introduced by S. P. Langley (c. 1893) for a heavier-than-air aircraft; specif., the name applied to the full-size airplane or to any of the model airplanes made by Langley. *Archaic.*

aerodynamic, adj. Of or pertaining to aerodynamics.

aerodynamical, adj. Same as **AERODYNAMIC**. *Rare.*

aerodynamic angle of attack. Same as **ABSOLUTE ANGLE OF ATTACK**.

aerodynamic axis. The axis is an airfoil, or other body, containing the aerodynamic centers of the body, such as the line joining the aerodynamic centers along a wing span.

aerodynamic balanced surface. A control surface so designed or fitted out with auxiliary devices that the magnitude of the aerodynamic moment about the hinge axis is reduced. See **HORN BALANCE**, **INTERNAL BALANCE**.

aerodynamic center. A point in a cross section of an airfoil or other aerodynamic body or combination of bodies,

about which the pitching moment remains practically constant with nearly all changes in angle of attack.

aerodynamic coefficient. Any nondimensional coefficient relating to aerodynamic forces or moments, such as a coefficient of drag, a coefficient of lift, etc.

aerodynamic condensation trail. A condensation trail caused aerodynamically. See **CONDENSATION TRAIL** and **note**.

aerodynamic drag. Drag caused by aerodynamic forces.

The term "aerodynamic drag" is used esp. to distinguish such drag from other kinds of drag, such as the hydrodynamic drag acting on seaplane hulls or floats.

aerodynamic efficiency. The efficiency with which a body overcomes or makes use of aerodynamic forces or actions; specif., the efficiency with which an airfoil or other lifting body produces lift in proportion to drag, determined numerically from the lift-drag ratio (L/D).

aerodynamic heating. The heating of a body produced by passage of air or other gases over the body, significant chiefly at high speeds, caused by friction and by compression processes.

aerodynamic lift. Lift resulting from aerodynamic forces. See **LIFT**, **sense 1** and **note**.

The term "aerodynamic lift" (or "dynamic lift") is encountered esp. in airship contexts, to distinguish the lift created by the dynamic action of the air against the airship hull from the aerostatic lift.

aerodynamic load. A load (in **sense 2**, which see) imposed by aerodynamic action, such as a load imposed by aerodynamic lift or drag.

aerodynamic missile. A missile that utilizes aerodynamic lift for support in flight.

aerodynamic overbalance. A condition existing when aerodynamic forces cause an aircraft or aircraft component to rotate or turn excessively about a point or line; specif., the condition of an aircraft control surface existing when its deflection results in a hinge moment tending to increase the deflection.

aerodynamics, noun. [Usually construed as a singular.] 1. The science that treats of the motion of air and other gaseous fluids, and of the forces acting on bodies when the bodies move through such fluids, or when such

fluids move against or around the bodies, as, his research in *aerodynamics*.

2. a. The actions and forces resulting from the movement or flow of gaseous fluids against or around bodies, as, the *aerodynamics* of a wing in supersonic flight. b. The properties of a body or bodies with respect to these actions or forces, as, the *aerodynamics* of a turret, or of a configuration. 3. The application of the principles of gaseous fluid flows and of their actions against and around bodies to the design and construction of bodies intended to move through such fluids, as, a design used in *aerodynamics*.

aerodynamic stability. The stability of a body with respect to aerodynamic forces.

aerodynamic torque. Torque exerted on something, esp. a propeller or rotor, by aerodynamic forces.

aerodynamic twist. The twist of an airfoil having different absolute angles of attack at different spanwise stations.

An airfoil may have both aerodynamic twist and geometric twist; however, an airfoil with zero geometric twist will have aerodynamic twist if the zero-lift angles of attack for different sections are not the same. On the other hand, such an airfoil can be geometrically twisted to make the aerodynamic twist zero. Cf. **GEOMETRIC TWIST**.

aerodynamic volume. Same as **AIR VOLUME**.

aerodynamic washin. Washin (which see) with respect to absolute angles of attack.

aerodynamic washout. Washout (which see) with respect to absolute angles of attack.

aerodyne, noun. Any aircraft that derives all of its lift from aerodynamic forces. Cf. **AEROSTAT**.

aeroelasticity, noun. 1. The quality or state of an elastic structure acted upon by aerodynamic forces. 2. The study of the effect of aerodynamic forces on elastic bodies.

aeroembolism, noun. Med. 1. The formation or liberation of gases in the fluids and tissues of the body, as brought on esp. by a too-rapid change from a high, or relatively high, atmospheric pressure to a lower one. 2. The disease or condition caused by the formation or liberation of gases in the body fluids and tissues. The disease is characterized principally by neuralgic

pains, cramps, and swelling, and sometimes results in death. Also called "decompression sickness." Cf. **ALTITUDE SICKNESS** and **BENDS**.

aeroemphysema, noun. Med. A swelling condition caused by aeroembolism in the tissues of the body.

aerograph, noun. Same as **METEOROGRAPH**.

aero-isoclinic, adj. Of an airfoil: That maintains, or tends to maintain, the same angle of attack at all airfoil sections, esp. when flexed or bent.

aerometeorograph, noun. A meteorograph carried aloft by a free balloon, airplane, or other vehicle to measure and record meteorological phenomena.

aeronaut, noun. One who operates, or serves as a crew member on, a free balloon or airship. Cf. **AVIATOR**.

aeronautic, adj. Same as **AERONAUTICAL**. *Rare.*

aeronautical, adj. Of, pertaining to, or used in, aeronautics.

aeronautical chart. A map representing a portion of the earth's land area or land and water area, made specially for use in air navigation.

There are many types of aeronautical charts, constructed on a number of different projections. The ordinary form of aeronautical chart represents several features of aeronautical interest, such as airports, radio ranges, air-navigation aids, danger areas, etc. There are also many different special-purpose aeronautical charts, such as magnetic charts, which show lines of magnetic variation; radio direction-finding charts; great-circle charts; charts made specially for jet aircraft; and others.

aeronautics, noun. The science and art of designing, constructing, and operating aircraft; more narrowly, the science and art of operating aircraft.

aero-otitis media. Med. A condition of the middle ear characterized by congestion, inflammation, and pain, caused by a difference between the air pressure in the tympanic cavity and that of the surrounding air.

aeropause, noun. A region of indeterminate limits in the upper atmosphere, considered as a boundary or transition region between the denser portion of the atmosphere and space. From a functional point of view, it is considered to be that region in which the atmosphere is so tenuous as to have a negligible, or almost negligible, effect on men and aircraft, and in which the physiological requirements of man become increasingly important in the de-

sign of aircraft and auxiliary equipment.

aeroplane, *noun*. 1. Variant of "airplane." *Now chiefly British*. 2. An airfoil, or surface. *Obs.* See PLANE, *noun*, sense 2.

"It was apparent that a propeller was simply an *aeroplane* traveling in a spiral course." Orville Wright.

aeropulse, or aeropulse engine. Same as PULSEJET ENGINE.

aeroresonator, *noun*. Same as RESOJET ENGINE.

aerostat, *noun*. An aircraft that obtains all or most of its lift by virtue of contained air or gas lighter than the surrounding air, i.e., a balloon or airship. Cf. AERODYNE.

aerostatic lift. 1. Lift or buoyancy derived by virtue of a confined air or gas lighter than the surrounding air. 2. The amount of this lift, equal to the difference in weight between a volume of air and an equal volume of the lighter gas, under given conditions.

aerostatics, *noun*. The science that treats of the equilibrium of gaseous fluids, and of the equilibrium and buoyancy of bodies immersed in such fluids.

aerostation, *noun*. The art, science, or practice of operating lighter-than-air aircraft.

aero-thermodynamic duct. The full term for "athodyd" (which see).

aero-tow, *noun*. The act or practice of towing a glider with a powered aircraft.

aft, *adj.* Behind; at or toward the rear, or stern, as in *aft* turret.

aft, *adv.* Near, at, or toward the rear, or stern; rearward—applied to aircraft, as, a parachute stowed *aft*, or, the center of pressure moving *aft*.

afterbody, *noun*. 1. The rear or after portion of a body; a body or component situated aft of another. 2. *Specif.*: a. That portion of a seaplane hull or float of the main step. b. A PROPELLER AFTERBODY.

afterburner, *noun*. An apparatus for augmenting the jet thrust of a gas-turbine engine, consisting essentially of a duct placed aft of the turbine, into which additional fuel is injected and burned in the presence of the uncombined oxygen in the gases from the turbine. Also called a "tailpipe burner."

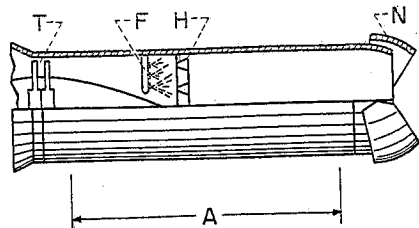

Afterburner (simplified). A afterburner; T turbine; F fuel-spray tubes; H flame holder; N variable-area exhaust nozzle.

aftercooler, *noun*. A cooler in the induction system of an aircraft engine, located between the engine and the supercharger and used to cool the fuel-air mixture after its final stage of compression before entering the engine. Cf. INTERCOOLER.

afterfiring, *noun*. Firing taking place in the cylinders of an engine after the ignition has been shut off.

agricultural aircraft. Aircraft, or an aircraft, designed or equipped for specialized agricultural work, esp. for spraying or dusting crops, seeding, fertilizing, and the like.

ailavator, *noun*. [Aileron + a + elevator.] Same as ELEVON.

aileron, *noun*. 1. A movable control surface or device, one of a pair or set located in or attached to the wings on both sides of an airplane, the primary usefulness of which is controlling the airplane laterally or in roll by creating unequal or opposing lifting forces on opposite sides of the airplane. An aileron commonly consists of a flap-like surface at the rear of a wing, although other devices are sometimes used. 2. The movement or deflection of an aileron, as, to apply slight *aileron*.

In sense 1, see EXTERNAL AILERON, FEELER AILERON, FLAP AILERON, FLOATING AILERON, FRISE AILERON, INTERPLANE AILERON, FLUG AILERON, RETRACTABLE AILERON, SKEWED AILERON, SLOT-LIP AILERON, SLOTTED AILERON, SPOILER AILERON, SPOILER-SLOT AILERON, UPPER-SURFACE AILERON, WING-TIP AILERON.

aileron angle. The angle of displacement of an aileron from its neutral position, considered positive when the aileron is deflected below its neutral position.

aileron buzz. A rapid vibration of an aileron, considered a type of flutter, as occurs esp. at transonic speeds; the noise resulting from this vibration.

aileron droop. The simultaneous downward, or positive, deflection or hang of the ailerons on both sides of an airplane so as to create additional overall lift.

aileron reversal. A reversal of the control effect usually produced by the deflection of an aileron in a given direction, e.g., the lowering, rather than the rising, of a wing when the attached aileron is deflected downward, caused by the aileron action twisting the wing and changing its angle of attack so that it overcomes the lifting effect of the downward aileron deflection. This condition arises at certain flight speeds with wings insufficiently stiff in torsion.

aileron reversal speed. The speed of a given airplane above which aileron reversal occurs.

aileron roll. Same as SLOW ROLL.

aileron yaw. Yaw caused by aileron movement.

ailerator, *noun*. [Aileron + elevator—a variant of "ailavator."] Same as ELEVON.

air, *noun*. 1. The gaseous substance surrounding the earth, being principally a mixture of gases (although often considered a single gas), and consisting mainly of nitrogen and oxygen, in the ratio of about four parts of the former to one of the latter, but containing also varying amounts of water vapor, and relatively small quantities of the gases argon, carbon dioxide, hydrogen, neon, helium, krypton, and xenon. Particles of dust and smoke, bacteria, spores, etc. suspended in the air are not usually considered a part of it. Air extends upward with decreasing density from the surface of the earth, having a normal pressure of about 14.7 pounds per square inch at sea level. Air is both compressible and elastic, and its principal importance in aeronautics is its character as a fluid, thus affording a medium or means of support for aircraft. 2. Any particular portion of this substance, distinguished by some special quality, character, or treatment from the surrounding air, as, *air* that migrates from the polar regions, or, a leakage of *air* from a cylinder. 3. A gas—in this sense esp. in some combinations and attributive uses: see AIR-OIL SHOCK STRUT. 4. a. The air (in sense 1) regarded as the realm or medium in which aircraft

travel or operate. b. This air conceived of as a medium for commerce, warfare, etc. by the use of aircraft—disting. from the land and sea, as, transport by *air*, or, the conquest of the *air*. 5. A military force or service that operates in the air (sense 1), or military force or power exerted in or from the air (*air power*), as, the defeat of the enemy *air*, or, the coordination of land, sea, and *air*.

air base. 1. a. A base of operations for military or naval aircraft. b. A military airdrome, including all associated installations or facilities, such as barracks, drill grounds, stores, clubs, warehouses, garages, hospital, etc. 2. *Aerial Photography*. An imaginary line connecting the points at flight altitude at which successive photographs in a strip are taken; the length of this line.

air bends. The full, though seldom-used, term for "bends" (which see) caused by change from a high to a low atmospheric pressure.

air bleed. 1. A drawing off or tapping of air from a source, as from an air compressor; the air drawn off. 2. An apparatus or device for tapping air.

air blower. A fan or pump for blowing or compressing air; *specif.*, such a fan or pump for inflating a balloon, gasbag, or airship for inspection and repair.

airborne, *adj.* 1. a. Of a heavier-than-air aircraft: Entirely supported by aerodynamic forces, as, the airplane became *airborne* at seventy-five miles an hour. b. Of an airship or free balloon: Unmoored and floating in the air. c. Of a captive balloon: Aloft. 2. Of persons: Borne in the air by aircraft, as, we were *airborne* for two hours. 3. Carried by air or by aircraft; *specif.*: a. Of equipment: Intended to be carried by, or installed in, aircraft, as in *airborne* radar. b. Of persons, esp. of troops: Organized, trained, and equipped to be transported to the scene of battle or other action by aircraft. 4. Made or done by airborne (sense 3b) persons or troops carried in aircraft, as in *airborne* attack.

air box. A metal box or chamber in which carburetors are tested and adjusted for metering characteristics by pumping or flowing air through them. The carburetors are operated without burning the fuel-air mixture in an engine, a pump or blower providing the

suction normally furnished by the engine.

air brake. 1. Any device that utilizes aerodynamic reactions to slow down an aircraft, esp. a flap, spoiler, plate, or the like that slows down an aircraft by increasing its aerodynamic drag. See DECELERATION PARACHUTE, DIVE BRAKE, LANDING BRAKE, SPEED BRAKE. 2. A wheel brake operated by compressed air.

air-breathing, *adj.* Of an engine: That takes in air for the purpose of combustion.

air bump. A local air disturbance, i. e., a current or turbulent place in the air, which causes a jerk or sudden acceleration of an aircraft when it flies into it. Usually called a "bump." Cf. AIR POCKET.

air carrier. 1. A person or organization that carries freight or people by aircraft for hire. 2. An aircraft that carries cargo or passengers. 3. A CARRIER AIRCRAFT (in sense 2).

air chamber. A chamber that holds air; specif., a chamber between the air scoops and blower and the valves leading to the ballonets in a nonrigid airship.

air-cool, *verb tr.* To cool by air, as a bearing, a cylinder, an engine, etc.

—air-cooled, *adj.*

aircraft, *noun.* Any structure, machine, or contrivance, esp. a vehicle, designed to be supported by the air, being borne up either by the dynamic action of the air upon the surfaces of the structure or object, or by its own buoyancy; such structures, machines, or vehicles collectively, as, fifty *aircraft*.

"Aircraft," in its broadest meaning, includes fixed-wing airplanes, helicopters, gliders, airships, free and captive balloons, ornithopters, flying model aircraft, kites, etc., but since the term carries a strong vehicular suggestion, it is more often applied, or recognized to apply, only to such of these craft as are designed to support or convey a burden in or through the air.

Guided missiles, flying bombs, etc., that are supported by the air, such as the German V-1 of WW II, are aircraft, while guided missiles, flying vehicles, or projectiles that are not supported by the air, such as the Viking rocket, are rarely, if ever, considered aircraft. However, in the absence of any widely accepted general term to embrace all kinds of flying vehicles, "aircraft" is sometimes employed *generically* in this sense; but this usage is uncertain and is not sanctioned by common acceptance. See PILOTLESS AIRCRAFT and VEHICLE.

aircraft accessory. An accessory (which see) other than an engine accessory,

attached to, or used with, an aircraft, i. e., an accessory associated with the airframe, as distinct from the engine.

The category of aircraft accessories is generally taken to include lighting systems, de-icing systems, seats, canopies, safety belts, fire extinguishers, parachutes, life rafts, instruments, radio equipment, and, on airships, gas and air valves and nose stiffening.

aircraft carrier. 1. Broadly, a vessel, aircraft, or other vehicle designed specially to carry aircraft. 2. Specif., a ship especially designed to carry fixed-wing airplanes, and having a special deck and gear to permit their take-off and landing.

aircraft dope. Dope (in sense 1, which see) for application to the fabric surfaces of aircraft.

aircraft engine. An engine (which see, and note) designed or used to propel aircraft. Such an engine is characterized by a relatively low weight for the power produced.

aircraft engine mechanic. A person trained in the maintenance and repair of aircraft engines. Cf. AIRCRAFT MECHANIC.

aircraft instrument. Any instrument (which see) used or designed to be used on aircraft; specif., any such instrument other than an engine instrument.

See ENGINE INSTRUMENT, FLIGHT INSTRUMENT, NAVIGATION INSTRUMENT.

aircraft mechanic. A person trained in the maintenance and repair of aircraft; spec., such a person primarily concerned with aircraft structures, fittings, systems, and components other than engines and their accessories and associated systems—disting. in this specific sense from an AIRCRAFT ENGINE MECHANIC.

aircraft rocket. A rocket missile designed to be carried by, and launched from, an aircraft.

aircrew, *noun.* The team, company, or group of persons who man an aircraft. Also called a "flight crew." In military contexts, the term is applied also to the pilot of a single-place aircraft.

air current. A current or flow of air; specif., *Meteorol.*, a rising or descending current of air. See CONVECTION CURRENT.

air damper valve. On an airship, a valve that controls the amount of air forced into a ballonet. Cf. AIR VALVE.

air drag. Same as AERODYNAMIC DRAG.

airdrome, *noun.* 1. An area of land or water, together with any buildings, installations, or facilities, used for the take-off and landing of aircraft, particularly of airplanes. "Airdrome" is applied to any airport or airfield, either civil or military, usually without any import as to size, extent of facilities, etc. "Seaplane base" is the usual term for a water airdrome. 2. More restrictively, that part of an airfield, air base, or airport comprised principally of the take-off and landing area, taxiways, and hangars. Used in this sense esp. in military contexts. See AIRFIELD, sense 2.

air duct. Any duct for the passage of air, such as a passage that leads air to the intake of a gas-turbine engine.

air exchanger. A device that draws off heated air moving in a wind tunnel and replaces it with cooler outside air.

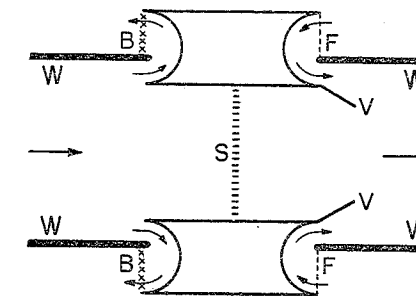

Air exchanger (simplified). (Arrows show direction of flow.) W tunnel walls; B noise baffles and screens; F filter screens; V flow control vanes; S screen providing pressure drop.

airfield, *noun.* 1. An airport on land; specif., an airport on land having limited or no provision for the shelter, service, or repair of aircraft. See FLYING FIELD, INTERMEDIATE FIELD. 2. More restrictively, that part of a land-established airport comprising the take-off and landing area.

airflow, *noun.* A flow or stream of air. An airflow may take place in a wind tunnel, in the induction system of an engine, etc., or a relative airflow can occur, as past the wing or other parts of a moving airplane; a rate of flow, measured by mass or volume per unit of time. See FLOW.

airfoil, *noun.* 1. A structure, piece, or body, originally likened to a foil or leaf

in being wide and thin, designed to obtain a useful reaction upon itself in its motion through the air. An airfoil may be no more than a flat plate, but usually it has a cross section carefully contoured in accordance with its intended application or function. Airfoils are applied to aircraft, missiles, or other aerial vehicles or projectiles for sustentation (as a wing); for stability (as a fin); for control (as an elevator); and for thrust or propulsion (as a propeller blade). Certain airfoils combine some of these functions. See AUXILIARY AIRFOIL. 2. Hence, any such structure or body as a member of an aircraft, missile, or the like, i. e., a wing, rudder, fin, rotor blade, etc. See SURFACE, sense 2. 3. In aerodynamic theory and experiment: a. Such a body as described in sense 1 considered or treated as an independent object, i. e., without reference to the aircraft or other body to which it is applicable, and also without regard to structure—disting. in this sense from a wing, fin, blade, etc.

"Another important difference between the shape of an *airfoil* and an actual wing is introduced by the necessity of providing smooth transitions between the wing surface and such interruptions as the fuselage or engine nacelles." Richard von Mises, *Theory of Flight*.

b. An airfoil section or profile.

"The types of *airfoils* used at various stations along the propeller blade also play an important part in determining propeller efficiency." Daniel G. Dommasch, *Elements of Propeller and Helicopter Aerodynamics*. See BICONVEX AIRFOIL, CIRCULAR-ARC AIRFOIL, CLARK Y AIRFOIL, DOUBLE-WEDGE AIRFOIL.

An airfoil is akin to a vane in its operation, but the two are not commonly identified, the distinction arising chiefly from the different purposes to which each is applied. Compare sense 1, above, with VANE, senses 2 and 3; also see VANE, sense 1b.

airfoil characteristic. 1. Technically, any aerodynamic quality peculiar to a particular airfoil, esp. to an airfoil section or profile, usually at a specified angle of attack. Airfoil characteristics are expressed variously as the coefficients of lift, drag, or pitching moment, the zero-lift angle, the lift-drag ratio, etc. 2. A feature of any particular airfoil or airfoil section, such as the actual or relative amount of span, taper, thickness, etc.

airfoil profile. The outline or form of an airfoil section. See AIRFOIL SECTION and note.

airfoil section. a. A section of an airfoil, esp. a cross section taken at right angles to the span axis or some other specified axis of the airfoil. b. In most usages, the form or shape of an airfoil section; an airfoil profile or the area defined by the profile.

Where the section or profile of a particular airfoil is under discussion, it is often specified as a "wing section," a "blade profile," etc.

air force. 1. A force effected by air (which see, senses 1 and 2), esp. a dynamic force produced by moving air, i. e., an aerodynamic force. See AIR PRESSURE, sense a. 2. A nation's military establishment or service that is organized, trained, and equipped for air warfare; a military or naval organization for air warfare or other air operations. Usually capitalized in reference to a specific service or organization. See AIR, sense 5.

airframe, noun. The structure of an aircraft, guided missile, or the like, apart from accessories and power plant. The principal parts of the airframe of an airplane include the fuselage, wings, empennage, landing gear, and nacelles or pods.

air-fuel ratio. The ratio, by weight, of air to fuel in a combustible mixture. (Mixture richness is more often expressed by use of the reciprocal term, "fuel-air ratio".)

airglow, noun. A glow or light of the upper atmosphere.

air-ground, adj. 1. Going from aircraft to the ground, or occurring between aircraft and the ground, as in *air-ground* communication; designed or designated for use between aircraft and the ground, as in *air-ground* radio. Cf. AIR-SURFACE. 2. Of or pertaining to both air and ground military forces, as in *air-ground* maneuvers.

air-injection starter. A type of starter for internal-combustion reciprocating engines that introduces compressed air into the cylinders of an engine in order to rotate it. Not in common use on aircraft engines.

air inlet. An entrance or orifice for the admission of air, as in a jet engine or jet aircraft. See AIR INTAKE.

air intake. An orifice for taking in air, as in the induction system of a reciprocating engine; an AIR SCOOP; an AIR INLET.

air lane. A route or way in the air, usually one provided with air-navigation aids and prescribed by proper authority.

air-launch, verb tr. To launch from an aircraft in the air, as, to *air-launch* a guided missile, an aerial target, an aircraft, etc.

airlift, noun. 1. The action of transporting persons or freight by air. 2. A transport or supply line using aircraft. **airlift, verb tr.** To transport by aircraft. **airline, noun.** a. An established air-transportation system, or the company that owns or operates such a system. b. The equipment or property owned by such an organization. c. A route regularly used by an air-transport organization.

air line. A tube, hose, or the like for conveying air.

airliner, noun. A large passenger aircraft designed or used for commercial airline service.

air load. An AERODYNAMIC LOAD.

air lock. 1. A stoppage or diminution of flow in a fuel system, hydraulic system, or the like, caused by a pocket of air or vapor. See VAPOR LOCK. 2. A chamber capable of being hermetically sealed that provides for passage between two places of different pressure, as between an altitude chamber and the outside atmosphere.

air log. A device employing an air-driven screw to measure distance traveled through the air, and used, e. g., on certain robot missiles.

airman, noun. 1. An aircraft pilot or other aircrew member; also, sometimes, an aircraft mechanic, aircraft dispatcher, or other person concerned with the operation or maintenance of aircraft. 2. a. Any enlisted person in the US Air Force. b. A title applied to enlisted persons of certain ranks in the US Air Force or Navy.

air marker. A mark or sign on the ground so made as to be visible to aircraft, indicating direction or giving other useful information.

Air markers, for example, may indicate the direction of true north, the direction and distance to the nearest airport, highway numbers, names of communities, etc.

air mass. 1. A body or mass of air. 2. *Meteorol.* A large body of air within which the conditions of temperature and humidity throughout any given level are approximately uniform.

In sense 2, an air mass takes its temperature and moisture characteristics from its source region; hence, words or letters designating the source region of an air mass serve to indicate its temperature and moisture characteristics, as in maritime polar (mP) air mass, continental tropical (cT) air mass, etc.

air navigation. The act or practice of navigating through the air; the art or science of navigation in the air. See NAVIGATION.

Air navigation, though using the fundamental methods and techniques of marine navigation, has special problems arising mainly from the different element in which aircraft operate, from the high speeds of aircraft, and from certain physical limitations associated with aircraft and their operation; certain methods and techniques used in air navigation, such as pressure-pattern flying, together with certain navigational aids and instruments, such as radio ranges, either are peculiar to air navigation or have no close parallels in marine practice.

air-navigation aid. Something that assists in air navigation—a very broad term applied to instruments, devices, methods, techniques, etc.

Air-navigation aids include instruments, such as sextants, artificial horizons, driftmeters, etc. (see NAVIGATION INSTRUMENT); computers; surface navigational facilities, such as radio ranges, radar and light beacons, course lights, etc.; charts; landmarks and air markers; and airborne radio-navigation equipment.

air-oil shock strut. A type of shock strut containing oil and compressed air or other gas, i. e., a pneumatic shock strut. See PNEUMATIC.

airpark, noun. 1. A small airfield where aircraft may be parked or kept; esp., a small airfield convenient to a downtown metropolitan area, a suburb, a resort area, etc., for the use of commuters, shoppers, or travelers, where aircraft may take off, land, and park—analogue to an automobile parking lot. 2. Any open area or place where aircraft are kept.

air pick-off. A kind of pick-off (which see) consisting of an air inlet or nozzle and a shut-off device, used for controlling the flow and pressures of air in a system.

airplane, noun. [See note on the derivation.] 1. Specif.: a. In most usages,

an engine-driven heavier-than-air aircraft that obtains lifting force from the dynamic action of air against fixed wings (see FIXED WING), as, aircraft types include the *airplane*, glider, and helicopter. b. More restrictively, an aircraft as described in sense 1a, above, designed to take off and alight with wheels on land or some other firm surface—disting. from a seaplane or flying boat, as, *airplanes* and *seaplanes* have certain structural differences. See LANDPLANE. 2. In a broad sense, a heavier-than-air aircraft, either powered or unpowered, that obtains sustentation from the dynamic action of air against airfoils, or "planes," that are either fixed or moving in relation to the aircraft as a whole, as, the glider is a type of *airplane* that lacks an engine, or, the autogiro is an unconventional kind of *airplane*; an aerodyne.

It is now generally recognized that the first completely successful, i. e., sustained and fully controlled, man-made flight in an engine-driven airplane took place on December 17, 1903, near Kitty Hawk, North Carolina, in a biplane designed and built by the brothers Wilbur and Orville Wright, the machine being piloted on this flight by Orville Wright. Previous to this, various power-driven model airplanes, some of which were quite large, had been constructed and flown with considerable success by John Stringfellow, Lawrence Hargrave, S. P. Langley, and other experimenters, using steam, compressed air, and other forms of power. A limited amount of success with a steam-powered, man-carrying airplane appears to have been achieved by Clement Ader in France in 1897. Alberto Santos-Dumont is credited with making the first successful public airplane flight in Europe, in 1906. Successful gliding flight, practically a prerequisite to successful powered heavier-than-air flight, was performed by J. M. Le Bris, Otto Lilienthal, Octave Chanute, John J. Montgomery, the Wright brothers, and others during the nineteenth century and previous to the powered Wright flight in the twentieth century.

Airplanes are often classified or distinguished by: a. Number of engines, as *four-engine(d)*, *multiengine(d)* or *single-engine(d) airplane*. b. The kind of engine or engines used, as *jet*, *piston-engine(d)*, or *rocket airplane*. c. Placement of propellers, as *pusher* and *tractor airplane*. d. Number of places, i. e., number of persons the airplane seats or carries, as *single-place* or *two-place airplane* (not used for most large modern airplanes). e. Purpose or employment, as *agricultural*, *fighter*, or *transport airplane*; *commercial* or *military airplane*. f. Configuration, some outstanding capability or feature, etc., as *canard*, *high-speed*, *swept-wing*, or *tailless airplane* (in occasional distinctions rather than in formal classifications). [The following in combinations, using *plane*; see PLANE, noun.] g. The surface from which the airplane operates, as *landplane* or *seaplane*. h. The number of supporting structures, as *biplane*, *multiplane*, or *triplane*.

airplane dope. Dope (in sense 1, which see) for application to the fabric surfaces of airplanes.

airplane trim. The trim (which see, sense 1) of an airplane with respect to the airstream.

air plot. 1. A geographic plot showing the movements and positions of an aircraft as if it were flying through motionless air. The direction of true heading is plotted as track, and true airspeed is plotted as ground speed. 2. The action of making such a plot.

air pocket. 1. A place in the air where conditions are such as to cause an aircraft to drop, rise, or swerve; esp., a downward stream of air that causes an aircraft to drop, as if into a pocket. Cf. AIR BUMP. 2. A bubble of air or an air-filled section in a pipe or line containing liquid, as in a hydraulic line.

airport, noun. An airdrome; specif., an airdrome regularly used for the take-off and landing of aircraft and for receiving and discharging passengers and cargo, and usually having somewhat extensive facilities for servicing, repairing, and sheltering aircraft.

In most usages, "airport" is applied in its general meaning, i. e., to any place for the take-off and landing of aircraft, without any signification as to size, extent of facilities, etc. In this sense the word is closely synonymous with "airdrome" (in sense 1).

Although the application of "airport" is not specifically restricted to civil airdromes, the word is used most often in nonmilitary contexts, and is not applied to particular military or naval airfields.

airport beacon. A rotating beacon located at or near an airport to indicate the specific or general location of the airport.

airport of entry. An airport including customs facilities, etc., through which air traffic is cleared to or from another country.

airport surveillance radar. Radar equipment or a radar system used in air traffic control, which scans the airspace for a distance of approximately thirty to sixty miles around an airport and which shows, on an indicator in the airport control tower, the location of all airborne aircraft below a certain altitude and obstructions to flight within its range. Used in conjunction with precision approach radar. See PRECISION APPROACH RADAR.

air position. The position an aircraft would have if flying in motionless air, i. e., if the flight had been unaffected by wind. Also called a "no-wind position."

air-position indicator. A flight instrument that automatically and continuously calculates and indicates the air position of an aircraft.

air pressure. a. The pressure or force exerted by either still or moving air, esp. still air; the amount of this force, commonly indicated in units of weight per unit of area. See AIR FORCE, sense 1. b. Atmospheric pressure.

air propeller. A propeller that works in air—disting. from a marine propeller. Commonly called a "propeller" in aeronautical contexts.

air refueling. The action of resupplying an aircraft with fuel in the air, conveying it from one aircraft to the other by means of hoses and other special equipment. Also called "flight refueling" or "in-flight refueling."

air relay. A device in a pneumatic system, analogous to an electrical relay, operated by variations in air pressure, and which, in its turn, operates another device, as a valve.

air resistance. The resistance or opposition offered by the air to the motion of an aircraft, missile, or other body through it. See DRAG.

air route. A route or established way in the air connecting airports, regularly traveled by aircraft and usually provided with air-navigation aids and governed by flight rules.

air scoop. A scooplike structure, hood, or open end of an air duct projecting into, or presented to, the airstream about an aircraft in such a way as to capture air to be conducted to an engine, a ventilator, etc.

airscrew, noun. 1. A screw that works in the air—disting. from a marine screw. 2. AN AIR PROPELLER. *Chiefly British.*

This term at present is generally regarded as a Britishism, i. e., in sense 2. A need has arisen, however, for a descriptive term for devices that are similar to propellers but that do not propel or whose primary function is something other than to propel; "airscrew" fills this need and lately has come to be so applied to a limited extent. See ANTI-TORQUE ROTOR and SCREW.

airship, noun. A self-propelled and dirigible lighter-than-air aircraft. Airships are classified as *nonrigid*, *rigid*, *semirigid*, and, sometimes, *pressure-rigid*. (See individual entries on these

types; also see PRESSURE AIRSHIP.) These classifications are now chiefly historical. Cf. SHIP, sense 1.

Airship flight antedated airplane flight, fairly successful experiments, under more or less ideal conditions, being made in France in powered aerostats by, among others, Henri Giffard, using a steam-powered elongated balloon, in 1852; Albert and Gaston Tissandier, using an electric power plant, during 1883-84; and Charles Renard and A. C. Krebs, also using electrical power, during 1884-85. In 1901, Alberto Santos-Dumont, piloting an airship powered by an internal-combustion engine, won a prize for making a seven-mile flight, circling the Eiffel Tower, in about thirty minutes. In Germany, Count von Zeppelin launched the first of his rigid airships in 1900. Following is a brief chronology of some of the important events in airship history:

1917—German Zeppelin, the *L-59*, voyaged on military mission nonstop from Bulgaria to Khartoum, Africa, and return, traveling a distance of some 4,000 miles.

1919—British rigid airship, the *R-34*, made round-trip transatlantic flight.

1923—US Navy airship *Shenandoah* launched; first American-built rigid.

1924—German-built Zeppelin, the *ZR-8*, delivered to US in reparations, rechristened the *Los Angeles*. Retired from service in 1932, having flown some 200,000 miles.

1925—*Shenandoah* destroyed in a storm.

1928—German commercial ship *Graf Zeppelin* launched. In service until laid up in 1937, flying 1,053,391 miles, and making round-the-world flight.

1931—US Navy rigid airship *Akron* commissioned.

1933—*Akron* crashed at sea; sister ship, *Macon*, commissioned. Both craft used as airplane carriers.

1935—*Macon* failed structurally and sunk in Pacific.

1937—German airship *Hindenburg* burned at Lakehurst, New Jersey.

1957—US Navy nonrigid airship *Snowbird* established new distance and endurance records, remaining in air over 264 hours and traveling over 8,000 miles without refueling.

Today the aeronautical field is almost entirely dominated by heavier-than-air aircraft, with the only important airship activity in the world being conducted by the US Navy, which maintains and operates a fleet of nonrigids for various special purposes, such as radar early warning and antisubmarine warfare.

airship hangar. A hangar (which see) for housing airships. Also called a "dock" or "airship shed."

airship hull. The main body of an airship, i. e., the fabric-covered framework of a rigid airship, or the envelope of a nonrigid or other type airship.

airship pilot. A person who flies, or is trained to fly, an airship; on certain airships, the person who operates the elevator controls. Cf. COPILOT, sense 2.

airship shed. Same as AIRSHIP HANGAR.

airship station. A place or base from which airships operate, comprising grounds, hangars, mooring masts, gas

storage houses, and other facilities or installations.

air sounding. The act of measuring atmospheric phenomena or determining atmospheric conditions at altitude, esp. by means of apparatus carried by balloons or rockets.

airspace, noun. Space in the air above the surface of the earth, or a particular portion of such space, usually defined by the boundaries of an area on the surface, projected upward.

Airspace is sometimes particularized by altitude, as the *airspace* above 20,000 feet. See NAVIGABLE AIRSPACE.

airspeed, noun. 1. a. The speed of anything relative to the surrounding air; esp., the speed of an aircraft relative to the air through which it flies. Cf. GROUND SPEED. b. The speed of an aircraft, rocket vehicle, or the like relative to the air through which it flies as shown by an indicated measurement or derived value revealing airspeed (in sense 1a) under certain assumed conditions—or with certain contributory effects neglected—or such a measurement or value revealing in itself, more or less accurately, the actual speed of an aircraft or other vehicle relative to the surrounding air.

In most usages, the unqualified term "airspeed" is employed in sense 1a, and where no particular speed is specified, as in "The airplane can land at a low *airspeed*." Sense 1b defines the word esp. as it is used in the terms *basic airspeed*, *calibrated airspeed*, *equivalent airspeed*, *indicated airspeed*, and *true airspeed*. (See individual entries.) When the word is used in sense 1b, careful qualification is necessary to avoid ambiguity.

2. *Commonly written air speed.* The speed of air, as, the fans provide an *air speed* of 500 mph in the tunnel.

airspeed bomb. A pitot-static tube or head trailed below an aircraft and used in airspeed calibrations. The airspeed bomb is attached by tubing to a test indicator in the aircraft, the entire apparatus being used to check the accuracy of the installed airspeed indicator. The airspeed bomb is used to obtain pressure measurements in a region little influenced by the aircraft.

airspeed head. A device that projects into an airstream to obtain pressures transmitted to an airspeed indicator. It is commonly a pitot-static head or tube.

airspeed indicator. Any instrument or meter designed to indicate airspeed; commonly, an instrument designed

either to show measurements of airspeed related to assumed air conditions, or to show airspeed measurements automatically corrected for certain existing air conditions. Sometimes called an airspeed meter.

In its simplest form, the airspeed indicator incorporates a single metallic capsule—a hollow disk of thin metal—that is expanded by pitot pressure received inside the capsule, the expansion being opposed by the static air pressure surrounding the capsule; the expansion and contraction of the capsule are utilized to actuate a pointer on a dial graduated in units of airspeed. This form of airspeed indicator is designed to show an approximately true value of airspeed under standard sea-level conditions. Therefore, it is necessary to apply various corrections to the reading of the instrument to find an airspeed value approximating the true, or actual, airspeed. See TRUE AIRSPEED INDICATOR.

air start. An act or instance of starting an aircraft's engine, esp. a jet engine after flameout, in the air. An air start is ordinarily accomplished by windmilling the engine and not by using the aircraft's starting system.

air station. A US naval station where aircraft are based, and from which they operate. The station may be for either a lighter-than-air or heavier-than-air aircraft.

airstream, noun. A stream of air, as in a wind tunnel or past a moving airplane; an airflow.

airstream engine. A reaction engine that takes in air chiefly to support combustion. *Rare.* See JET ENGINE, sense 2.

airstrip, noun. A cleared strip of land, usually hard-surfaced, for the take-off and landing of airplanes, often established in advanced military positions or in out-of-the-way places for emergency or occasional use.

Commonly, airstrips have few or no facilities for the care of airplanes, although fuel and other supplies are often on hand.

air-surface, adj. Same as AIR-TO-SURFACE.

air temperature. The temperature of the air; specif., the temperature of the air about a flying aircraft. See FREE-AIR TEMPERATURE.

—air-temperature gauge, air-temperature indicator.

air terminal. An airport where flights regularly terminate (and originate), having facilities for handling freight, passengers, etc.

air-to-air, adj. Occurring or going between one place and another in the air,

or between aircraft, as in *air-to-air* communication, *air-to-air* gunnery; designed or designated for use between aircraft, as in *air-to-air* guided missile.

air-to-ground, adj. Same as AIR-GROUND (in sense 1).

air-to-surface, adj. Between aircraft and the surface of the earth; occurring or going between the air and the surface of the earth, as in *air-to-surface* communication; designed or designated for use between the air and the surface, as in *air-to-surface* missile.

air traffic. 1. Aircraft in operation or movement in the air or on the surface in those surface areas normally used for the movement of aircraft; the movement of these aircraft. 2. The passengers or cargo carried by aircraft.

air traffic clearance. An authorization for an aircraft to fly in an airspace within which air traffic control is exercised, under specified conditions which will prevent collision with other known aircraft within the airspace.

air traffic control. The control of air traffic to maintain its safe, orderly, and expeditious movement; [*Usually capitalized.*] a service or organization providing this control.

—air traffic controller.

air valve. A valve controlling the flow of air; specif., on an airship, a relief valve for controlling air pressure in a ballonet. Cf. AIR DAMPER VALVE.

air vane. A vane that acts in the air—disting. from a JET VANE.

air vehicle. A vehicle designed to carry a burden through air—a conceptual term for "aircraft." See VEHICLE and note.

air volume. Specif., the volume of the air displaced by an aerostat.

The air volume, for airships especially, is considered to be the volume displaced by the complete aircraft, including all appendages or protuberances, such as cars, tail surfaces, etc. Cf. GAS VOLUME.

airway, noun. A designated air route between points on the earth's surface; specif., a civil airway. See AIR ROUTE, CIVIL AIRWAY.

airway beacon. A rotating beacon located on or near an airway, other than an airport beacon or landmark beacon, serving to indicate the location of the airway. The beacon is usually provided with course lights.

air wheel. An aircraft landing-gear wheel consisting of a small hub with a fat, balloon-type, low-pressure tire.

air work. Activity in the air; flying practice; that part of a flying training course in which actual flight is performed.

airworthiness, noun. The state or quality of an aircraft or of an aircraft component or accessory being fitted safely to perform or be used within the limitations imposed by its intended purpose or use; esp., this state or quality as certified by proper authority.

—airworthy, adj.

Alfaro flap. [After Heraclo Alfaro (1885–), Spanish engineer.] A type of flap whose hinge axis moves rearward as the flap is deflected, the trailing edge moving in a shallow arc. Cf. ZAP FLAP.

alight, verb intr. 1. To come down to the ground; to land—sometimes used to avoid an unpleasing repetition, as, to *alight* on land (rather than to *land* on land). 2. To get down or descend, as from an aircraft, as, he landed, and *alighted* from the airplane.

alighting gear. Same as LANDING GEAR (in senses 1 or 2).

all-burnt, noun. The time at which a rocket consumes its propellants. Chiefly British. Cf. BRENNSCHLUSS, BURNOUT, sense 1.

all-movable tail. A horizontal or vertical tail surface that pivots as a whole, as distinct from the usual combination of fixed and movable surfaces. Also called a "slab tail." See STABILATOR.

allowable load. The maximum load permissible on a structural member or part under given conditions.

all-weather, adj. 1. a. Designed or equipped to perform by day or night under any weather conditions, as in *all-weather* fighter. b. Equipped with aircraft that are all-weather (in sense 1a), as in *all-weather* squadron. 2. That takes place under any conditions of weather or visibility, as in *all-weather* flight. 3. Of aircraft components, equipment, etc.: Designed or intended to effect, or to be used in, all-weather flight, as in *all-weather* instruments.

alpha hinge. A designation for the drag hinge of an articulated rotor blade. See ARTICULATED ROTOR (illus.), DRAG HINGE.

alternate airport. An airport at which a landing is, or may be, made if a landing at the intended airport is inadvisable or impossible.

altigraph, noun. A recording altimeter.

altimeter, noun. Any of various types of instruments for measuring altitude; specif., an instrument similar to an aneroid barometer that utilizes the change of atmospheric pressure with altitude to indicate the approximate elevation above a given point or plane used as a reference.

See ABSOLUTE ALTIMETER, CAPACITANCE ALTIMETER, PRESSURE ALTIMETER, RADIO ALTIMETER, SENSITIVE ALTIMETER, SONIC ALTIMETER, STATOSCOPE.

altimeter setting. A pressure valve used for setting a pressure altimeter so that upon landing of the aircraft at an airport the instrument will indicate an altitude equal to or very close to the field elevation above sea level.

altitude, noun. 1. Height, esp. height as measured above a given datum plane or above a point, as above average sea level or above a point on the terrain; a station, position, or region at height, as, to maintain *altitude*, or, to climb to *altitude*.

See ABSOLUTE ALTITUDE, CALIBRATED ALTITUDE, CRITICAL ALTITUDE, DENSITY ALTITUDE, INDICATED ALTITUDE, PRESSURE ALTITUDE, TRUE ALTITUDE.

2. The capability of an aircraft, aircraft engine, or other aircraft component to perform efficiently at a given altitude, as, the plane has the required speed and *altitude*. 3. An air pressure simulating the pressure at a given altitude. See CABIN ALTITUDE, PRESSURE ALTITUDE, sense 2. 4. *Nav.* ANGULAR ALTITUDE.

altitude chamber. A chamber within which the air pressure, temperature, etc., can be adjusted to simulate conditions at different altitudes, used for experimentation, testing, etc. See DECOMPRESSION CHAMBER.

altitude compensation. The action of compensating for an effect brought on by a change in altitude, such as the action of certain devices in a carburetion system to overcome a tendency for mixture enrichment brought on by an increase in altitude. See ALTITUDE MIXTURE CONTROL.

altitude engine. A reciprocating aircraft engine with a high degree of supercharging, intended esp. for use at relatively high altitudes. Cf. SEA-LEVEL ENGINE, SUPERCHARGED ENGINE.

altitude mixture control. A carburetor device, now usually automatically operated, that maintains a desired fuel-air mixture ratio supplied to an engine at different altitudes. See AUTOMATIC MIXTURE CONTROL and cf. BAROMETRIC FUEL CONTROL.

altitude sickness. Sickness, such as aeroembolism, brought on by ascent to high altitudes, or sickness brought on by the expansion of gas or air in the body owing to reduced external pressure at altitude.

altitude wind tunnel. A wind tunnel in which the air pressure, temperature, and humidity can be varied to simulate conditions at different altitudes. In an altitude wind tunnel for testing engines, provision is made for exchanging fresh air for exhaust-laden air during operation.

ambient, adj. Surrounding; specif., of or pertaining to the air or air conditions about a flying aircraft or other body but undisturbed or unaffected by it, as in *ambient air*, *ambient temperature*.

ambiguity, noun. *Air nav.* The condition existing when a radio bearing is obtained, as with a manually-operated radio compass, that does not indicate whether or not an aircraft is flying toward or away from a radio-transmitting station. Sometimes called specifically "180-degree ambiguity." See AUTOMATIC DIRECTION FINDER.

amidships, adv. At, near, or toward the middle of a ship, aircraft, etc.

amphibian, noun. A fixed-wing or rotary-wing aircraft designed or equipped to take off from and alight on both land and water.

amphibian, adj. a. Of aircraft, aircraft components, etc.: Designed or adapted for both land and water, as in *amphibian flying boat*, *amphibian gear*. See AMPHIBIAN, *noun*. b. Of a flying organization: Equipped with amphibian aircraft, as in *amphibian squadron*.

"Amphibian" is mostly used as an attributive adjective. See AMPHIBIOUS, *note*.

amphibious, adj. Of an aircraft, flying organization, etc.: Same as AMPHIBIAN.

"Amphibious" is used either as an attributive or predicative adjective. See AMPHIBIAN, *adj.*, *note*.

amplifier, noun. A device or system that amplifies an electrical current, a force, etc.; esp., an electrical device, usually including a vacuum tube or tubes, that amplifies an electrical current or signal.

anchor light. A light on a seaplane used to show its position at night, when riding at anchor.

anemometer, noun. An instrument for measuring the speed of the wind.

Anemometers are made in several forms; these include, but are not limited to, the cup anemometer, which measures wind speed in proportion to the rotation of a shaft turned by a wheel having hemispherical cups that catch the wind; the vane anemometer, which utilizes a vane or plate deflected past a scale by the wind; and the windmill-type anemometer, which utilizes a wind-driven screw; see HOT-WIRE ANEMOMETER. All these types have been experimented with or used at one time or another for air-speed measurements on aircraft.

aneroid, noun. [From *aneroid* barometer; see ANEROID, *adj.*] A thin, disk-shaped box or capsule, usually metallic, partially evacuated of air and sealed, which expands and contracts with changes in atmospheric or gaseous pressure. The aneroid is the sensing and actuating element in various meters or gauges, such as barometers, altimeters, manifold-pressure gauges, etc.; it is also the triggering or operating element in various automatic mechanisms.

A device similar to an aneroid, but non-evacuated and open to outside pressures, such as the capsule in an airspeed indicator, is not commonly called an "aneroid."

aneroid, adj. [Literally, "not wet"; originally applied to a kind of barometer.] 1. Not using a liquid substance as the sensing element—said of a barometer or altimeter using an evacuated capsule (see ANEROID, *noun*), rather than mercury or other liquid substance, as the sensing element. 2. Of or pertaining to the use of an evacuated capsule responding to changes in pressure, as in *aneroid principle*; using or incorporating this pressure-sensitive capsule (i. e., an "aneroid"), as in *aneroid mechanism*, *aneroid valve*. 3. Of a pressure-sensitive element: That is of the kind used in an aneroid barometer, as in *aneroid capsule*, *aneroid cell*.

angle, noun. 1. The inclination to one another of two lines or planes, or the inclination to one another of a line and its projection on a plane; a figure thus

formed; the amount or magnitude of this inclination, expressed in degrees or radians. 2. As mathematically defined, a measure, expressed in degrees or radians, of the amount of turning required to bring one side of an angle into coincidence with, or parallel to, another. An angle is measured by an arc limited by the sides of the angle, the arc being a part of a circle whose center is coincident with the point where the sides, or the extended sides, of the angle intersect.

See AILERON ANGLE, AZIMUTH ANGLE, BLADE ANGLE, CONING ANGLE, DECALAGE, DIHEDRAL ANGLE, DIVING ANGLE, DOWNWASH ANGLE, DRIFT ANGLE, ELEVATOR ANGLE, FLAP ANGLE, FLAPPING ANGLE, FLIGHT-PATH ANGLE, FREE-FLIGHT ANGLE, GLIDING ANGLE, HELIX ANGLE, INFLOW ANGLE, LAG ANGLE, LANDING ANGLE, LAUNCHING ANGLE, LEADING-EDGE ANGLE, MACH ANGLE, RUDDER ANGLE, SIDEWASH ANGLE, TAB ANGLE, TRAILING-EDGE ANGLE, TRIM ANGLE, UPWASH ANGLE.

angle of. Note on phrases beginning with "angle of":

It is to be understood that certain of these phrases, esp. some of the three-element phrases (e. g., "angle of bank," "angle of sideslip," etc.), also occur in compounds with "angle" as the final element (i. e., "bank angle," "sideslip angle," etc.). As pointed out in the Preface to this dictionary, the preferred term is that one under which the definition is given, and with these terms, as usual, the preferred term is that one which the evidence indicated writers employ more often. Where the evidence was fairly evenly divided, giving a choice between two terms, the shorter one was chosen as the preferred one.

angle of attack. 1. The angle at which a body, such as an airfoil or fuselage, or a system of bodies, such as a helicopter rotor, meets a flow, ordinarily measured between a reference line in the body and a line in the direction of the flow or in the direction of movement of the body. 2. Specif., the GEOMETRIC ANGLE OF ATTACK.

See ABSOLUTE ANGLE OF ATTACK, ANGLE OF MAXIMUM LIFT, CRITICAL ANGLE OF ATTACK, EFFECTIVE ANGLE OF ATTACK, IDEAL ANGLE OF ATTACK, INDUCED ANGLE, ROTOR ANGLE OF ATTACK, STALLING ANGLE, ZERO ANGLE OF ATTACK, ZERO-LIFT ANGLE OF ATTACK.

angle of attack for infinite aspect ratio. The angle of attack at which an airfoil produces any given lift coefficient in two-dimensional flow. See EFFECTIVE ANGLE OF ATTACK and *note*.

angle of attack for zero lift. Same as ZERO-LIFT ANGLE OF ATTACK.

angle of bank. The angle of roll of an aircraft, esp. in making a turn. See ANGLE OF ROLL.

angle of climb. The angle between a horizontal plane and the flight path of a climbing aircraft.

angle of crab. The horizontal angle between the longitudinal axis of a crabbed aircraft and its line of flight; a DRIFT ANGLE.

angle of dead rise. The acute angle with the horizontal made by a line joining the keel with the chine of a seaplane float or hull.

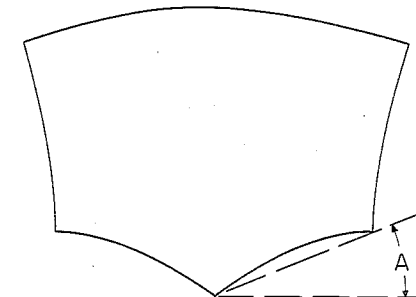

Angle of dead rise.

angle of dive. Same as DIVING ANGLE.

angle of downwash. Same as DOWNWASH ANGLE.

angle of drift. Same as DRIFT ANGLE.

angle of elevation. The acute angle between a horizontal plane and a line from an observer to an elevated object.

angle of fin setting. The ANGLE OF INCIDENCE (in sense 1) of a fin, esp. a vertical fin. For a vertical fin, the angle is positive when the leading edge is to starboard. Cf. ANGLE OF STABILIZER SETTING.

angle of glide. Same as GLIDING ANGLE.

angle of heel. The acute angle between a horizontal plane and the lateral axis of a floating seaplane.

angle of incidence. 1. The acute angle between a chord of an airfoil (usually the geometric chord) and the longitudinal axis of an aircraft, measured in a plane parallel to the plane of symmetry for horizontal airfoils and measured in a horizontal plane for vertical airfoils. This angle is measured with respect to fixed or adjustable airfoils, i. e., wings, fins, and stabilizers. With twisted airfoils, the root chord is commonly chosen to measure the angle of incidence. See ANGLE OF FIN SETTING, ANGLE OF STABILIZER SETTING, ANGLE OF WING SETTING. 2. Same as ANGLE OF ATTACK. *Chiefly British.*

angle of maximum lift. The angle of attack of an airfoil or airfoil section or other dynamically lifting body at which its lift is at a maximum, i. e., an angle of attack which, if increased, will produce a stall—often identified with the **STALLING ANGLE**.

angle of pitch. 1. The angle, as seen from the side, between the longitudinal body axis of an aircraft or similar body and a chosen reference line or plane, usually the horizontal plane. This angle is positive when the forward part of the longitudinal axis is directed above the reference line. 2. Same as **BLADE ANGLE** (in all senses).

angle of rake. Of a wing tip: The angle between the straight portion of a wing tip (in planform) and the plane of symmetry of an airplane. This angle is positive when the slant of the wing tip is toward the airplane's nose.

angle of roll. The angle that the lateral axis of an aircraft or similar body makes with a chosen reference plane in rolling; usually, the angle between the lateral axis and a horizontal plane. The angle of roll is considered positive if the roll is to starboard.

angle of sideslip. The angle, as seen from above, between the longitudinal body axis of an aircraft or similar body and the direction of the undisturbed airflow past the body. This angle is positive when the forward part of the longitudinal axis is directed to port. See **ANGLE OF YAW** and note.

angle of stabilizer setting. The **ANGLE OF INCIDENCE** (in sense 1) of a stabilizer, esp. a horizontal stabilizer. For a horizontal stabilizer, the angle is positive when the leading edge is higher than the trailing edge. Cf. **ANGLE OF FIN SETTING**.

angle of sweep. The acute angle between a reference line in a swept or tapered airfoil and some other chosen reference line or plane. For fixed airfoils, the angle is measured from a plane perpendicular to the longitudinal axis of the aircraft to the reference line of the airfoil, frequently the mean chord line. The angle is positive if the outboard end of the airfoil reference line is aft of the inboard end. For swept propeller or rotor blades, the angle is measured from the reference line of the airfoil to another convenient reference. For a swept rotor blade, e. g., the angle

may be measured between the reference line of the blade and a radius passing through a point in the blade reference line at which the sweep is being measured, the angle being positive when the blade reference line, outboard of this point, lies behind the radius with respect to the direction of rotation.

angle of trim. Same as **TRIM ANGLE**.

angle of wing setting. The **ANGLE OF INCIDENCE** (in sense 1) of a wing. This angle is positive when the leading edge of the wing is higher than the trailing edge.

angle of yaw. The angle, as seen from above, between the longitudinal body axis of an aircraft, rocket, or the like and a chosen reference direction. This angle is positive when the forward part of the longitudinal axis is directed to starboard.

The reference direction for measuring the angle of yaw may sometimes be the direction of the airflow past the body, making the angle of yaw equal to the angle of sideslip, though opposite in sign; under some conditions, however, as in turning, another reference direction may be used.

angle of zero lift. Same as **ZERO-LIFT ANGLE OF ATTACK**.

angular acceleration. The time rate of change of angular velocity.

angular altitude. *Nav.* The angular distance of a heavenly body above the horizon.

angular-velocity recorder. An instrument that measures and records angular velocity about an axis.

anhedral, noun. [Greek *an-* ("not") + *dihedral*.] A negative dihedral; anhedral angle.

anhedral angle. The angle of negative dihedral. See **DIHEDRAL ANGLE** and note.

annular airfoil. An airfoil which, as viewed from its leading or trailing edge, has an annular shape, generated by the rotation of its section about an axis parallel, or nearly parallel, to its chord. Also called a "ring airfoil."

annular combustion chamber. A combustion chamber of annular cross section (i. e., having circular inner and outer boundaries), completely surrounding the engine shaft between the compressor and turbine of a gas-turbine engine.

anoxia, noun. *Med.* Complete deprivation of oxygen; oxygen deprivation serious enough to cause death; loosely, **HYPOXIA**.

antidrag wire. A wire in certain kinds of wing structures, running from an inboard point near the trailing edge to an outboard point near the leading edge, designed to resist forces acting on the wing in the direction of flight. Cf. **DRAG WIRE**.

anti-g suit. Same as **G-SUIT**.

anti-icer, noun. A device or substance for the prevention of ice formation. Cf. **DE-ICER**.

anti-icing, noun. The prevention of ice formation upon an aircraft's surfaces, in its engine induction system, or elsewhere, either by heat or by use of substances such as oil or alcohol. Cf. **DE-ICING**.

antiknock agent. A fuel additive, such as tetraethyl lead, used to decrease knock or detonation.

antilift wire. Same as **LANDING WIRE**.

antipropeller end. That end of an engine opposite the end to which the propeller is attached.

antispin parachute. A parachute deployed from an aircraft to overcome or prevent spin.

antitorque rotor. On some helicopters, a small rotor or airscrew, usually located at the tail and rotating in a plane substantially parallel to the plane of symmetry, which furnishes a thrust counteracting the torque of the main rotor and provides directional control for the helicopter. Cf. **TAIL ROTOR**.

aperiodic compass. A magnetic compass having a highly damped indicator to prevent overswing or oscillation.

apex, noun. Of a parachute, the crown of the canopy.

apparent additional mass. A mass of fluid carried along with a body moving in a fluid and apparently added to the mass of the body.

The apparent additional mass has inertia and momentum equal to the apparent increase of the inertia and momentum of the body. The term and concept are chiefly applicable to simple, symmetrical, and streamlined bodies, such as airship hulls and balloons, in an incompressible fluid.

appendix, noun. A tube or sleeve on a balloon, usually located at the bottom, used principally for inflation and deflation. See **INFLATION SLEEVE**.

approach, noun. 1. An act or instance of bringing an aircraft in to a landing, or of an aircraft coming in to a landing, including flying a landing pattern

and descending, as, to begin an *approach*, or, to make a landing in the first *approach*. 2. An access, way, or avenue through which aircraft are brought in to land, as, a clear *approach*. 3. The flight path or line of movement of an aircraft in an approach, as, to fly a straight *approach*.

See **FINAL APPROACH**, **GROUND-CONTROLLED APPROACH**, **INITIAL APPROACH**, **INSTRUMENT APPROACH**, **POWER APPROACH**.

approach control. The supervision and direction of air traffic arriving at, departing from, and flying in the vicinity of an airfield, under instrument flying conditions; [*Usually capitalized.*] a service or organization providing this control.

—approach controller.

approach light. Any one of a line of lights indicating the direction of approach to a runway or strip, marking the center line of a runway or water lane, etc.

approach pattern. The flight pattern flown by an aircraft in making an approach to a landing. Also called a "landing pattern."

apron, noun. An area, ordinarily paved, for parking or handling aircraft.

area ratio. The ratio of one area to another; e. g., the ratio between the exit area and the throat area of a rocket nozzle.

area rule. A prescribed method of design for obtaining minimum zero-lift drag for a given aerodynamic configuration, such as a wing-body configuration, at a given speed. For a transonic body, the area rule is applied by subtracting from, or adding to, its cross-sectional area distribution normal to the airstream at various stations so as to make its cross-sectional area distribution approach that of an ideal body of minimum drag; for a supersonic body, the sectional areas are frontal projections of areas intercepted by planes inclined at the Mach angle.

area-ruled, adj. Of an aircraft or other body or configuration: Designed or built in accordance with the area rule.

arrested landing. An airplane landing in which the landing roll is shortened by arresting gear.

arrester gear. Same as **ARRESTING GEAR**.

arresting gear. Any gear or apparatus designed to arrest something in its motion, either all or part of such gear being external to the object being arrested; specif., any such apparatus used (e. g., in carrier landings) to arrest airplanes in the landing roll. Airplane arresting gear in its commonest form comprises a hook (arresting hook) on the airplane; a cable, wire (arresting cable, arresting wire), or the like, usually several, stretched across the deck or runway in the path of the airplane and which engages the arresting hook; and shock-absorbing devices.

arrow engine. Same as W-ENGINE.

arrowhead wing, or arrow wing. A wing of V-shaped planform, either tapering or of constant chord, suggesting a stylized arrowhead.

articulated rotor. On a rotary-wing aircraft, a rotor having its blades hinged, usually so as to allow both flapping and lagging motions.

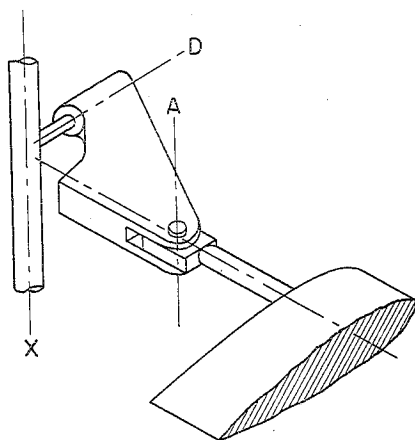

Articulated rotor blade. A alpha (drag) hinge; D delta (flapping) hinge; X axis of rotation.

artificial feel. A control feel simulated by mechanisms incorporated in the control system of an aircraft where the forces acting on the control surfaces are not transmitted to the cockpit controls, as in the case of an irreversible control system or a power-booster system. See CONTROL FEEL.

artificial horizon. 1. A gyro-operated flight instrument that shows the pitch-

ing and banking attitudes of an aircraft with respect to the horizon, within limited degrees of movement, by means of the relative position of lines or marks on the face of the instrument representing the aircraft and the horizon. See ATTITUDE GYRO, sense 1. 2. A device, such as a spirit level, pendulum, etc., that establishes a horizontal reference in a navigation instrument.

ascend, verb intr. To move or rise upward—with reference to balloons, sometimes used in preference to "climb."

A-scope, noun. A type of radarscope that presents range only, usually on a vertical scale, but in some modified versions on a horizontal scale.

aspect ratio. The ratio of the square of the span of an airfoil to the total airfoil area, or the ratio of its span to its mean chord.

An airfoil of high aspect ratio is of relatively long span and short chord; one of low aspect ratio is of relatively short span and long chord. See EFFECTIVE ASPECT RATIO.

ASR—Abbreviation for airport surveillance radar.

assisted take-off. A take-off assisted by a supplementary source of power, usually rockets. See RATO, sense 1.

astral dome. Same as ASTRODOME.

astrocompass, noun. An instrument used to determine direction by sighting heavenly bodies of known position. See SUN COMPASS.

astrodome, noun. A transparent dome in the fuselage or body of an aircraft, intended primarily to permit taking celestial observations in navigating. Also called a "navigation dome."

athodyd, noun. [Coined from "aero-thermodynamic duct."] A type of jet engine consisting essentially of a duct or tube of varying diameter and open at both ends, which admits air at one end, compresses it by the forward motion of the engine, adds heat to it by the combustion of fuel, and discharges the resulting gases at the other end to produce thrust.

The ramjet is an athodyd; the pulsejet, especially the earlier type, is usually not considered an athodyd.

atmosphere, noun. 1. The body of air surrounding the earth; also, the body of gases surrounding or comprising any planet or other celestial body. 2. *Physics.* A unit of pressure equal

to 14.70 pounds per square inch, representing the atmospheric pressure at mean sea level under standard conditions, as, a pressure of two atmospheres. See STANDARD ATMOSPHERE.

attached shock wave, or attached shock. An oblique or conical shock wave that is in contact with the leading edge or the nose of a body in a supersonic flow field.

attached-type parachute. A parachute that is opened automatically in the jump or drop by means of a line attaching the ripcord or parachute pack to the aircraft. It is used, e. g., by paratroopers and for dropping supplies. Cf. FREE-TYPE PARACHUTE.

attitude, noun. The position or orientation of an aircraft, rocket, etc., either in motion or at rest, as determined by the relationship between its axes and some reference line or plane or some fixed system of reference axes. See FLIGHT ATTITUDE.

attitude control. 1. The control of the attitude of an aircraft, guided missile, etc. 2. A device or system that automatically provides control of attitude, esp. of a guided missile or other pilotless vehicle.

attitude gyro. 1. A gyro-operated flight instrument that indicates the attitude of an aircraft with respect to the earth throughout 360° of rotation about each axis of the aircraft. This instrument is similar to the artificial horizon, but has greater angular indication. 2. Broadly, any gyro-operated instrument that indicates the attitude of an aircraft.

auger, verb intr. To auger in. To spin to earth in an airplane and crash. *Stang.*

augmented thrust ratio. The ratio of the augmented thrust of an engine to its normal thrust. See THRUST AUGMENTATION.

augmenter tube. A tube or pipe, usually one of several, through which the exhaust gases from an aircraft reciprocating engine are directed esp. to provide additional thrust.

aural null. A condition existing when no audible signal or when a minimum audible signal is received by a radio direction-finder or radio compass, indicating that the plane of its loop

antenna is perpendicular to the direction of a radio wave.

autogiro, noun. [Originally a trade name; sometimes capitalized.] A rotary-wing aircraft whose rotor is turned throughout its flight by air forces resulting from the motion of the craft through the air, with lift over the rotor equalized by vertical oscillation (flapping) of the sustaining airfoils. Forward propulsion is independent of the rotor. Cf. GYROPLANE and see ROTARY-WING AIRCRAFT.

The autogiro (developed by Juan de la Cierva (1895-1936) in the 1920's and not manufactured in recent years) is capable of taking off and landing in a small area and of very low-speed flight; with an unpowered rotor, however, it is not capable of vertical ascent nor sustained hovering. Different devices were incorporated in some autogiros to power or spin the rotor momentarily, esp. so as to permit the "jump take-off." Some autogiros were equipped with stub wings in addition to the rotor.

autogyro, noun. Variant of "autogiro."

autoignition, noun. Specif., the automatic or spontaneous ignition of the fuel-air mixture, or a portion of it, in an engine cylinder, caused, e. g., by high cylinder temperature.

auto-lean, noun. A fuel-air mixture setting providing the leanest fuel-air mixture feasible for efficient operation at cruising speeds, automatically compensated for changing altitudes.

automatic boost control. A control system or regulator that automatically operates to maintain a selected engine manifold pressure under varying operating conditions.

automatic direction finder. A type of radio compass which, when properly tuned to a radio transmitting station, automatically indicates the direction of the station in relation to the heading of the aircraft, without the 180-degree ambiguity (which see) characteristic of other types of radio compasses. The loop antenna of the automatic direction finder is rotated to the proper position for direction indicating by an electric motor operated by variations in the signal received in the loop. The automatic direction finder is sometimes called an "automatic radio compass," or "radio compass." See ADF and RADIO COMPASS.

automatic mixture control. A carburetor control system that automatically maintains a desired fuel-air mixture

ratio under different operating conditions.

automatic pilot. A device or apparatus that automatically controls the flight of an aircraft, guided missile, etc. to some extent; usually, a device that automatically maintains the attitude of an aircraft, missile, etc. and steers it in a desired path.

automatic propeller. A propeller incorporating a mechanism that automatically maintains the blade angle of the blades at the most favorable angle for different operating conditions, as for take-off, cruising, diving, etc.

automatic radio compass. Same as AUTOMATIC DIRECTION FINDER.

automatic slot. A slot in the leading edge of a wing created by the movement of a slat that is retained in the leading-edge contour of the wing at most angles of attack, but automatically lifting away to create the slot as the stalling angle is approached. Cf. FIXED SLOT.

automatic stability. Stability achieved with the controls operated by automatic devices, as by an automatic pilot.

autopilot, noun. Same as AUTOMATIC PILOT.

auto-rich, noun. A fuel-air mixture setting providing a rich fuel mixture, automatically compensated for changes in altitude.

autorotate, verb intr. 1. To rotate from the effects of a passing airstream, without application of mechanical force—said esp. of the rotor of an autogiro, helicopter, or the like. Cf. WINDMILL, verb. 2. Of an airplane: To roll or rotate uncontrolled, as in a spin.

—autorotation, noun, autorotative, adj.

autosyn, noun. [A trade name, from "auto-synchronous"; often capitalized.] A remote-indicating instrument or system based upon the synchronous-motor principle, in which the angular position of the rotor of one motor at the measuring source is duplicated by the rotor of the indicator motor, used, e. g., in fuel-quantity or fuel-flow measuring systems, position-indicating systems, etc. See SYNCHRONOUS MOTOR.

auxiliary airfoil. A secondary airfoil, such as a slat, flap, or tab, that supplements or aids in some manner, as by

creating an additional force or by providing a smooth airflow.

auxiliary landing gear. That part of a landing gear consisting of a nose wheel or tail wheel, outboard floats or wheels, or other components which in general are intended to stabilize the aircraft on the surface and not to bear a significant part of the weight.

auxiliary spar. A secondary or supplementary spar used to provide extra strength or attachment points.

auxiliary-stage supercharger. Any supercharger supplementing the main-stage supercharger, used esp. at the higher altitudes. When two or more auxiliary-stage superchargers are used, the auxiliary discharging directly into the main supercharger is called the "first auxiliary." See MAIN-STAGE SUPERCHARGER.

aviation, noun. 1. The art, science, practice, or field of endeavor of flying or operating heavier-than-air aircraft, as, fifty years of aviation, or, radio frequencies used for aviation. 2. A group or organization engaged in, or dedicated to, aviation (in sense 1), as, the mission of military aviation.

aviation medicine. That branch of medicine dealing with the effects of flight upon the human body, or with the demands of the human body under the various environmental conditions of flight. Aviation medicine is concerned with the effects of acceleration, with the effects of flight at high altitudes, with the psychological effects brought about by flying, with the design of aircraft and equipment to meet the body's needs, etc.

aviator, noun. One who pilots a heavier-than-air aircraft, or one skilled in piloting heavier-than-air aircraft—applied esp. to a male person, but sometimes applied to a female and commonly modified, as, a woman aviator. Cf. AERONAUT, AVIATRIX.

aviatrix, noun. A female aviator.

avigation, noun. Same as AIR NAVIGATION. Rare.

avionics, noun. [Aviation+electronics.] Electronics as applied esp. to aviation.

axial compressor. Same as AXIAL-FLOW COMPRESSOR.

axial engine. Same as BARREL ENGINE. Cf. AXIAL-FLOW ENGINE.

axial-flow compressor. A rotary compressor having intervening rows or stages of rotary and stationary blades, through which the movement or flow of fluid is substantially parallel to the rotor's axis of rotation. Cf. CENTRIFUGAL COMPRESSOR.

axial-flow engine. A gas-turbine engine having an axial-flow compressor.

—axial-flow gas-turbine engine, axial-flow turbojet engine, axial-flow turboprop. See AXIAL-FLOW COMPRESSOR, GAS-TURBINE ENGINE, and TURBOJET ENGINE (illus.).

axial load. A load directed along the axis of a member.

axis, noun. 1. a. A line passing through a body, about which the body rotates or may be assumed to rotate. b. Any arbitrary line of reference, such as a line about which the parts of a body or system are symmetrically distributed. c. A line along which a force is directed, as, an axis of thrust. 2. Specif., any one of a set or system of mutually perpendicular reference axes, usually intersecting at the center of gravity of an aircraft, rocket projectile, or the like, about which the motions, moments, and forces of roll, pitch, and yaw are measured.

Three different sets of reference axes as described in sense 2 are commonly used: *body axes*, *wind axes*, and *stability axes*. Each set of axes contains a *longitudinal axis* (the X-axis), running fore and aft; a *lateral axis* (the Y-axis), going from side to side; and a *vertical axis* (the Z-axis), going from top to bottom. (These axes are taken with the aircraft or other body assumed in a horizontal, upright position.) The body axes are fixed in the body and move with it; the wind axes are established by the direction of the undisturbed airflow relative to the body, the X-axis being parallel to the direction of flow; and the stability axes are established with the X-axis parallel to the undisturbed airflow in the vertical plane (with respect to the body), but coincident with the body X-axis in the lateral plane, and therefore free to yaw. Reference is sometimes made to *tunnel axes*, which are the geometrical axes of a wind tunnel and ordinarily coincide with the tunnel-wind axes. Their designations are as for the other sets of axes.

The positive directions for all these axes are customarily taken as follows: forward, or opposite to the direction of airflow, for the X-axes; to starboard for the Y-axes; and downward for the Z-axes.

In sense 1a, see AERODYNAMIC AXIS, ELASTIC AXIS, NEUTRAL AXIS, WING AXIS; in sense 1b, see EARTH AXIS; in sense 2, see PITCH AXIS, ROLL AXIS, YAW AXIS.

axis of no feathering. In a rotary-wing system, an axis with respect to which the rotor blades do not change their

blade angles for first harmonic blade motions. Sometimes called a "no-feathering axis." See CONTROL AXIS.

axis of no flapping. In a rotary-wing system, an axis with respect to which there is no first harmonic flapping of the blades. Sometimes called a "no-flapping axis."

axis of rotation. An axis about which rotation occurs (see AXIS, sense 1); specif., the mechanical axis of rotation (usually the powered shaft axis) of a helicopter or similar craft—often disting. from an axis of no feathering, etc.

axis of thrust. Same as THRUST AXIS.

azimuth, noun. 1. a. Horizontal direction or bearing, as, to find the azimuth (of something). b. Nav. The horizontal direction of a celestial body with respect to a terrestrial reference direction, usually measured clockwise from a northern reference direction through 360°, and so disting. from azimuth angle (see AZIMUTH ANGLE, sense b)—also disting. from bearing (which see, sense 1). 2. A vertical plane, as, to establish a flight path in azimuth, or, the stability of a rotor blade in azimuth. 3. The measure of azimuth, i. e., azimuth angle.

azimuth angle. An angle expressing a horizontal or lateral direction or relationship, as: a. The angle between the blade-span axis of a rotor blade and its projection on the plane of symmetry of the rotorcraft, measured in the direction of rotation from a point on the plane of symmetry downstream of the rotor axis. Sometimes called "blade azimuth angle." b. Nav. An angle expressing the horizontal direction of a celestial body with respect to a terrestrial reference direction; specif., this angle measured from north or south clockwise or counterclockwise through 90° or through 180°, and so disting. from azimuth (which see, sense 1b). c. An angle expressing the horizontal direction of an object, such as an airborne aircraft, with respect to a reference direction.

azimuth control. 1. Control over movement or direction in azimuth. 2. A control system or device for control in azimuth, such as the cyclic-pitch control system of a helicopter.

B

back, noun. 1. A BLADE BACK. 2. The upper part or surface of an aircraft (the aircraft being considered in an upright position), esp. the upper part of an airplane.

backfire, noun. 1. An explosion or combustion in the intake or exhaust passages of an engine. 2. A backward flow of fire or flaming gases in a system.

backfire screen. A screen to block the progress through a system of a backfire; specif., a screen in the intake manifold of an engine to prevent backfire from progressing through the induction system, or through some part of the system.

backlash, noun. In an aircraft control system, a looseness or play in the linkage between the cockpit controls and the control surfaces, or between the cockpit controls and a mechanical "feel" system.

back-pack parachute. A parachute or parachute pack worn on the person's back.

back pressure. 1. Pressure exerted backward; in a field of flow, a pressure exerted contrary to the pressure producing the main flow. 2. EXHAUST BACK PRESSURE.

backswEEP, noun. Same as SWEEPBACK.

—backswEpt, *adj.*

back-to-chest acceleration. *Av. med.* Accelerating force acting on the human body in the direction from the back to the chest, as occurs when seated facing forward in an aircraft moving with increasing speed. It is a type of transverse acceleration. See TRANSVERSE ACCELERATION.

affle, noun. A plate, grating, or the like used esp. to block, hinder, or divert a flow or to hinder the passage of something, as: a. A plate used to conduct, or help to conduct, a flow of cooling air around an engine cylinder. See PRESSURE AFFLE. b. A plate, wall, or the like in a fuel tank or other liquid container, used esp. to prevent sloshing of the contents. c. A ridge or wall on the top of a piston in a two-stroke-cycle engine, used to deflect the incoming mixture upward and divert it from the exhaust port. d. A plate in the forward section of a pitot tube,

used to reduce turbulence in the tube and to prevent dirt, moisture, etc., from entering the system. See PITOT-STATIC TUBE (illus.).

bag, noun. 1. A flexible envelope or container for holding liquid, gas, compressed air, etc., sometimes used as a fuel tank in aircraft, as a float on a helicopter, etc. 2. Specif., a large, flexible envelope, container, or cell for holding the aerostatic gas of a balloon or airship. Sometimes called a "gas bag" (which see).

bail, verb intr. *Usually, to bail out.* To jump or leap with a parachute from a flying aircraft, esp. from an aircraft in distress—not commonly applied to exhibition parachute jumps, etc., and not applied to paratroop jumps.

bailout, noun. An act or instance of bailing out. See BAIL.

bailout oxygen bottle. A portable metal cylinder or tank containing oxygen to be used for breathing after parachuting out at a high altitude. Sometimes shortened **bailout bottle.**

balance, noun. 1. The equilibrium attained by an aircraft, rocket, or the like when forces and moments are acting upon it so as to produce steady flight, esp. without rotation about its axes; also used with reference to equilibrium about any specified axis, as, an airplane in **balance** about its longitudinal axis. See TRIM, *noun*. 2. A weight that counterbalances something, esp., on an aircraft control surface, a weight installed forward of the hinge axis to counterbalance the surface aft of the hinge axis. See BALANCED CONTROL SURFACE, MASS BALANCE, *sense* 2. 3. The condition existing when a shaft, pulley, flywheel, or other rotating part or component has its mass so disposed about its axis of rotation that it will remain stationary about that axis when turned to any position—hence, engine **balance**; the state of an engine when all of its rotational parts are in such **balance**.

balanced control surface. A control surface that is in a desired condition of equilibrium about its hinge axis. Such a surface may be balanced for either static or aerodynamic conditions. See

AERODYNAMIC BALANCED SURFACE, STATIC BALANCED SURFACE.

balance tab. Same as BALANCING TAB.

balancing plane, or balancing surface.

An early name for a control surface.

balancing tab. A tab (which see) so linked that when the control surface to which it is attached is deflected the tab is deflected in an opposite direction, creating a force which aids in moving the larger surface. Sometimes called a "geared tab."

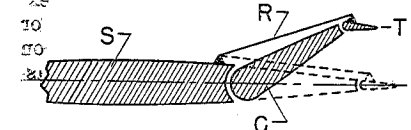

Balancing tab. T balancing tab; C control surface; R push rod; S fixed surface.

ball, noun. The ball in a bank indicator—used in contexts such as "Center the ball."

ballast, noun. Any substance, usually sand or water, put aboard an airship or balloon to help stabilize it or to afford a means of altitude control; any substance, object, or accumulation of objects used to weight an airplane, rocket, etc. so as to achieve a desired trim or balance in flight. Ballast is sometimes used in test flights in place of passengers, cargo, etc.

ballast tank. A tank for water ballast, as used esp. aboard a lighter-than-air aircraft.

ball-bank indicator. A BANK INDICATOR.

ballistic missile. A missile designed to operate primarily in accordance with the laws of ballistics.

A ballistic missile is guided during a portion of its flight, usually the upward portion, and is under no thrust from its propelling system during the latter portion of its flight; it describes a trajectory similar to that of an artillery shell. The German V-2 of WW II is an early example of this kind of missile.

ballistics, noun. [See note.] The science that deals with the motion, behavior, and effects of projectiles, esp. bullets, aerial bombs, rockets, or the like; the science or art of designing and hurling projectiles so as to achieve a desired performance. See EXTERIOR BALLISTICS, INTERIOR BALLISTICS, TERMINAL BALLISTICS.

For the derivation of the word "ballistics" and a historical account of the science, see Edward J. McShane *et al.*, *Exterior Ballistics* (University of Denver Press, 1953), "Historical Appendix," pp. 742 ff.

484035—59—3

ballonet, noun. [The "t" is not silent.]

A gas-tight compartment within the main envelope of certain balloons or (usually one of a pair) within the envelope of a pressure airship, inflated with air or deflated to compensate for changes in the gas volume in the main envelope (hence maintaining a desired pressure and shape) and to assist in the trim of the aircraft.

ballonet ceiling. The altitude from which a pressure airship, beginning with empty ballonets, can return to sea level without loss of operating pressure.

balloon, noun. 1. A nonpowered (and nonsteerable) aircraft incorporating, or consisting of, a bag inflated with air or gas lighter than the surrounding air to give it buoyancy. See note. 2. Restrictively, the bag or envelope only of such an aircraft; also, the gasbag of a pressure airship. 3. Any lighter-than-air aircraft, as used esp. in terms or phrases such as "dirigible balloon," "navigable balloon," etc.

The first balloon (also the first successful aircraft) was a hot-air balloon, invented by the brothers Jacques and Joseph Montgolfier, in France, in 1783; the aerostatic principle was understood long before that time, however. Later in the same year Pilâtre de Rozier (1754-1785), accompanied by a passenger, made a free flight in a fire balloon, the two men thus becoming history's first aeronauts. Also in that year, hydrogen came into use for balloon inflation.

The balloon, while still used to a limited extent for sporting purposes, is today principally employed in meteorology and high-altitude observation; it is obsolete for its traditional use of military observation.

See BARRAGE BALLOON, CAPTIVE BALLOON, CEILING BALLOON, FIRE BALLOON, FREE BALLOON, HOT-AIR BALLOON, KITE BALLOON, MONTGOLFIER, PILOT BALLOON, SKYHOOK, SOUNDING BALLOON.

balloon, verb intr. 1. Of an airplane, helicopter, or the like: To rise slightly, either just before or just after touchdown, as a result of an increased angle of attack or of a "cushion" of air between aircraft and ground. See FLOAT, *verb*, *sense* 2. 2. Of a parachute, of fabric aircraft covering, etc.: To swell out or distend in a manner similar to that of a balloon.

balloonist, noun. One who pilots, rides in, or serves as a crew member in a balloon; also sometimes applied to a crew member or passenger on a dirigible. *Popular.* See AERONAUT.

balloon pilot. A person who pilots, or is trained to pilot, a lighter-than-air air-

craft, esp. a free balloon. See FREE BALLOON, note.

ball turret. An aircraft gunner's turret having a ball-like shape, which projects or is let down from the belly of the aircraft.

bang-bang control. [See note.] Flicker control, esp. as applied to guided missiles. See FLICKER CONTROL.

"Bang-bang" in this term is imitative, arising from the noise made by control mechanisms slamming first to one side, then to the other, in tests of this sort of control.

bank, noun. 1. The position or attitude of an airplane, glider, helicopter, or the like when its lateral axis is inclined to the horizontal, as, to put an airplane into a *bank*. This is the position normally assumed by an aircraft when turning. A *right bank* is a bank in which the lateral axis inclines downward to starboard. 2. The inclination of the lateral axis of an airplane, etc., to the horizontal, as, the degree of *bank*. 3. A line, tier, stand, or layer of like things or objects, as, a *bank* of rockets; specif., a line of cylinders in an in-line engine, as, the left *bank* of a V-engine.

In senses 1 and 2, "bank" is primarily a flier's term; the aerodynamicist or aeronautical engineer prefers "roll." See ROLL, *noun*, sense 1.

bank, verb. 1. *tr.* To incline (an airplane, glider, helicopter, etc.) laterally, esp. in making a turn. 2. *intr.* To incline laterally—said of an aircraft or persons within.

bank-and-climb gyro unit. A unit incorporating a vertical-axis gyroscope, used in an automatic pilot for lateral and longitudinal indication and control.

bank-and-turn indicator. Same as TURN-AND-BANK INDICATOR.

bank angle. Same as ANGLE OF BANK.

bank indicator. A flight instrument consisting of a ball enclosed in a slightly curved transparent tube filled with a damping liquid, the position of the ball in the tube being intended esp. to indicate skidding or slipping in a turn. This instrument is commonly mounted in the same case with a turn indicator to make the turn-and-bank indicator.

Bárány chair. [After Robert Bárány (1876-1936), Swedish physician.] A kind of chair in which a person is revolved to test his susceptibility to vertigo.

barnstorm, verb intr. To travel about in an airplane or in airplanes, visiting rural areas especially, taking paying passengers for joy rides and often performing exhibition flights.—*tr.* To tour (the country or a place) performing these actions.

"I've barnstormed over half of the forty-eight states." Lindbergh.

barnstormer, noun. One who barnstorms.

barograph, noun. A recording barometer; also, *loose usage*, an ALTIGRAPH.

See MICROBAROGRAPH.

barometer, noun. An instrument that measures atmospheric pressure. A barometer commonly employs for its purpose either a column of mercury in a glass tube, balanced by the pressure of the atmosphere, or a partially evacuated and sealed capsule responsive to pressure changes. See ANEROID, *noun*, STATOSCOPE.

barometric altimeter. Same as PRESSURE ALTIMETER.

barometric fuel control. A control device that regulates the fuel flow to a gas-turbine engine according to the barometric pressure and impact pressure at different altitudes. Cf. ALTITUDE MIXTURE CONTROL.

barrage balloon. A captive balloon, usually one of several, whose mooring cable serves to discourage low-flying air attack.

barrel engine. An internal-combustion reciprocating engine having the cylinders parallel to its drive shaft or long axis—usually a nonrotary engine, but barrel rotaries have been made.

Also called an "axial engine." See CAM ENGINE (illus.).

barrel roll. 1. An aerobatic performance in which an airplane is made to roll while simultaneously revolving about an offset axis, describing a corkscrew flight path. 2. Loosely, a SLOW ROLL or a SNAP ROLL.

barricade, noun. On an aircraft carrier, a net designed to trap and halt a landing airplane in case of failure or malfunction of the arresting gear and barrier system. See BARRIER, sense 1.

barrier, noun. 1. An emergency arresting device across a runway or a carrier deck that engages the landing gear of a landing airplane in the event of failure or inadequacy of the airplane

brakes or of the ordinary arresting gear. See BARRICADE. 2. Figuratively, a hindrance to high-speed flight. See SONIC BARRIER, THERMAL BARRIER.

base, noun. 1. A place where aircraft, usually military or naval aircraft, are stationed and out of which they operate; an air base. See AIR BASE, sense 1, SEAPLANE BASE. 2. The aft end of a projectile or certain other bodies.

base drag. Drag owing to a base pressure lower than the ambient pressure. It is a part of the pressure drag. See BASE PRESSURE, PRESSURE DRAG.

base leg. That segment or portion of an approach pattern approximately at right angles to the final approach.

base line. 1. A horizontal line from which vertical measurements are made, or upon which ordinates are plotted, as: a. A line in the plane of symmetry of a seaplane float or hull, just inside the keel plate and parallel to the water lines, from which vertical measurements are made; also, the axis of a body of revolution from which a seaplane float or hull design is derived. b. A line representing the maximum length of an airship, upon which ordinates representing cross-sectional areas are plotted. 2. A line joining a master loran station with its slave station. 3. An electronically drawn line on a radar screen, representing the track of the scanner, with echoes from reflecting objects appearing as bright spots in the line.

base pressure. The pressure exerted on the base, or extreme aft end, of a body, as of a cylindrical or boattailed body or of a blunt-trailing-edge wing, in a fluid flow.

basic airspeed. An airspeed value derived by correcting indicated airspeed for installation and instrument errors.

basic dry rating. The thrust under standard sea-level conditions of a jet engine not using afterburning, water injection, or other methods of thrust augmentation.

basic lift. The lift of a given airfoil section when the lift on the entire airfoil is zero. This lift depends upon the twist of the wing.

basic load. The load on an aircraft or other flying vehicle, or on a member or part thereof, under a specified condition of static equilibrium.

basket, noun. 1. An open container or car, often of wickerwork, suspended beneath a balloon for carrying persons, ballast, etc. 2. A BURNER BASKET.

batten, noun. 1. A strip or bar temporarily secured to a wing or tail to prevent movement of the control surface. 2. Any one of a number of radial stiffening members at the nose of a pressure airship. 3. A light, flexible strip of wood or other material used in lofting for drawing curved lines.

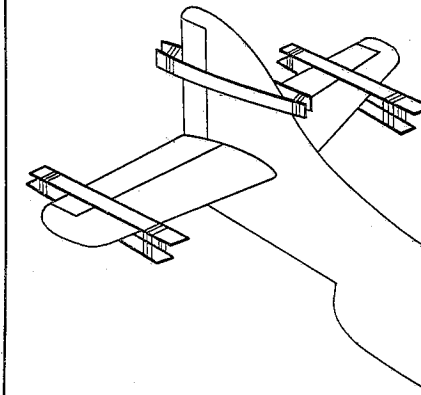

Illustrating use of battens, sense 1.

battery cart. A cart containing a series of electrical batteries, used to start aircraft engines on the ground and thus conserve power in any batteries installed aboard.

bay, noun. A space or section between adjacent members of a truss or framework, as: a. The space between two sets of interplane struts in a biplane or other multiplane, or the space between a set of interplane struts and the other points of attachment of the wings at or near the fuselage. A *single-bay biplane* has one bay on each side of the fuselage, i. e., one set of interplane struts to a side. b. The more or less rectangular area enclosed between two adjacent longitudinal members and two adjacent cross braces in a fuselage truss. c. The space, section, or compartment between two bulkheads, wing ribs, or other structural members of an aircraft, in which an engine or fuel tank is mounted, bombs or cargo are carried, etc.

beaching gear. Any wheeled device attached to a seaplane or flying boat to permit moving it onto the beach or

shore, and to move the craft about ashore.

beacon, noun. A light, group of lights, electronic apparatus, or other device that guides, orients, or warns aircraft, guided missiles, etc. in flight, or vessels at sea; a structure, building, or station where such a device is mounted or located. See LIGHT BEACON, RADAR BEACON, RADIO BEACON.

beam, noun. 1. The breadth of an aircraft's hull, a fuselage, a float, or a vessel at its widest part. 2. The direction away from the side of an aircraft or vessel at right angles to its longitudinal axis, as, an attack from the *beam*. 3. A stream of radio or radar signals, light rays, or the like; specif., the directional signals in a radio range.

beam-climber guidance. Same as BEAM-RIDER GUIDANCE.

beam-rider guidance. A system for guiding missiles in which a missile follows a radar beam, light beam, or other kind of beam directed along the path it is desired for the missile to follow. The beam used may be either fixed or moving, and the missile is provided with devices to detect its deviation from the beam and to return it to the beam automatically.

beam width. The angular width of a radio or radar beam, esp. the width of its central, effective portion, as measured between two specified reference lines; specif., the width of a radar beam measured between lines of half-power intensity.

bearing, noun. 1. The horizontal direction of an object or point, usually measured clockwise from a reference line or direction through 360°. In navigation, bearing is used with reference to the direction of a terrestrial object or point, as disting. from azimuth (which) see, sense 1b). See COMPASS BEARING, GRID BEARING, MAGNETIC BEARING, RELATIVE BEARING, TRUE BEARING. 2. An angular measurement expressing bearing.

belly, noun. The underside of an aircraft's fuselage or body—not ordinarily applied to the underside of a flying boat. Cf. BOTTOM.

belly-land, verb. 1. *tr.* To land (an airplane) on its belly without use of landing gear. 2. *intr.* To make a landing as described in sense 1—said of aircraft or persons within.

—belly landing, *noun.*

belly tank. A detachable or droppable auxiliary fuel tank designed to be attached to the belly of an airplane.

belt, noun. A SAFETY BELT.

bend, verb. 1. *tr.* To bend a course. To alter the direction of a course in a four-course radio range so that it is no longer in line with its reciprocal course. Cf. SQUEEZE. 2. *intr.* Of a radio-range course: To change in direction at any place along its length owing to some external distorting influence.

bends, noun. Med. 1. The symptoms or characteristics of aeroembolism. 2. Same as AEROEMBOLISM (in sense 2).

See AIR BENDS.

Bernoulli's law, or Bernoulli's theorem. [After Daniel Bernoulli (1700-1782), Swiss scientist.] In aeronautics, a law or theorem stating that in a flow of incompressible fluid the sum of the static pressure and the dynamic pressure along a streamline is constant if gravity and frictional effects are disregarded.

From this law it follows that where there is a velocity increase in a fluid flow there must be a corresponding pressure decrease. Thus an airfoil, by increasing the velocity of the flow over its upper surface, derives lift from the decreased pressure. See LIFT, sense 1 and note.

beveled control surface. A control surface having its trailing edge beveled so as to increase the trailing-edge angle and so provide aerodynamic balance.

bias construction. The construction of a parachute canopy such that the threads of each gore meet the peripheral hem or the center line of the gore at an angle of approximately 45 degrees.

biconvex airfoil. An airfoil profile whose sides are convex (circular-arc lines)—applied to such profiles that are symmetric about the chord.

bicycle landing gear. A main landing gear consisting chiefly of two wheels in tandem, or, more commonly, two units of which each has wheels side by side, the units being arranged in tandem.

A bicycle landing gear has the wheels or wheel units mounted along the longitudinal center line of the aircraft's fuselage. Out-rigger wheels are commonly required.

biplane, noun. An airplane having double-decked wings, one above the other. In most configurations, either the lower wing, or both the lower and upper wings, are divided by the fuselage.

biplane, adj. Having double-decked wings, mounted one above the other, as in *biplane* glider; having or consisting of surfaces double-decked, one above the other, as in *biplane* elevator, *biplane* rotor.

bipropellant, noun. A rocket propellant consisting of two unmixed or uncombined chemicals (fuel and oxidant) fed to the combustion chamber separately. See ROCKET PROPELLANT.

"Bipropellant" is used attributively in several self-explanatory phrases, such as bipropellant missile, bipropellant rocket engine or motor, bipropellant system, etc.

bird, noun. A guided missile. *Colloq.*

bi-signal zone. A zone formed by two overlapping signal patterns, as in a radio range, in which two signals are received. See EQUISIGNAL ZONE and LOOP-TYPE RADIO RANGE (illus.).

blackout, noun. 1. A condition in which vision is temporarily obscured by a blackness, accompanied by a dullness of certain of the other senses, brought on by decreased blood pressure in the head and a consequent lack of oxygen, as may occur, e. g., in pulling out of a high-speed dive in an airplane. This condition is sometimes followed by a loss of consciousness, but the unconsciousness is not usually regarded as a part of the blackout. Cf. GRAYOUT, RED-OUT. 2. *Radio.* A condition, brought on by natural causes and not owing to malfunctioning equipment, in which radio-receiving sets fail to pick up signals; also, a condition in which radio is not used, in accordance with edict.

blade, noun. 1. a. An arm of a propeller; a rotating wing. b. *Specif., restrictive,* that part of a propeller arm or of a rotating wing from the shank outward, i. e., that part having an efficient airfoil shape and that cleaves the air. See BLADE SHANK. 2. A VANE (in sense 2, which see), such as a rotating vane or stationary vane in a rotary air compressor, or a vane of a turbine wheel.

See BUCKET, sense 1, COMPRESSOR BLADE, IMPELLER BLADE, NOZZLE BLADE, PADDLE BLADE, PROPELLER BLADE, ROTOR BLADE, STATOR BLADE, TURBINE BLADE.

blade angle. The angle that a blade makes with some reference plane, as: a. The angle between the geometric chord or zero-lift chord of a propeller

blade and a plane perpendicular to the axis of rotation of the propeller. See PROPELLER (illus.). b. The angle between the chord of a rotor blade, usually the zero-lift chord, and a plane perpendicular to a reference axis through the rotor.

With twisted propeller or rotor blades, and consequently varying angle, the blade angle at three fourths or seven tenths of the radius from the axis of rotation is usually chosen to characterize the entire blade.

blade azimuth angle. The azimuth angle of a rotor blade. See AZIMUTH ANGLE, sense a.

blade back. The side of a propeller blade that faces forward, corresponding to the upper surface of a wing. See PROPELLER (illus.).

blade butt. The end of the propeller arm on certain types of propellers which is fastened to the hub—not said of a one-piece propeller.

blade cuff. Same as PROPELLER CUFF.

blade damper. A damper, such as a hydraulic damper, installed to act about the drag hinge of a rotor blade to reduce horizontal oscillation.

blade element. A segment of a blade, as a propeller blade or rotor blade, between two blade sections an infinitesimal distance apart.

blade-element theory. A theory in which a blade element is considered as a segment of a wing, lift and drag being calculated from the resultant velocity acting on the element.

blade face. The side of a propeller opposite the blade back, corresponding to the lower surface of a wing. Sometimes called the "load face" or "thrust face." See PROPELLER (illus.).

blade height. The length of a compressor or turbine blade from root to tip, exclusive of the imbedded root.

blade loading. The unit load sustained by the blades of a rotary-wing aircraft, determined by dividing the gross weight of the aircraft by the total planform area of its rotor blades. Cf. DISK LOADING.

blade pitch angle. Same as BLADE ANGLE (in all senses).

blade profile. The outline or form of a blade section.

blade radius. The radius of the circle described by the tip of a rotating blade, i. e., the distance from the blade tip to the axis of rotation. Also called "tip radius."

blade root. a. That part of a blade nearest the hub. See PROPELLER ROOT, ROTOR-BLADE ROOT. b. With turbine or axial-compressor blades, also applied to that part imbedded in the drum, disk, or wheel. See FIR-TREE ROOT.

blade section. A cross section of a blade; the profile of the cross section or the area defined by the profile. See AIRFOIL SECTION and note.

blade shank. The part of a propeller arm or rotating wing near the hub, i. e., between the blade (which see, sense 1b) and the hub. The blade shank of a propeller usually has a rounded or ovoid cross section, or, sometimes, an extremely thick airfoil section.

blade-span axis. A spanwise axis of a rotor blade, esp. the axis about which the blade is feathered.

blade stall. a. The condition occurring when a rotor blade operates at an angle of attack greater than the angle of maximum lift. b. Also applied to an analogous condition of the airflow across the blades of an air compressor. See COMPRESSOR STALL.

blade station. A particular place along a blade designating the distance from its axis of rotation or from some other reference, and used, e. g., to designate the point for measuring the blade angle, the location of a blade marking, or any other point or place under consideration.

blade-to-jet speed ratio. The ratio of the rotational speed of the blades of a turbine wheel, measured at the blade tips, and the speed of the jet stream or exhaust as it issues from the turbine nozzle.

blade twist. 1. The twist, or variation in the blade angle, built into a blade usually such that the blade angle decreases toward the tip. 2. A deformation of a rotor blade by unequal air forces, causing variation in the built-in blade angle from root to tip.

blade-width ratio. The ratio of the width of a blade, esp. a propeller blade (measured by the chord length), at a given blade station to the diameter of the circle described by the tip of the rotating blade. See MEAN BLADE-WIDTH RATIO.

blast chamber. A combustion chamber, esp. a combustion chamber in a gas-turbine engine, jet engine, or rocket

engine. *Popular.* See COMBUSTION CHAMBER and note.

blast deflector. *Specif.,* a type of deflector used to divert the blast of a rocket fired from a vertical position. See DEFLECTOR, sense b.

blast gate. Same as WASTE GATE.

blast vane. Same as JET VANE.

bleedback, noun. HOT-GAS BLEEDBACK.

blimp, noun. A nonrigid airship. *Colloq.*

blind, adj. Done under conditions of low visibility, using instruments, radio aids, or radar aids, as in *blind bombing*, *blind flying*, flying in which the pilot cannot see out, under either natural or simulated conditions.

blind, adv. Without being able to see out, as, to fly *blind*.

blip, noun. A spot of light or deflection of the trace on a radarscope, loran indicator, or the like, caused by the received signal, as from a reflecting object. Also called a "pip."

blister, noun. 1. A streamlined protuberance on an aircraft, often dome-shaped and sometimes transparent, designed to house machine guns or other equipment, to afford a place for observation, etc. 2. A curved sheet of water raised by the motion of a seaplane float or hull and separated from the water surface by an air space.

block, noun. Same as *chock*.

block time. The time taken by an aircraft to travel from its point of departure to its ultimate destination, measured from the moment the chocks or blocks are removed at the place of departure to the moment they are replaced at destination, time spent at intermediate stops being included in the total "block time."

block-to-block speed. The average speed made by an aircraft between removal of the chocks or blocks at the departure point and the replacing of the blocks at destination.

This term may be found variously understood in different contexts. The definition given is the most commonly accepted.

blowby, noun. The escape of gases or mixture past the rings of a piston engine during the compression or power stroke.

blowdown period. The period of time during which there is free expansion and discharge of gases through the exhaust valve or port of a reciprocating

engine, largely unaided by the motion of the piston or by the entrance of a fresh charge into the cylinder.

blowdown turbine. A turbine attached to a reciprocating engine which receives exhaust gases separately from each cylinder, utilizing the kinetic energy of the gases.

blowdown wind tunnel. A type of wind tunnel in which stored compressed air or other gas is allowed to expand through a test section to provide a stream of air or gas for model testing purposes.

blower, noun. 1. A rotary machine for blowing or compressing air; a fan or rotary pump. See AIR BLOWER. 2. A rotary supercharger driven by gears from the engine.

In sense 2, high blower and low blower designate the high and low rpm settings of the supercharger, or designate the supercharger when running at either setting.

blower ratio. The ratio of the rotational speed of the impeller in a geared supercharger to that of the engine crankshaft.

blowout, noun. A flameout; esp., a flameout caused by excessive air velocity. See FLAMEOUT, LEAN BLOWOUT, RICH BLOWOUT.

bluff body. A body having a broad, flattened front.

blush, verb intr. Of a doped fabric or surface: To become dull or pale as a result of rapid evaporation or high humidity, with a consequent weakening of the dope film.

boat, noun. A FLYING BOAT.

boattail, noun. The tapered rear portion of an elongated body having decreasing cross-sectional area toward the rear—applied esp. to bodies of revolution such as rockets or other projectiles.

body, noun. 1. The main part or main central portion of an airplane, airship, rocket, or the like; a fuselage or hull.

2. In a general sense, any fabrication, structure, or other material form, esp. one aerodynamically or ballistically designed, as, an airfoil is a *body* designed to produce an aerodynamic reaction.

body axis. Any one of a system of mutually perpendicular reference axes fixed in an aircraft or similar body and moving with it. See AXIS, sense 2 and note.

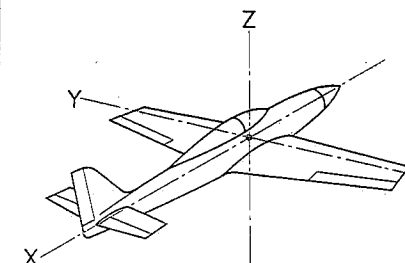

Body axes.

body of revolution. A symmetrical body, such as a bullet, having the form described by an element rotated about an axis.

bogie, noun. 1. A supporting and aligning wheel or roller on the inside of an endless track, used, e. g., in certain types of landing gear. 2. A type of landing-gear unit consisting of two sets of wheels in tandem with a central strut.

bomb bay. A bay in the fuselage of a bomber where bombs are normally carried. See BAY, sense c.

bomb-bay tank. An auxiliary fuel tank carried in a bomb bay.

bomber, noun. 1. An aircraft, esp. a fixed-wing airplane, that carries and drops bombs. 2. By extension, esp. in AF usage, a winged guided missile. See PILOTLESS BOMBER.

In sense 1, the unqualified word "bomber" commonly signifies an airplane, usually a large or multiengine airplane, that drops its bombs in horizontal flight. However, the term embraces a large class of airplanes widely varying in design, size, function, and employment. Following is a listing of different kinds of bombers; the meanings of these compounds can, in general, be gathered from an understanding of their elements:

Designated generally according to function or employment: attack bomber, day bomber, dive bomber, fighter-bomber, horizontal bomber, intercontinental bomber, long-range bomber, night bomber, reconnaissance bomber, strategic bomber, tactical bomber, torpedo bomber, etc.

Designated according to weight (also with connotations of size and range): light bomber, heavy bomber, medium bomber, very heavy bomber.

These designations are not inclusive.

In addition, there are many occasional distinctions or designations, such as atomic bomber, biplane bomber, supersonic bomber, etc.

bonding, noun. *Specif.,* a system of connections between all metal parts of an aircraft, forming a continuous electrical unit and preventing jumping or arcing of static electricity.

boom, noun. 1. A long, slender part, structure, or other object, such as a

beam or spar, extending out from something, as: a. A slender structure or piece, often one of a pair, that extends from the wings or main body of an aircraft to support the empennage or other tail component. Sometimes called a "tail boom." b. A polelike protuberance extending away from an aircraft (usually forward) into the undisturbed airflow, upon which or in which sensing devices are mounted for measurement purposes. c. A flexible pipe extended from a tanker aircraft, used in air refueling. See FLYING BOOM. 2. SONIC BOOM.

boost, noun. 1. Additional power, pressure, or force supplied by a booster, as, hydraulic *boost*. 2. A BOOSTER. 3. BOOST PRESSURE.

boost, verb tr. 1. To supercharge (in sense 1, which see). 2. To launch or to push along during a portion of flight, as to *boost* a ramjet to flight speed by means of a rocket, or a rocket *boosted* to altitude with another rocket.

booster, noun. 1. A device that provides extra power, thrust, or pressure, as: a. A device that applies force to move a control surface. See CONTROL BOOSTER. b. Any of various electrical devices for supplying additional current or voltage in a system. See BOOSTER COIL, BOOSTER MAGNETO. 2. One of the earlier stages of a multistage rocket. 3. A rocket system that propels a payload such as an artificial satellite. 4. An auxiliary rocket attached to an aircraft or other vehicle. A BOOSTER ROCKET.

booster coil. A coil connected to a battery to provide additional current, used esp. in an ignition system to provide extra voltage in starting an engine.

booster magneto. An auxiliary magneto that supplies high-tension current for starting an engine.

booster pump. A pump in a fuel system, oil system, or the like, used to provide additional or auxiliary pressure when needed.

booster rocket. A rocket that supplies temporary additional thrust to an aircraft, missile, or the like having other means of propulsion. A *rato* unit is one kind of booster rocket. See RATO.

boost pressure. Manifold pressure greater than the prevailing atmospheric pressure, obtained by supercharging. Often called "boost."

boost venturi. A small venturi ahead of the main venturi in a carburetor, for the purpose of increasing the metering force.

boot, noun. 1. A kind of container. See PARACHUTE BOOT. 2. A DE-ICER BOOT.

boss, noun. A thickened portion of a shaft, bar, rod, or the like, serving usually to provide a bearing surface, a place for screw threads, etc.; specif., the thickened central portion of certain propellers, esp. a wooden propeller.

bottom, noun. Specif., the underside of a seaplane hull or float, esp. that part of the underside that rests on the water. Cf. BELLY.

bottom camber. Same as LOWER CAMBER.

boundary layer. A thin layer of fluid next to the surface of a body in a moving stream (as an airfoil in an airstream) having distinctive flow characteristics as a result of friction between the fluid and the surface of the body. The flow in the boundary layer may be laminar, turbulent, or transitional between laminar and turbulent.

The flow velocity in the boundary layer increases from zero at the bounding surface with distance from the surface until it approaches the stream value. Boundary-layer thickness is measured from the surface to an arbitrarily chosen point, e. g., where the velocity is 99 percent of the stream velocity. See DISPLACEMENT THICKNESS, MOMENTUM THICKNESS.

boundary-layer control. The control of the flow in the boundary layer about a body or of the region of flow near the surface of the body in order to reduce or eliminate undesirable aerodynamic effects and hence to improve performance.

Boundary-layer control employs porous surfaces, suction slots, special attachments, or other devices to remove the boundary layer from the surface, to improve its stability, or otherwise to alter its characteristics.

boundary light. Any one of the lights marking the limits of a landing area. Boundary lights are commonly mounted on a cone-shaped boundary marker or are set flush with the surface.

boundary marker. A painted object, such as a cone or disk, used to mark the boundary of a landing area.

bound vortex. In aerodynamic theory, a hypothetical vortex assumed to lie in an airfoil and traveling with it and corresponding to the lifting forces acting on the airfoil. Cf. TRAILING VORTEX.

bow, noun. The forward part of something—applied in aeronautics to the forward part of an aircraft, esp. of an airship or flying boat, or to the forward part of a float. Cf. NOSE, *noun*.

bow cap. A cap of metal or fabric reinforcing the bow or nose of a pressure airship, or a conical or caplike piece to which the longitudinal girders are attached at the nose of a rigid airship.

bowheavy, adj. Having a tendency to sink at the bow—applied esp. to airships. Cf. NOSEHEAVY, STERNHEAVY.

bow stiffening. Battens or the like reinforcing the bow of a pressure airship against air pressure in flight. Also called "nose stiffening."

bow wave. 1. A shock wave in front of a body, such as an airfoil, or attached to the forward part of the body. 2. A water wave thrown up by the bow of a seaplane hull or float.

box rib. A built-up wooden rib consisting of a framework covered with wood on both sides, used at the junction of wing and fuselage on certain aircraft.

bracket, verb tr. To bracket a beam. To cross and recross a radio-range beam on a series of specified headings, making timed turns in order to determine the direction of the beam and to establish the proper heading for following the beam.

brake horsepower. The horsepower delivered at the rotating drive shaft of an engine. In calculations, this horsepower is usually corrected to comply with standard test conditions. See ACTUAL BRAKE HORSEPOWER and cf. SHAFT HORSEPOWER.

brake mean effective pressure. That part of the indicated mean effective pressure that produces the brake horsepower of an engine. See INDICATED MEAN EFFECTIVE PRESSURE.

brake parachute. Same as DECELERATION PARACHUTE.

brake specific fuel consumption. Specific fuel consumption based on brake horsepower. See SPECIFIC FUEL CONSUMPTION and note.

brake thermal efficiency. The thermal efficiency of an engine based on its brake horsepower, expressed as the ratio of the work delivered by the drive shaft of an engine during a given period of time to the total heat energy contained in the fuel burned during the

same period of time. See THERMAL EFFICIENCY.

braking rocket. A RETRO-ROCKET.

Brayton cycle. [After George B. Brayton, American engineer.] Same as JOULE CYCLE.

breakaway, noun. 1. The action of a boundary layer separating from a surface. 2. The action of an airplane breaking or leaving a formation, or suddenly changing course. 3. An acrobatic stunt performed on an airplane in flight in which the performer, attached to the plane by a cable invisible from the ground, falls off a wing; an act or instance of so falling off a wing.

breakaway cockpit unit. Same as EJECTION CAPSULE.

break cord. A cord attaching a static line to a parachute, which breaks after the parachute is deployed.

breathing, noun. The passage of air into or out of a gasbag, a crankcase, a fuel tank, or the like, caused by pressure changes; the action of a gasbag, a tank, etc. in taking in or emitting air; the pulsations of a gasbag or envelope in this action.

breathing stress. Any stress produced in an airship by its breathing.

brennschluss, noun. [German, "combustion termination."] The cessation of burning in a rocket, resulting from consumption of the propellants, from deliberate shut-off, or from other cause; the time at which this cessation occurs. See BURNOUT, CUT-OFF.

bridle, noun. Specif., a line or sling branching out into two or more ends used, e. g., to distribute a load applied through a single line over two or more points or to reduce yaw in towing or mooring.

brief, verb tr. Specif., to instruct (aircrew members or passengers) before a flight with information or directions regarding the route to be followed, weather conditions, procedures to be observed, or any other subject of special interest or concern to a particular flight or mission.

—briefing, *noun*.

broadside array. An antenna arrangement having its direction of maximum radiation perpendicular to the axis or plane of the array.

B-scope, noun. A type of radarscope that presents the range of an object by a vertical deflection of the signal on the

screen and bearing by a horizontal deflection.

bubble canopy. A cockpit canopy consisting of a single molded form of clear plastic protruding like a bubble from the airplane fuselage.

bubble horizon. *Nav.* A circle on the celestial sphere formed by the plane established by a bubble sextant intersecting the sphere; also, the plane established by a bubble sextant.

The bubble horizon is parallel to the celestial horizon. See CELESTIAL HORIZON and note.

bucket, noun. 1. A turbine blade. 2. Any of the cups on the rim of an air-driven gyroscope rotor.

bucket height. The blade height of a turbine bucket. See BLADE HEIGHT.

bucket seat. 1. A kind of small seat or stationary chair (sometimes tilting or swiveling), often used aboard aircraft for crew members, having a curved back and rather suggesting a bucket with most of the side sliced away. 2. One of the depressions designed to receive the buttocks in a kind of bench sometimes fitted aboard aircraft.

bucket wheel. Same as TURBINE WHEEL.

Rare.

buckle, verb intr. Of a plate, beam, column, etc.: To bend out of its own plane or axis under compression. Cf. WRINKLE.

—buckling, *noun.*

buffer zone. An airspace safety zone established between adjacent traffic lanes or holding patterns, or between a traffic lane and a holding pattern.

buffet boundary. A flight boundary expressed in terms of lift coefficient and speed beyond which buffeting occurs; a graphic representation of these limiting conditions, shown as a curve plotted with lift coefficient and Mach number as co-ordinates.

buffeting, noun. The beating of an aircraft's structure or surfaces by unsteady flow, gusts, etc.; also, the irregular shaking or oscillation of an aircraft component owing to turbulent air or to separated flow. Cf. FLUTTER.

bulkhead, noun. A wall, partition, or similar member or structure in an airplane fuselage, a seaplane float or hull, an airship hull, etc., at right angles to the longitudinal axis of the body, and serving to strengthen, divide, or help give shape to the body.

In a seaplane float or in the bottom of a seaplane hull, bulkheads are used to make watertight compartments. In the hull of a rigid airship, cross-wired transverse frames between the gasbags are termed "bulkheads."

bullet, noun. In a jet engine, a pointed, bullet-shaped part in the exhaust end of the engine, which may be moved back and forth to vary the cross-sectional area of the jet orifice.

bump, noun. 1. An AIR BUMP. 2. A curved or rounded projection, rise, or projecting part used in the bump method of testing or experimenting. See BUMP METHOD.

bump, verb tr. To fire (a rocket) from a booster rocket at altitude. See BOOSTER ROCKET, sense 2.

bump method. A method of aerodynamic testing or experimenting in which the model or other object is mounted in a wind tunnel on a bump (which see, sense 2) designed to increase the velocity of flow.

bungee, noun. A spring, elastic cord, or other tension device used, e. g., in a control system on an aircraft to balance an opposing force or in a landing gear to assist in retracting the gear or to absorb shock, etc.

buoyancy, noun. 1. The property of floating on or in a fluid. 2. The upward force exerted on a body, such as a lighter-than-air aircraft or a seaplane float or hull, by the fluid it displaces. 3. The amount of this force, expressed in units of weight and equal to the weight of the fluid displaced by a body. 4. The force on a body in any direction, ascribable only to the pressure gradient acting in that direction.

See AEROSTATIC LIFT, CENTER OF BUOYANCY, EXCESS BUOYANCY.

buoyancy equilibrium. The condition in which the buoyancy of a lighter-than-air aircraft exactly supports its weight.

burble, noun. A separation or breakdown of the streamline flow past a body; the eddying or turbulent flow resulting from this.

Burble occurs, e. g., over a wing operating at an angle of attack greater than the angle of maximum lift, resulting in a loss of lift and an increase of drag. See COMPRESSIBILITY BURBLE.

burble angle. The angle of attack at which burble sets in. See CRITICAL ANGLE OF ATTACK.

burble point. A point reached in an increasing angle of attack at which burble begins; burble angle.

burner, noun. A combustion chamber. See COMBUSTION CHAMBER and note.

burner basket. A descriptive term sometimes applied to a flame tube, esp. when much-perforated and somewhat resembling a basket.

burnout, noun. 1. An act or instance of the end of fuel and oxidant burning in a rocket; the time at which this burnout occurs. Cf. BRENNSCHLUSS, CUT-OFF. 2. An act or instance of something burning out or of overheating; specif., an act or instance of a rocket combustion chamber, nozzle, or other part overheating so as to result in damage or destruction.

burnout velocity, or burnt velocity. The velocity of a rocket missile, rocket-powered aircraft, or the like at burnout.

burst disk. A diaphragm designed to burst at a predetermined pressure differential; sometimes used as a valve, e. g., in a liquid-propellant line in a rocket. Also called a "rupture disk."

Busemann biplane. [After Adolf Busemann (1901-), German-born American engineer.] A design or configuration of two superposed airfoils of such cross-sectional shape and placement as to eliminate drag due to thickness of the airfoils at supersonic speeds.

bush pilot. A pilot that regularly flies in wild, desolate, or relatively unsettled country, as in parts of Canada or Alaska, esp. without benefit of ground navigational aids, well-prepared airfields, etc.

butterfly tail. An airplane tail assembly in which the surfaces are set at a pronounced positive dihedral (e. g., 45°),

forming a V. Also called a "V-tail." See RUDDERVATOR and note.

buttock line. *Lofting.* An edge view of a fore-and-aft vertical plane passed through an aircraft fuselage or hull. The term is taken from shipbuilding.

butt rib. A compression rib at the root of an airfoil, or at the point of attachment to the center section of a wing. Also called a "root rib."

A butt rib may or may not have the profile or contour of the airfoil.

buzz, noun. A rapid vibration or oscillation of a structure or body; the noise resulting from this.

Buzz may occur, e. g., in an air diffuser from alternately swallowing and expelling upstream a normal shock system; in a rocket engine, it may occur as a result of unstable combustion. In the latter case it is sometimes specified as an oscillation or vibration of the order of about 10 to 50 cycles per second. See AILERON BUZZ.

buzz, verb. 1. *tr.* To fly low over or to dive at in an airplane under power, sometimes for the purpose of attracting attention or of making a close observation. 2. *intr.* To vibrate or oscillate rapidly, making a humming noise.

buzzing, noun. The action of the verb buzz; BUZZ.

bypass engine. A jet engine, esp. one of the gas-turbine type, in which part of the air taken in by the engine is passed around the combustion chamber or chambers to augment the gases of combustion in the jet stream. The term ordinarily refers to a jet engine incorporating a low-pressure compressor forward of a high-pressure compressor, the air being diverted after passing through the forward compressor. The type is sometimes ambiguously termed a "ducted fan" (which see, sense 2).

cab, noun. A cabin or nacelle housing the flight crew on an aircraft.

cabane, noun. [French "cabin."] A pyramidal arrangement of struts used, e. g., to support a wing above the fuselage of an airplane or to provide a point of attachment for the inner ends of the half-axes in some types of landing gear. On earlier airplanes, one or more cabanes were sometimes mounted on or above the upper surface of a wing and in conjunction with bracing wires supported the wing from above.

cabane strut. A strut used in a cabane.

cabin, noun. An enclosed compartment in an aircraft for members of the crew, or for passengers or cargo. A canopy-covered cockpit is sometimes, though not usually, called a "cabin."

cabin altitude. The simulated altitude condition in a pressurized aircraft cabin. See ALTITUDE, sense 3.

cabin pressurization. The production in an aircraft cabin of air pressure higher than the ambient pressure.

cabin supercharging. Cabin pressurization. *Popular.*

"Cabin pressurization" (which see) is the more appropriate term.

gage, verb tr. To lock (a gyroscope) in a fixed position in its case.

calibrated airspeed. An airspeed value derived when corrections have been applied to an indicated airspeed to compensate for installation errors, instrument errors, errors in the pitot-static system, and errors induced by the attitude of the aircraft, or, alternatively, an airspeed value found by applying corrections to a basic airspeed for errors in the pitot-static system and errors induced by aircraft attitude.

calibrated altitude. Altitude as determined by the application of corrections for static-pressure error, installation error, and instrument error to the indicated altitude shown by a pressure altimeter. See INDICATED ALTITUDE.

calibration card. A card that gives the corrections necessary to apply to an airspeed or altitude reading or value to determine calibrated airspeed or altitude.

camber, noun. 1. The curvature of the mean line of an airfoil or airfoil section from leading edge to trailing edge; the amount of this curvature, expressed as the ratio of the maximum departure of the curve from the chord to the chord length. 2. *Specif., same as MEAN CAMBER.*

Camber is considered positive when the departure of the curve is upward from the chord, negative when downward. See CONICAL CAMBER, LOWER CAMBER, UPPER CAMBER.

cam engine. A type of reciprocating engine in which the pistons operate against a shaft-mounted cam, rather than against a crankshaft.

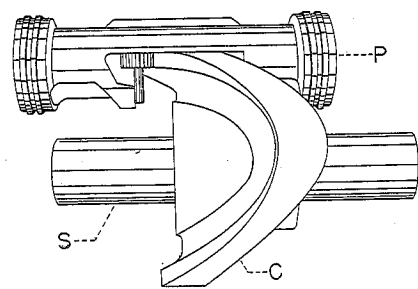

Cam engine. Double-acting piston P (one of several) working on cam C to turn shaft S.

Campini engine. [After Secondo Campini (1904-), Italian engineer.] An early type of jet engine consisting essentially of an air intake, a compressor driven by a reciprocating engine, a burner, and an exhaust nozzle. This engine was flown in Italian Caproni aircraft during 1940-41.

can, noun. 1. On a gas-turbine engine, any one of a number of individual combustion chambers, each consisting principally of an outer shell or cover surrounding an inner liner, or flame tube. These cans are usually mounted in a ring or annulus entirely surrounding the main shaft of the engine. See MULTIPLE COMBUSTION CHAMBER. 2. Also applied to a flame tube, when mounted with others in an annulus and enclosed in a common shroud. See CANNULAR COMBUSTION CHAMBER.

canard, noun. An aircraft or aircraft configuration having its horizontal stabilizing and control surfaces in front of the wing or wings.

cannular combustion chamber. A combustion chamber of a gas-turbine engine consisting of an annulus of flame tubes—here called "cans"—enclosed within a common shroud or cover. See CAN, sense 2 and cf. MULTIPLE COMBUSTION CHAMBER.

canopy, noun. A covering or something likened to a cover. See COCKPIT CANOPY, PARACHUTE CANOPY.

canted deck. An aircraft-carrier flight deck having part of its area skewed to the center line of the ship, i. e., part of the deck area juts to one side.

The canted deck increases the usable landing area of the carrier and permits planes to be parked out of the way of landing airplanes.

cantilever, noun. A beam or member supported at or near one end only, without external bracing.

This word is used to designate aircraft components so constructed or mounted, as in cantilever tail plane, cantilever wing, or to designate airplanes having cantilever wings, as in cantilever monoplane. See FULL-CANTILEVER and SEMICANTILEVER.

capacitance altimeter. An experimental type of low-altitude altimeter that utilizes the capacitance between the aircraft and the ground below to measure absolute altitude.

capstrip, noun. Also cap strip. A strip or flange around the edge of a wing rib or the like. See CHORD, sense 5.

capsule, noun. A boxlike component or unit, often sealed. See ANEROID, noun and adj., and EJECTION CAPSULE.

captain, noun. A name applied to the pilot of an aircraft, as disting. from the copilot or other crew members—used esp. in commercial aviation.

captive balloon. A balloon, usually a kite balloon, which in use is moored by cable to the ground, to a ship, etc. Used chiefly for military observation or for anti-aircraft defense. See BALLOON, noun, and note, BARRAGE BALLOON.

captive helicopter. A helicopter tethered by a cable to permit limited ascent only, as in testing.

car, noun. The structure attached to, or suspended from, a balloon or airship for carrying crew members, passengers, cargo, or equipment, or for housing an engine.

See BASKET, sense 1, CONTROL CAR, GONDOLA, POWER CAR, SIDE CAR, SUBCLOUD CAR.

carbon jet vane. A vane made of carbon (for its heat-resistant qualities) and used in a jet stream. See JET VANE.

carburetor adapter. A piece or part used to attach a carburetor to a supercharger, and through which the mixture passes from the carburetor to the supercharger.

card compass. A compass using as the direction indicator a pivoted dial or wheel equipped with magnetic sensing elements.

cardinal heading. A heading toward one of the cardinal points of the compass, i. e., north, south, east, or west.

cargo, noun. The freight shipped, or consigned for shipment, aboard an aircraft or vessel—disting. from passengers, and sometimes disting. from mail.

cargo parachute. A parachute designed for dropping cargo from aircraft.

Carnot cycle. [Pronounced "car-no" (accent on last syllable). After N. L. S. Carnot (1796-1832), French scientist.] An ideal cycle of operations for heat engines consisting of an adiabatic compression, isothermal addition of heat, adiabatic expansion, and isothermal rejection of heat back to the original condition.

carrier, noun. In specific senses: 1. An AIRCRAFT CARRIER. 2. A person or organization, esp., a commercial organization, that carries freight or people

by air; also, an aircraft used for this purpose. See AIR CARRIER, senses 1 and 2.

Compounds in sense 1 (all self-explanatory) include: carrier-based, adj., carrier fighter, carrier landing, carrier squadron, carrier take-off.

carrier aircraft. 1. An aircraft, esp. a fixed-wing airplane, that is carried aboard, and operates from, an aircraft carrier. Carrier aircraft (i. e., carrier planes), are specially designed and equipped for the purpose, as with folding wings, arresting hooks, etc. 2. An aircraft that carries something, esp. an aircraft that carries another aircraft, a large guided missile, or the like. See COMPOSITE AIRCRAFT, sense 1, and cf. MOTHER AIRCRAFT. 3. *Collective* (in sense 1 or sense 2) as, ten carrier aircraft.

carrier-controlled approach. An approach controlled by an aircraft-carrier control system in which radar is used to determine the position of landing airplanes and the resultant information is sent by radio to the aircraft for use in making approaches; the equipment used in this system.

cartridge starter. An engine starter operated by a blank cartridge. Also called a "combustion starter."

cartwheel, noun. Same as VERTICAL REVERSEMENT.

cascade, noun. 1. A lattice or row of vanes or airfoils, e. g., a lattice of vanes used to straighten flow in a wind tunnel. 2. A series or succession of like airfoil or blade profiles representing successive rows of compressor blades, a rotating propeller, etc.

caster, verb intr. Of a wheel: To swivel about an eccentric vertical axis.

—castered, adj., castering, adj.

castor, verb intr. Variant of "caster."

catapult, noun. A power-actuated machine or device for hurling forth something, as an airplane or guided missile, at a high initial speed; also, a device, usually explosive, for ejecting a person from an aircraft.

Cf. LAUNCHER, senses 1 and 2.

catapult, verb tr. To fling forth; to discharge from a catapult.

catapult point. A point, specially reinforced, on an airplane, missile, or the like where it engages with the catapult mechanism.

catenary, noun. 1. The curve assumed by a chain, heavy cord, or the like hanging between two points of support; something having this shape. 2. A CATENARY CURTAIN.

catenary curtain. On an airship, a fabric strip or panel fastened along one edge to the airship's envelope and having the other edge scalloped or stretched in a series of catenaries, used to distribute the load of the car on the envelope by lines leading from the car to the points made by the catenaries. Catenary curtains are installed both inside and outside the main envelope.

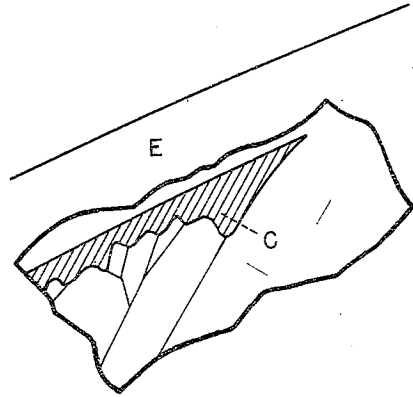

Catenary curtain. Airship envelope E cut away to show interior catenary curtain C.

cathedral, noun. [Greek *kathodos* ("descent"), from *kata* ("down") + *diedral*.] Same as ANHEDRAL.

cathode-ray tube. A sealed, evacuated bulb or tube, roughly funnel-shaped, in which an electron beam, striking a fluorescent screen at the large end of the tube, is modulated in intensity or position to show the value of the received voltage or current. The cathode-ray tube is used, e. g., for visual presentation in radar and television receivers.

catwalk, noun. Any narrow footway on or in an aircraft, as along a wing root, beside a bomb bay, etc.

CAVU—Abbreviation for *ceiling and visibility unlimited*—pronounced as a word and also used as a noun or adjective, as, to have CAVU, or as in CAVU weather.

ceiling, noun. 1. The maximum height attainable by an aircraft or airborne vehicle under given conditions and at which it can perform effectively;

specif., ABSOLUTE CEILING. See also BALLONET CEILING, HOVERING CEILING, SERVICE CEILING, STATIC CEILING. 2. The capability of an aircraft or airborne vehicle to attain height, as, a plane with a poor ceiling. 3. The maximum height at which a component, piece of equipment, or system, such as an aircraft engine, can perform effectively under given conditions. 4. An overcast of clouds, dust, or the like above a given area; the height of the lower surface of a cloud overcast.

ceiling balloon. *Meteorol.* A small free balloon having a known rate of ascent, released to find the height of a cloud ceiling. The timing of the balloon's ascent is stopped when the balloon is obscured by the cloud.

ceiling-height indicator. A kind of clinometer used to measure the height of a cloud ceiling with the aid of a ceiling projector.

ceiling light. Same as CEILING PROJECTOR.

ceiling projector. A light that projects a spot on the underside of a cloud ceiling to enable the determination of the height of the ceiling with a ceiling-height indicator.

ceilometer, noun. A device or apparatus for measuring the height of a cloud ceiling. See ROTATING-BEAM CEILOMETER.

celestial fix. A fix or position obtained through observation and altitude measurements of celestial bodies.

celestial guidance. The guidance of a missile by means of instruments and devices which automatically sight preselected celestial bodies, calculate positions, and direct the missile along a predetermined flight path. Sometimes called "stellar guidance."

celestial horizon. The great circle on the celestial sphere formed by the intersection of the sphere with a plane passing through the center of the earth perpendicular to the zenith-nadir axis of an observer; also, the plane that establishes this horizon.

The celestial horizon and the bubble horizon of a sextant are considered identical when the sextant is sighted on bodies at great distances, or at distances considered infinite.

celestial navigation. Navigation in which geographical position is found by reference to celestial bodies.

celestial sphere. An imaginary sphere of infinite radius, whose center coin-

cides with the center of the earth and having an equator, meridians, and poles that are projections of the earth's. Celestial bodies are assumed to lie on the surface of this sphere.

cell, noun. a. A boxlike unit; a compartment. See FUEL CELL, GAS CELL. b. A boxlike structure or truss. See WING CELL.

cellule, noun. [Literally, a "little cell."] A somewhat inappropriate term for a cell, esp. a wing cell.

center line. Also *centerline, noun.* 1. A line, real or imaginary, through the center of something, as an airplane fuselage or hull, an airship hull, a runway, a rocket, etc. 2. On a certain type of parachute, one of the lines running to the apex of the canopy to maintain a flat canopy top. 3. *Aerial Photography.* A line drawn from the center point of a vertical aerial photograph to the transposed center point from an overlapping photograph, showing the track of the photographing aircraft.

center of buoyancy. The center of gravity of the fluid displaced by a body floating on, or suspended in, the fluid. With a balloon or airship, it is approximately the same point as the center of gravity of the contained gas.

center of pressure. The point at which the chord of an airfoil section (prolonged if necessary) intersects the line of action of the resultant aerodynamic forces, and about which the pressures balance.

center-of-pressure coefficient. A coefficient expressing the ratio of the distance of a center of pressure aft of the leading edge of an airfoil section to the chord length.

center-of-pressure travel. The movement of the center of pressure of an airfoil along the chord with changing angle of attack; the amount of this movement, expressed in percentages of the chord length from the leading edge.

center of thrust. A line coincident with the center line of a propeller shaft, about which the thrust forces are balanced. Cf. THRUST AXIS.

center point. *Aerial Photography.* A point at the center of an aerial photograph, corresponding in position to the

interception of the camera axis with the plane of the image.

center section. The middle or central section of an airplane wing, to which the outer wing panels are attached. Where a wing has no clearly defined center section, the center section is considered to lie between points of attachment of the wing to the fuselage or fuselage struts.

centrifugal compressor. A compressor having one or more vaned rotary impellers which accelerate the incoming fluid radially outward into a diffuser, compressing by centrifugal force. Sometimes called a *centrifugal-flow compressor*. Cf. AXIAL-FLOW COMPRESSOR.

centrifugal-flow engine. A gas-turbine engine having a centrifugal compressor.

—centrifugal-flow gas-turbine engine, centrifugal-flow turbojet, centrifugal-flow turbo-prop. See GAS-TURBINE ENGINE.

centrifugal supercharger. A centrifugal compressor used to increase the quantity of air inducted into a reciprocating engine.

centrifugal tachometer. A type of tachometer that utilizes fly weights whirled outward by centrifugal force from a shaft mechanically driven by the engine.

centrifuge, noun. 1. A machine for separating substances from one another by centrifugal force, as for separating sludge from oil in a given sample. 2. A machine utilizing centrifugal force to create an artificial gravity, used, e. g., to test the tolerance of flyers to high gravitational forces.

ceramal, noun. [*Ceramic+alloy*.] Also *ceramel*. [*Ceramic+metal*.] Same as CERMET.

ceramic liner. A heat-resistant liner made of ceramic materials fired to a high temperature, installed, e. g., in the combustion chamber or nozzle of a rocket or jet engine.

cermet, noun. [*Ceramic+metal*.] A material formed by a mixture of ceramic and metal substances, such as titanium carbide and chromium. Also called a "ceramal" or "ceramel."

cetane number. A number indicating the relative ignitability of a fuel oil for compression-ignition engines.

chain reaction. A progressive or self-propagating reaction, e. g., a chemical or nuclear reaction, in which one reaction leads to another of the same kind.

challenge, noun. Radar. Same as INTERROGATION.

chamber, noun. A compartment, cell, bottle-like object, or a distinct hollow section or part of something.

See ALTITUDE CHAMBER, COMBUSTION CHAMBER, OUTER CHAMBER, SETTLING CHAMBER, TEST CHAMBER.

chamber ascent. A simulated ascent in an altitude chamber.

chandelle, noun. A performance or maneuver in which an airplane makes an abrupt, steep climbing turn using its momentum for a faster rate of climb, gaining altitude and reversing its direction of flight simultaneously. It is a form of reversal (which see).

—chandelle, verb intr. To make a chandelle.

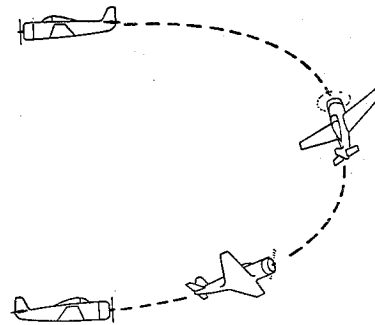

Chandelle.

channel, noun. 1. A band of radio frequencies wide enough to allow transmission without interference from transmissions on adjacent bands. 2. A circuit or path for electrical transmission.

channel-wing airplane. A type of airplane having portions of the wings formed in half circles (as seen from the front or rear), in which the propellers are mounted at the trailing edge, drawing the air through the channels for the purpose of permitting short take-off and landing.

characteristic, noun. Specif., a distinguishing quality, property, feature, or capability of a machine or piece of equipment, or of a component part.

The characteristics of an aircraft are (1) qualities such as stability, maneuverability, and strength; (2) features such as number,

kind, or power of engines, and size, shape, or number of wings; and (3) capabilities such as range, speed, and payload. See AIRFOIL CHARACTERISTIC, FLIGHT CHARACTERISTIC, PERFORMANCE CHARACTERISTIC.

characteristic chamber length. The length of a straight cylindrical tube having the same volume as the minimum chamber volume of a rocket engine that will permit complete combustion of a given propellant combination.

characteristic velocity. A measure of the effectiveness with which the chemical reaction of the propellants in a rocket motor produce the high-temperature, high-pressure exhaust gases. Numerically equal to the product of the combustion-chamber pressure and the nozzle throat area divided by the rate of propellant mass flow.

charge, noun. Specif., the fuel-air mixture introduced into the cylinder of a piston engine.

chart, noun. A map intended for use in marine or air navigation; specif., an AERONAUTICAL CHART.

chase pilot. A pilot who flies along in an airplane advising a pilot who is making a check, training, or research flight in a nearby airplane. Cf. SAFETY PILOT, sense 1.

chassis, noun. The landing gear assembly or structure of an airplane, consisting of struts, wheels, floats, skids, axles, etc. Rare.

chatter, noun. A repeated and rapid bouncing or striking together of two or more objects or parts; the noise made in this action.

check, verb. To check out. 1. tr. To give a check flight to, as, to check a pilot out. 2. intr. To make a check flight, as, to check out on a jet airplane. See CHECK FLIGHT, sense 2.

check flight. 1. A flight made to check or test the performance of an aircraft or of a piece of equipment or component, or to obtain measurements or other data on performance; a TEST FLIGHT. 2. A familiarization flight in an aircraft, or a flight in which a pilot or other aircrew member or members are tested or examined for proficiency. Cf. PROFICIENCY FLIGHT.

check list. A list carried in an airplane listing things requiring attention for different operations, such as preflight operations, take-off, landing, etc.

check-off list. A Navy term for "check list."

check-out, noun. An act or instance of checking out; the test or examination made of a person or piece of equipment in a check flight.

check pattern. A specified flight pattern to be followed in making a check flight.

check pilot. 1. A pilot who tests or proves the performance of an aircraft; a TEST PILOT. 2. A pilot who tests or examines another pilot on a check flight.

check point. A known geographical point used to ascertain the position of an aircraft; a LANDMARK.

check stop. Same as LIMIT STOP. Popular.

chemical engine. An engine, esp. a jet engine, that uses chemical fuels. Sometimes applied to an engine that uses chemical fuels other than hydrocarbon fuels.

chemical pressurization. The pressurization of propellant tanks in a rocket by means of high-pressure gases developed by the combustion of a fuel and oxidant or by the decomposition of a substance.

chemopause, noun. The upper boundary of the chemosphere.

chemosphere, noun. A layer or region of the earth's atmosphere in which significant photochemical reactions occur, considered to begin about 20 miles above the earth's surface and to extend to a height of about 50 miles.

chest-pack parachute. A parachute or parachute pack, commonly used as a reserve parachute, attached to the front of the harness and carried on the chest.

chest-to-back acceleration. Av. med. Accelerating force acting on the human body in the direction from the chest to the back, as occurs when seated facing forward in an aircraft slowing down. It is a type of transverse acceleration. See TRANSVERSE ACCELERATION.

chin, noun. A place or area immediately beneath and slightly behind the nose of certain fuselages or nacelles, likened to the human chin.

Self-explanatory compounds include chin radiator, chin turret.

chine, noun. The corner or edge where the bottom of a seaplane hull or float joins the side or deck.

484035-59-4

chine flare. A flare of the bottom or side of a seaplane float or hull, as seen in transverse section, when the bottom or side has a concavity terminating at the chine.

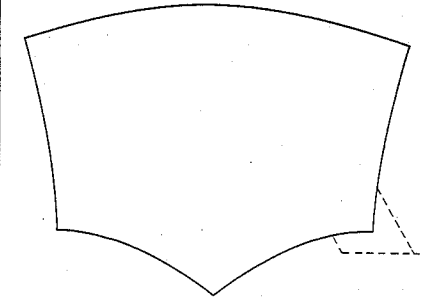

F chine flare, side and bottom.

chock, noun. A block, wedge, or other obstruction placed against an aircraft's wheel to prevent rolling.

—chock, verb tr. To block with chocks.

choked flow. Flow in a duct or passage such that the flow upstream of a certain critical section cannot be increased by a reduction of downstream pressure.

chokes, noun. A form of altitude sickness characterized by coughing, a deep and usually burning irritation in the lungs, and shallow breathing.

choking Mach number. The Mach number at some reference point in a duct or passage (e. g., at the inlet) at which the flow in the passage becomes choked. See CHOKED FLOW.

chopper, noun. A helicopter. Slang.

chord, noun. 1. A straight line intersecting a circle or other curve, or a straight line connecting the ends of an arc; specif., the segment of a straight line between its two points of intersection of a circle or other curve. 2. In aeronautics, a straight line intersecting or touching an airfoil profile at two points; specif., that part of such a line between two points of intersection. This line is usually a datum line joining the leading and trailing edges of an airfoil, joining the ends of the mean line of an airfoil profile, or running along the lower surface or line of an airfoil profile, from which the ordinates and angles of the airfoil are measured. As such a datum line, it is sometimes called the "geometric chord," to distinguish it from a chord established on the basis of any other

considerations. 3. The dimension of an airfoil or airfoil section from leading to trailing edge; **CHORD LENGTH**. 4. [Perhaps suggested or influenced by sense 3.] Width (of an airfoil), as, a wing of narrow *chord*. 5. *Engineering*. In a beam, girder, or the like, a flange, cap, or similar feature approximately perpendicular to, or crossing, the web and running the length of the member, e. g., either flange of an I-beam, or the capstrip of a wing rib; a **CHORD MEMBER**.

In sense 3, points or stations along a chord are designated in percentages or fractions of the chord or chord length from the leading edge, as, a point at 25 percent, or (one) quarter, *chord*.

See EQUIVALENT BLADE CHORD, GEOMETRIC CHORD, MEAN AERODYNAMIC CHORD, MEAN GEOMETRIC CHORD, ZERO-LIFT CHORD.

chord direction. The direction parallel to a selected chord.

chord length. The length of the chord of an airfoil section between the extremities of the section.

For many airfoils, the chord is established intersecting the airfoil profile at its extremities, and the chord length is equal to the length of the chord between the points of intersection; for airfoils where the chord is established by a point or points of tangency or intersection not at the extremities, however, the chord length is considered to extend beyond either or both points, as necessary, to equal the maximum length of the profile. See **CHORD**, senses 2 and 3.

chord member. A rigid longitudinal member in a truss.

chordwise, adj. Moving, located, or directed along the chord, as in *chordwise axis*, *chordwise distribution*.

chordwise, adv. Along the chord, or in the direction of the chord, as, to mount (something) *chordwise*.

chronometric tachometer. A type of shaft-driven tachometer utilizing an escapement similar to that used in clocks and watches.

chugging, noun. A form of combustion instability, esp. in a liquid-propellant rocket engine, characterized by a pulsing operation at a fairly low frequency, sometimes defined as occurring between particular frequency limits; the noise made in this kind of combustion.

chute, or 'chute, noun. A clipped form of the word "parachute." *Popular*.

chute boot. Same as **PARACHUTE BOOT**. *Popular*.

circle, verb tr. To fly in a circle around, as, to *circle* a field.—*intr.* To fly in a circle.

circle marker. A circular band or mark at the approximate center of a landing area or at the intersection of the principal runways of an airfield.

circle of equal altitude. *Nav.* A circle from any point of which the angular altitude of a given celestial body is the same. Two overlapping circles of equal altitude provide a fix, with the aid of dead reckoning, at one of the two points where the circles intersect. Also called a **circle of position**.

circular-arc airfoil. An airfoil profile whose curved sides are circular arcs.

circular scanning. Radar scanning in which the radio-frequency beam sweeps around in a circle.

circulation, noun. 1. In aerodynamics, a hypothetical circulation of fluid about a body, such as an airfoil, used in mathematical explanations of the theory of lift; technically, the line integral along a closed curve of the velocity resolved along that curve.

Circulation is demonstrated by the reaction of a rotating cylinder immersed in a moving fluid with its axis perpendicular to the direction of flow. The rotation of the cylinder, because of the viscosity of the fluid, causes an increase in the velocity of the flow past one side of the cylinder, and a decrease in velocity past the other side where the rotation is against the direction of flow; this difference produces a pulling force acting on the cylinder on the side of increased velocity, that is, of decreased pressure. (See **BERNOULLI'S LAW**.) (A practical application of this phenomenon—known as the "Magnus effect"—was made by Flettner's rotor ship, a wind-driven vessel which used upright cylinders rotating in the air for propulsion.) An airfoil or similar body in motion relative to the air creates flow patterns analogous to those around the rotating cylinder, and experiences a resultant lift analogous to the cross-fluid force experienced by the cylinder. See **LIFT**, sense 1 and note.

circulatory flow. Flow that circulates; circulation (which see).

civil airway. An airway maintained and controlled by civil authority, or one designated or approved by civil authority as suitable for domestic or foreign air commerce.

civil twilight. For computation purposes, the period during which the sun is between the horizon and a point 6° below the horizon (this point being measured at the center of the sun's disk), morning or evening.

clamshell, adj. Opening along a median line and swinging apart like a clam-

shell, as in *clamshell doors*, *clamshell canopy*, *clamshell shutter*. See **EYELID**.
Clark Y airfoil. [After Col. Virginius Evans Clark (1886-1948), American soldier and engineer.] A particular type of airfoil profile characterized esp. by a flat lower surface, much-used for wings and propellers.

clean, adj. 1. Free from bulky or pronounced bulges or protuberances; free of fixed external encumbrances; shapely; well streamlined—said of a fuselage, an airplane, etc. 2. Of an airplane, flaps and landing gear retracted.

clear, verb tr. To give a clearance to. See **CLEARANCE**.

clear-air turbulence. Turbulence that occurs in clear air and not associated with cloud formation, such as that associated with winds at low altitudes and with the jet stream at high altitudes.

clearance, noun. An authorization, verbal or otherwise, to depart from an airport or airfield or to fly a given route under specified conditions; a form granting such authorization.

An IFR clearance authorizes flight under instrument conditions; a VFR clearance authorizes flight under visual conditions. See **AIR TRAFFIC CLEARANCE**.

clearance limit. The point to which an aircraft is authorized to proceed under an air traffic clearance. The clearance limit is ordinarily either the point of intended landing, a reporting or holding point, or a point at the boundary of the controlled airspace.

cleared area. Any area cleared of trees, structures, or other obstructions to the take-off, flight, or landing of aircraft; specif., an **OVERRUN** (in sense 2).

clear ice. Same as **GLAZE**.

climb, noun. 1. The action of an aircraft, rocket, or the like ascending, as, the power required during *climb*. 2. The vertical distance covered during this action, as, the amount of *climb*. 3. The capability of an aircraft, etc. as measured or judged by its action of climbing, or by its rate of climb, as, a plane with better *climb*. 4. A rate of climb, as, a *climb* of 1000 fpm. 5. An ascending flight path, as, to enter a *climb*; to guide a missile along a *climb*; a steep *climb*.

Self-explanatory compounds include: **climb attitude**, **climb capability**, **climb characteristic**, **climb performance**, **climb velocity**.

climb, verb intr. To ascend or go upward—said of aircraft, rockets, etc., or of persons within. See **ASCEND**.

climb-cruise method. A method of cruise control with jet airplanes in which airspeed is held constant, resulting in a gradual climb throughout the cruise as the airplane loses weight through fuel consumption.

climb indicator. Same as **RATE-OF-CLIMB INDICATOR**.

climbout, noun. The climb made directly after take-off.

clinometer, noun. Any of various instruments for measuring angles of slope, inclination, elevation, or the like, such as the angle between the horizontal and the line of sight to the spot of light thrown by a ceiling projector, or between the horizontal and a ship's axis; also, an **INCLINOMETER**.

clipped wing. A wing having its tip or tips more or less squared off (as seen in planform). Said esp. of a conventional wing or of a delta wing (**clipped delta**, or **clipped delta wing**).

clock, noun. The visible area extending horizontally all around an aircraft, as, attackers approached from all parts of the *clock*—also used in the contracted phrase **o'clock** to indicate direction relative to the aircraft, as in 12 *o'clock*, the direction dead ahead; 3 *o'clock*, the starboard direction perpendicular to the longitudinal axis; 6 *o'clock* high, the direction directly to the rear and above; etc.

closed-center system. A hydraulic system in which pressure is maintained when the selector valves are in neutral and no hydraulic units are in operation. Cf. **OPEN-CENTER SYSTEM**.

closed-circuit flight. A nonstop round-trip flight.

closed-circuit wind tunnel. A wind tunnel in which the air or other gas is recirculated. Also called a "return-flow wind tunnel." Cf. **OPEN-CIRCUIT WIND TUNNEL**.

closed course. A circuit around ground markers which airplanes are required to follow in a race or speed run.

closed-cycle engine. A gas-turbine engine in which the same working gas is circulated again and again, being compressed, heated by an external source, expanded through a turbine, and

cooled, then repeating the process. Cf. OPEN-CYCLE ENGINE.

closed-jet wind tunnel. Same as CLOSED-THROAT WIND TUNNEL.

closed-throat wind tunnel. A wind tunnel in which the test section is enclosed by the tunnel walls. Cf. OPEN-THROAT WIND TUNNEL.

cloud base. The lower surface of a cloud.

cloud deck. The upper surface of a cloud.

club propeller. A heavy, short-bladed propeller used to load an engine during testing on a test stand. Also called a "test club."

clutter, noun. A jumble of unwanted radar returns on a radarscope, interfering with observation of the desired signals.

co-altitude, noun. *Nav.* The complement of the angular altitude of a body, i. e., zenith distance expressed in degrees. See ZENITH DISTANCE, note.

coaxial helicopter. A helicopter having two rotors mounted on coincident axes. The rotors turn in opposite directions to neutralize torque.

cockpit, noun. 1. A cutout or space in the top of an airplane fuselage for the pilot, other aircrew members, or passengers, likened to a pit for fighting cocks. It may or may not be protected by a canopy. 2. By extension, a compartment or cabin, or other space set apart in an aircraft for the pilot and also for the copilot, if any.

cockpit capsule. Same as EJECTION CAPSULE.

cockpit canopy. A transparent cover for a cockpit. See BUBBLE CANOPY.

cockpit check. 1. An inspection of the instruments, etc. in the cockpit for proper functioning, usually made just prior to taking off. 2. A brief course of instruction given a pilot in the cockpit to familiarize him with the instruments, controls, etc.

cockpit combing. A padded lining around the rim of a cockpit.

cockpit control. A controlling lever, wheel, or other device in the cockpit of an airplane, such as the control stick or the rudder bar.

code beacon. A beacon that flashes a characteristic signal by which it may be recognized. A code beacon is used, e. g., to identify a particular airport.

co-declination, noun. The complement of the declination of a body, i. e., polar distance when declination and latitude have the same name. See POLAR DISTANCE.

coke-bottle fuselage. A fuselage having a pinched-in waist, similar in appearance to the familiar soft-drink bottle. *Popular.*

Dietrich Küchemann designed such a fuselage during WW II, based on flow studies at the wing-fuselage juncture of a swept-wing airplane. The application of the "area rule" (which see) may, but does not necessarily, result in a similar configuration.

co-latitude, noun. The complement of the terrestrial latitude of an observer, i. e., the arc of the observer's celestial meridian between the elevated pole and the zenith.

coileopter, noun. [Greek *koleopteros* ("sheath-winged").] An aircraft having an annular (i. e., barrel-shaped) wing, the engine and body being mounted within the circle of the wing. The aircraft is designed to take off and land vertically. See ANNULAR AIRFOIL.

collective pitch control. On a rotary-wing aircraft, a control for changing the blade angle of all the rotor blades simultaneously; the control exercised through this mechanism.

collector ring. 1. A ring-shaped duct for collecting gases. See EXHAUST COLLECTOR RING. 2. A conducting ring from which electrical current is taken or to which it is delivered.

collision course. The course taken by an aircraft, missile, etc., which if maintained will cause it to collide with another aircraft, etc.

column, noun. *Specif.,* a CONTROL COLUMN.

comb, noun. A device likened to a common hair comb, such as a pressure-measuring rake (see RAKE, sense 1) or a certain kind of spoiler.

combustion chamber. Any chamber for the combustion of fuel, as: a. A chamber of any of various geometrical shapes in a gas-turbine engine, consisting of an outer cover or shroud enclosing one or more flame tubes, together with all fuel nozzles and associated components, within which fuel is burned, the resulting gases being exhausted through the turbine—also applied, in the singular, to a battery of such chambers in certain gas-

turbine engines. See MULTIPLE COMBUSTION CHAMBER. See also ANNULAR COMBUSTION CHAMBER, CAN, sense 1, CANNULAR COMBUSTION CHAMBER, REVERSE-FLOW COMBUSTION CHAMBER, STRAIGHT-FLOW COMBUSTION CHAMBER. b. The chamber of a rocket engine or motor within which the propellant or propellants are burned. See ROCKET, sense 2b. c. That section of a pulsejet or ramjet engine where the fuel is burned. d. A chamber or cup on a jet rotor blade where fuel is burned to give thrust to the blade. See PRESSURE JET. e. The space between the top of a piston and the cylinder head of an engine, esp. that space when the piston is at top dead center.

In senses a, b, c, and d, also called a "blast chamber," "burner," or "combustor"; in sense e, also called a "compression chamber." See PRECOMBUSTION CHAMBER.

combustion-chamber liner. Same as INNER LINER.

combustion efficiency. The efficiency with which fuel is burned, expressed as the ratio of the actual energy released by the combustion to the potential energy of the fuel.

combustion heater. A heater in which fuel is burned for heat. Used on aircraft, e. g., for cabin heating or ice-prevention systems.

combustion instability. Unsteadiness or abnormality in the combustion of fuel, as may occur, e. g., in a rocket engine.

combustion starter. Same as CARTRIDGE STARTER.

combustion wave. A zone of burning propagated through a combustible medium.

combustor, noun. A combustion chamber in a gas-turbine engine, rocket engine, or the like. See COMBUSTION CHAMBER and note.

command control. Same as COMMAND GUIDANCE.

command guidance. The guidance of a guided missile or other pilotless vehicle by means of electronic signals (or electric signals by wire for some short-range missiles) sent to receiving devices in the vehicle which cause it to follow a desired path.

—command guidance system.

commercial aviation. Aviation carried on by business enterprises for profit.

compass, noun. *Specif.,* a device for finding horizontal direction on the earth's surface.

See APERIODIC COMPASS, ASTROCOMPASS, CARD COMPASS, EARTH-INDUCTOR COMPASS, GYROCOMPASS, GYRO FLUX GATE COMPASS, GYROSYN COMPASS, MAGNESYN COMPASS, MAGNETIC COMPASS, RADIO COMPASS.

compass bearing. Bearing measured relative to compass north.

compass course. A course measured relative to compass north.

compass heading. A heading measured relative to compass north.

compass north. The direction toward which the north-seeking element of a magnetic compass points. This direction may differ from magnetic north because of local disturbances or errors in the compass.

compass rose. A circle marked in degrees, or sometimes in both directions and degrees, printed or inscribed upon a compass card, upon a chart for reference purposes, marked out upon the ground for use in compass swinging, or elsewhere displayed.

compass swinging. The action of turning an aircraft about to different headings to determine the deviation of its compass. This may be done in the air (airswinging) or on the ground (groundswinging).

composite aerial photograph. An aerial photograph assembled from photographs taken simultaneously with a multilens camera. Oblique photographs are transformed to the horizontal plane for the composite.

composite aircraft. 1. A term applied to two aircraft fastened or hitched together, usually a large airplane carrying a smaller airplane. 2. An aircraft having a composite power plant, e. g., a reciprocating engine and a jet engine.

composite power plant. A power plant consisting of two or more different types of engines, esp. such a power plant for aircraft consisting of a reciprocating engine and a jet engine. Cf. COMPOUND ENGINE.

compound engine. An engine in which the working substance is expanded through more than one major step in order to utilize power that would be otherwise lost; *specif.,* an aircraft engine consisting of a reciprocating engine to which one or more exhaust-driven turbines are added, the turbine power being utilized in some manner so as to increase the horsepower output of the engine, and commonly having the turbine exhaust directed to the

rear in order to produce extra thrust. The turbine power is most commonly delivered, by means of suitable gearing, to the engine crankshaft or to the propeller shaft, although the power may be used in some other manner, as to drive electrical accessories. (A turbosupercharged engine, however, is not customarily called a "compound engine.") In one form of compound engine, the turbine power is delivered both to the propeller shaft and to a compressor that delivers air to the engine cylinders. Cf. COMPOSITE POWER PLANT.

compound helicopter. A GYRODYNE. *Rare.*

compressibility, noun. The property of a substance, as air, by virtue of which its density increases with increase in pressure.

In aerodynamics, this property of the air is manifested esp. at high speeds (speeds approaching that of sound and higher speeds). Compressibility of the air about an aircraft may give rise to buffeting, aileron buzz, shifts in trim, and other phenomena not ordinarily encountered at low speeds, known generally as compressibility effects.

compressibility burble. Burble, or a region of disturbed flow, produced by, and aft of, a shock wave. See BURBLE.

compressibility stall. Same as SHOCK-STALL. *Rare.*

compressible flow. In aerodynamics, flow at speeds sufficiently high that density changes in the fluid can no longer be neglected.

compression chamber. Specif., a combustion chamber in a piston engine. See COMBUSTION CHAMBER, sense e.

compression-ignition engine. An internal-combustion reciprocating engine in which the fuel is ignited in the cylinder by the heat of the air compressed by the piston. See DIESEL ENGINE.

compression ratio. The ratio of a volume before compression to the volume after compression. For example, in an internal-combustion reciprocating engine, the compression ratio is the ratio of the volume in a cylinder at the beginning of the compression stroke to the volume at the end of the stroke. Cf. EXPANSION RATIO, PRESSURE RATIO.

compression rib. A rib, more strongly built than others, designed esp. to resist compression forces.

compression shock wave, or compression shock. Same as SHOCK WAVE.

compression stroke. In a four-stroke-cycle engine, the stroke or movement of a piston to compress the air or mixture in the cylinder.

compression wave. 1. A shock wave, when the emphasis is upon the compression of the fluid passing through it—disting. from an EXPANSION WAVE. 2. A wave in a fluid flow across which the compression is slight or infinitesimal.

compressor, noun. A machine for compressing air or other fluid.

Compressors are distinguished (1) by the manner in which fluid is handled or compressed, as the *axial-flow, centrifugal, double-entry, free-vortex, mixed-flow, positive-displacement, radial-flow, single-entry,* and *supersonic compressor*, or (2) by the number of stages, as the *multistage* or *single-stage compressor*. (See individual entries on the different types.)

compressor blade. Either a rotor blade or a stator blade in an axial-flow compressor; sometimes used restrictively (and ambiguously) for a compressor rotor blade. Cf. IMPELLER VANE.

compressor efficiency. The efficiency with which a compressor performs its work; specif., the adiabatic efficiency of a compressor. See ADIABATIC EFFICIENCY, POLYTROPIC COMPRESSOR EFFICIENCY.

compressor pressure ratio. The ratio between inlet and outlet pressures in a compressor.

compressor stall. A condition occurring in a rotary air compressor when some of the blades or vanes meet the airflow at such an angle that there is a reversal of flow, often leading to flame-out in a gas-turbine engine.

In a compressor stall, the angle of attack of the blades is analogous to the angle of attack of a wing operating at an angle greater than the angle of maximum lift. See BLADE STALL, sense b, ROTATING STALL.

computed altitude. *Nav.* The angular altitude of a celestial body, esp. its angular altitude above the celestial horizon, computed for an assumed position at a given time.

computer, noun. An instrument or device that computes, or that is used in computing, as in solving mathematical problems in navigation or guidance; one who computes, or who operates a computer. See COURSE-LINE COMPUTER, NAVIGATION COMPUTER.

concentration ring. A hoop where divergent ropes, lines, or cables are brought together, such as the ring or hoop on

certain free balloons where the lines from the net to the basket are collected. See LOAD RING.

condensation shock wave, or condensation shock. A sheet of discontinuity associated with a sudden condensation and fog formation in a field of flow. It occurs, e. g., on a wing, where a rapid drop in pressure causes the temperature to drop considerably below the dew point.

condensation trail. A visible trail of condensed water vapor or ice particles left behind an aircraft, an airfoil, etc. in motion through the air. Also called a "contrail" or "vapor trail."

There are three kinds of condensation trails: the *aerodynamic* type, caused by reduced pressure of the air in certain areas as it flows past the aircraft; the *convection* type, caused by the rising of air warmed by an engine; and the *engine-exhaust*, or *exhaust moisture*, type, formed by the ejection of water vapor from an engine into a cold atmosphere.

conductance, noun. The capability of something to convey, such as the capability of a ducting system to convey a flow; conductivity.

conductivity, noun. The property of something to conduct, such as the property of a metal to conduct electricity or heat; conductance.

cone, noun. Something shaped more or less like a geometrical cone, e. g., a cone of silence, an entrance cone, an exhaust cone, an exit cone, a Mach cone, a mooring cone, a nose cone, or a tail cone. (See individual entries.)

cone of silence. 1. An inverted cone-shaped space immediately above the transmitting station of a four-course radio range in which signals are received faintly or not at all. See LOOP-TYPE RADIO RANGE (illus.). 2. By extension, any cone-shaped area extending away from a radar transmitter, in which there is little or no signal intensity.

conical camber. The camber of an airfoil having a surface that forms a portion of the surface of a cone, not necessarily a right circular cone, with the apex of the cone located in the plane of symmetry of the airplane. Usually applied only to the leading or forward portion of a wing producing a wing with leading edge curvature that increases progressively with spanwise distance from the fuselage.

conical scanning. Radar scanning in which the radio-frequency beam generates a cone-shaped pattern, the apex of the cone being at the radar antenna.

coning, noun. The action of a rotor blade or of rotor blades slanting or lifting upward to form a cone-shaped pattern of rotation with the apex of the cone at the point of rotation. In coning, a blade assumes a position resultant of the lift force and centrifugal force acting upon it.

coning angle. The average angle between the span axis of a blade of a rotary-wing system and a plane perpendicular to the axis of rotation, or, sometimes, perpendicular to some other chosen reference axis.

Consol, noun. A long-range, low-frequency, radio-navigation system using a rotating pattern of dots and dashes and equisignal zones. Bearing to the transmitter is determined by counting the dots and dashes on each side of an equisignal zone and by reference to a special chart.

Consol is an adaptation of the German Sonne system of WW II.

console, noun. Something suggesting the console of an organ, such as a pedestal or stand fitted out with instruments, controlling levers and switches, etc., installed, e. g., between the pilot's and copilot's seats on an airplane. See CONTROL PEDESTAL.

constant-speed propeller. A propeller designed to maintain engine speed at a constant rpm, automatically increasing or decreasing pitch as engine speed tends to increase or decrease.

construction weight. The weight of a wingless rocket exclusive of propellant, load, and crew, if any. Also called "structural weight" (which see).

contact, noun. 1. The state of an aircraft's ignition system when the circuit is closed—used by a person swinging the aircraft's propeller as a request that the ignition switch be turned on, or by the person in the cockpit as affirmation that the switch is on. 2. In elliptical usage, contact, or visual, flight or visual flight conditions, as, to go into *contact*. See CONTACT, *adj.*

contact, adj. Visual, as in *contact* conditions; characterized by conditions permitting vision in flying, as, an airfield that is *contact*.—*adv.* By visual

reference to the ground, as, to fly *contact*. See CONTACT, *noun*, sense 2.

contact flight rules. Same as VISUAL FLIGHT RULES.

contact flying. Flying in which a pilot ascertains his aircraft's attitude and finds his way from place to place by visual reference to the horizon and to landmarks. Cf. PILOTAGE.

contact light. Same as RUNWAY LIGHT.

continuous pressure breathing. Pressure breathing in which the pressure inside the breathing mask is maintained at a substantially constant pressure. See PRESSURE BREATHING.

continuous-strip camera. A type of aerial camera that takes an unbroken still photograph of the ground beneath a moving aircraft, employing a roll of film moving past a slit, the speed at which the film moves being adjusted to the ground speed of the aircraft.

contour line. A line on a map or chart joining topographic points of equal elevation.

contraction ratio. The ratio of the uncontracted cross-sectional area of a duct or passage to the contracted cross-sectional area, such as the ratio of the uncontracted cross-sectional area of a wind tunnel to the cross-sectional area of the throat.

contrail, noun. Same as CONDENSATION TRAIL.

contrapropeller, or contrapropellers, noun. Same as CONTRAROTATING PROPELLER (in sense 1 or sense 2).

contrarotating propeller. 1. A propeller that rotates in a direction opposite to that of another propeller with which it is mounted coaxially. 2. Also contrarotating propellers. A set of coaxial propellers rotating in opposite directions.

contrarotating rotor. 1. A rotor rotating in a direction opposite to that of another with which it is mounted coaxially. 2. Usually contrarotating rotors. A set of coaxial rotors rotating counter to one another.

contravane, noun. A vane that reverses or neutralizes a rotation of a flow. Also called a "countervane."

control, noun. 1. Direction, regulation, or restraint. 2. A lever, switch, cable, knob, push button, or other device or apparatus by means of which direction, regulation, or restraint is exercised over something. 3. In plural. a.

A system or assembly of levers, gears, wheels, cables, boosters, valves, etc. used to control the attitude, direction, movement, power, and speed of an aircraft, rocket, etc.; specif., the system of levers, pedals, etc. in an aircraft cockpit used to deflect the control surfaces. b. Control surfaces. 4. Sometimes capitalized. An activity or organization that directs or regulates air traffic. See AIR TRAFFIC CONTROL.

control area. An airspace of given dimensions within which air traffic control is exercised.

control axis. In a rotary-wing system, a rotor axis along which the rotor thrust is directed, and hence through which control is exercised; an axis of no feathering.

control booster. A relay motor, mechanism, or device, such as a hydraulic motor or a servo tab, that applies force to move a control surface when the pilot moves the cockpit control.

control cabin. The cabin in an aircraft from which its flight direction, power, etc. are controlled; a pilot's cabin. See CONTROL CAR.

control cable. A cable for transmitting controlling movement, esp. a cable for moving the control surfaces of an airplane or other aircraft, either directly or through intermediate mechanisms, or a cable connecting two or more control surfaces. Cf. CONTROL LINE, sense 1.

control car. The car on an airship from which the flight direction, power, etc., are controlled.

control channel. An electrical or radio-frequency channel through or by means of which control is exercised.

control column. A lever or post having a wheel, half-wheel, or other rotatable device mounted at its upper end, used in controlling the flight direction of an aircraft. On an airplane, the control column is a lever, moved back and forth to operate the elevators, the wheel or other device being rotated to move the ailerons; on certain airships, the control column mounts a wheel (or the like) used for rudder operation, the elevators being operated by a separate control. Cf. CONTROL STICK.

control feel. The feel or impression of the stability and control of an aircraft that a pilot receives through the cockpit controls, either from the aerody-

dynamic forces acting on the control surfaces or from forces simulating these aerodynamic forces. See ARTIFICIAL FEEL and FEEL.

control force. a. An aerodynamic force acting on a control surface. **b.** A deflecting force exerted on a control surface by the pilot or by power devices in the aircraft control system.

control-force recorder. An instrument that measures and records the force exerted to move a control or control surface.

control-force reversal. A reversal of the aerodynamic forces acting on a control surface in such a way that the aerodynamic forces act to increase the control deflection.

control-gearing ratio. The ratio of the angular deflection of a control surface to the angular movement of the cockpit control required to cause the given deflection.

control horn. A short lever or post rigidly fixed to a control surface, to which a control cable, wire, line, or rod is attached. See HORN, sense 1.

Called a "horn," a control horn is sometimes distinguished by a term signifying the surface to which it is fixed, as in aileron horn, elevator horn, etc.

controllability, noun. The capability of an aircraft, rocket, or other vehicle to respond to control, esp. in direction or attitude.

controllable, adj. Of a tab, propeller, stabilizer, etc.: Capable of being set or controlled from the cockpit during flight or operation—sometimes (though not necessarily) disting. from "adjustable": see note.

The terms "adjustable," "controllable," "fixed," and "movable," as used in different compounds may be seen to have self-conflicting meanings: For example, an "adjustable" propeller is neither "controllable" nor "fixed," but an "adjustable" stabilizer may be "controllable" and a "fixed" trim tab can be adjusted; likewise, a "fixed" stabilizer is not "adjustable," but a "fixed" surface may be "adjustable" but not "movable." The terms are used relatively and logically for the most part, however, and confusion of meaning seldom exists in context. See ADJUSTABLE-PITCH PROPELLER, ADJUSTABLE STABILIZER, CONTROLLABLE-PITCH PROPELLER, FIXED STABILIZER, note, FIXED SURFACE, MOVABLE SURFACE, TRIM TAB, note.

controllable-pitch propeller. A propeller whose blade angle may be changed from the cockpit while the propeller is rotating; specif., such a propeller whose blade angle may be changed to either of only two angles, high or low.

Also called a **controllable propeller**. Cf. ADJUSTABLE-PITCH PROPELLER.

control lag. A time lapse occurring between the movement of a control and the response or effect which the movement brings about, as between the movement of a cockpit control in an aircraft and the responsive movement of the aircraft.

controlled-failure point. A load at which a structure is designed to fail.

controlled mosaic. A mosaic composed of two or more aerial photographs of the same scale oriented with respect to one another and fitted together so as to maintain an accurate scale between points of known location.

controlled spin. Same as NORMAL SPIN (in sense 2).

controller, noun. One who controls, or is responsible for controlling, air traffic or the movement or direction of aircraft, guided missiles, or the like; an apparatus or device that controls something, or that is used in controlling.

control line. 1. On an airship, a line or cable leading from the control car and operating, either directly or through intermediate mechanisms, a gas valve, a control surface, or other controlling device. Sometimes also called a "control cable" or "control wire," where appropriate. See CONTROL CABLE. 2. A line attached to the controls of a flying model aircraft and manipulated by an operator on the ground.

control lock. A securing device to prevent movement of a control or control surface.

control panel. A panel or board fitted out with switches, instruments, relays, circuit breakers, etc. for controlling and supervising the operation of equipment or systems.

control pedestal. On an aircraft, a stand between the pilot's and copilot's seats having controls, esp. engine controls, mounted on it. See CONSOLE.

control point. 1. In air navigation, a specified point over which an aircraft is to be at a predetermined time. 2. *Aerial Photography.* A point of known geographic location on an aerial photograph, used as a reference point in assembling a controlled mosaic.

control-position recorder. An instrument that measures and records the angular deflections of a control surface.

control quadrant. A kind of control stand or box in an aircraft featuring at its top a slotted, rounded plate from which various controls project, such as the throttle lever, mixture-control lever, propeller-pitch lever, etc.

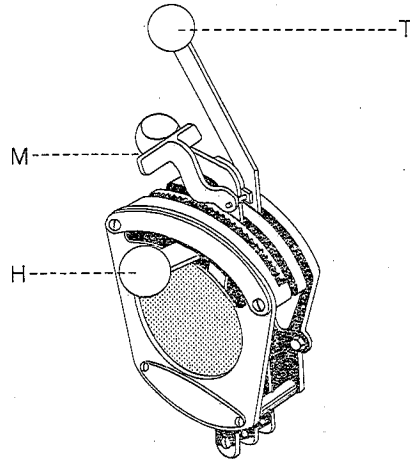

Control quadrant for a lightplane. T throttle lever; M mixture-control lever; H carburetor-heat lever.

control rod. A rod used in controlling something; specif., a rod used to transmit motion to a control surface.

control rotor. A small servo rotor mounted coaxially with the main rotor on certain helicopters, the displacement of which by the pilot causes the main rotor to be displaced to direct the thrust. By a damping action the control rotor usually also contributes to the stability of the helicopter.

control stick. A lever for controlling the movements of an aircraft in flight. On a fixed-wing airplane, the control stick operates the elevators by a back-and-forth movement and the ailerons by a side-to-side movement; on a helicopter, the control stick operates the rotor so as to obtain rotor thrust in a chosen direction.

control surface. A movable airfoil or surface, such as an aileron, elevator, ruddervator, flap, trim tab, etc. used to control the attitude or motion of an aircraft, rocket missile, or other body and to guide it through the air; specif., one of the major surfaces used principally for guidance, as an elevator, rudder, elevon, etc.

control-surface area. The area within the outline of a control surface exclusive of any area on that side of the hinge axis nearer the fixed surface to which the control surface is attached. The area of any tabs set into the control surface is normally included, but the area of any tabs lying outside the control surface proper is not included.

control tower. An elevated structure or place at an airdrome from which air traffic entering and leaving the airdrome is controlled; the personnel operating this tower, as, to ask the control tower for landing permission.

The control tower also directs ground traffic in the take-off and landing area.

control vane. A movable vane used for control, esp. a movable air vane or jet vane on a rocket, used to control flight direction. See AIR VANE, JET VANE.

control wheel. A wheel, semiwheel, or the like used in controlling something, esp. the wheel or sector of a wheel atop a control column in an airplane or airship.

control wire. A wire serving the same purpose as a control line or cable. See CONTROL CABLE, CONTROL LINE, sense 1.

control zone. An airspace of specified dimensions extending upward from the surface and including one or more airdromes, within which air-traffic-control rules in addition to those governing control areas are in effect.

convection condensation trail. A type of condensation trail made visible by cooling due to convection. See CONDENSATION TRAIL and note.

convection current. *Meteorol.* An air current caused by convection, esp. thermal convection; a THERMAL.

convertiplane, noun. Variant of "convertiplane."

convertible, adj. Of an aircraft: Capable of being changed from one type or kind of aircraft to another or from an aircraft into another kind of vehicle, etc.; e. g., capable with minimum modification of serving in two or more capacities, as that of passenger or cargo transport; readily changeable from an aircraft into a road vehicle; capable of being quickly converted from a landplane into a seaplane, etc., but not amphibious; capable of flying as a helicopter or fixed-wing airplane. See CONVERTIPLANE.

convertiplane, noun. A hybrid form of heavier-than-air aircraft that is capable, by virtue of one or more horizontal rotors or units acting as such rotors, of taking off, hovering, and landing as, or in a fashion similar to, a helicopter and, once aloft and moving forward, capable, by means of a mechanical conversion of one sort or another, of flying purely as a fixed-wing aircraft, esp. in its higher speed ranges, intermediate-stage and low-speed flight customarily being performed as a helicopter or as both a helicopter and a fixed-wing aircraft.

Convertiplane designs include arrangements in which airscrews are mechanically adjusted to rotate in either a horizontal or a vertical plane, to serve as rotors or as propellers; in which the rotor blades are locked to serve as fixed wings; and in which the rotor is stowed for fixed-wing flight.

An exact definition of "convertiplane" has been a matter of some concern and attendant confusion in the aeronautical community. Generally speaking, however, gyrodynes and fixed-wing airplanes that take off and land vertically ("tail sitters") are not considered convertiplanes.

coolant, noun. A liquid or gas used to cool something, as a reciprocating engine or rocket combustion chamber.

This word is used in many self-explanatory compounds, which include: coolant chamber, coolant gallery, coolant hose, coolant jacket, coolant passage, coolant pump, coolant radiator, coolant shutter (for the flow of cooling air), and coolant tank. See COOLING, noun and note.

cooler, noun. A device used to cool, as in a wind tunnel for cooling the air or gas in the tunnel. See OIL COOLER.

An air exchanger in a wind tunnel is not considered a cooler. See RADIATOR, sense 2 and note.

cooling, noun. The action of making cooler or cold, of dissipating heat from something.

Used in self-explanatory compounds, such as cooling duct, cooling jacket (to contain a cooling fluid), cooling shutter, cooling tank, etc. In attributive use the noun "cooling" is sometimes interchangeable with "coolant" (which see, and note). Also see COOLING, adj.

cooling, adj. That cools, as in cooling air, cooling fan, cooling fluid. See COOLING, noun and note.

cooling drag. The drag on an aircraft resulting from the passing of air over or through finned engine cylinders, radiators, ducts, and other cooling devices or apparatus.

cooling fin. Any one of a number of fins or flat surfaces used for cooling, such as one machined or cast into, or fastened to, an air-cooled engine

cylinder or other air-cooled machine, offering its surface area to the air to provide more effective cooling.

copilot, noun. 1. On certain aircraft, a fellow pilot who assists the regular pilot (the regular pilot being usually called the "pilot" or "first pilot") in his duties and sometimes flies the aircraft; a person trained or rated to perform this duty. 2. On certain airships, the person who operates the rudder controls. Cf. AIRSHIP PILOT.

copter, noun. A clipped form of the word "helicopter." Popular.

Coriolis effect or Coriolis acceleration.

[After Gaspard Gustave de *Coriolis* (1792-1843), French engineer and mathematician.] An acceleration affecting any particle moving over a rotating surface. The direction of the acceleration is normal to both the axis of rotation and to the direction of the apparent velocity, and the magnitude is twice the product of the angular velocity of the surface and the apparent velocity of the particle. This effect is observable, e. g., (1) in a deflection to the right of the line of movement of an aircraft, air mass, etc. moving in the earth's northern hemisphere and to the left for bodies moving in the southern hemisphere, and (2) in the oscillation of a rotary-wing aircraft's rotor blade about its drag hinge, caused by the alternating increase and decrease in distance of the center of the blade mass from the center of rotation as the blade flaps.

corkscrew, verb intr. Of an aircraft or persons within: To spiral or to turn repeatedly right and left, describing a flight path suggestive of a corkscrew.

corrected, adj. Of pressure altitude or of airspeed: True. Rare.

counterflow burner. Same as REVERSE-FLOW COMBUSTION CHAMBER.

counterpressure, noun. A pressure applied to the exterior of the human body to counteract a pressure introduced inside during pressure breathing.

counter-rotating propeller. Same as CONTRAROTATING PROPELLER (in sense 1 or sense 2).

counter-rotating rotor. Same as CONTRAROTATING ROTOR (in sense 1 or sense 2).

The singular form is infrequent in sense 2.

countervane, noun. Same as CONTRAVANE.

course, noun. 1. a. A predetermined or intended route or direction to be followed, measured with respect to a geographic reference direction; a line on a chart representing a course;—course made good, a resultant direction of flight represented by a straight line on a chart connecting the point of departure with the latest fix. b. A track or route to be followed, as in airplane racing. 2. A line of flight taken by an aircraft, rocket, etc. 3. A radio beam in a radio range.

In sense 1a, see COMPASS COURSE, GREAT-CIRCLE COURSE, GRID COURSE, MAGNETIC COURSE, RHUMB-LINE COURSE, TRUE COURSE; in sense 1b, see CLOSED COURSE; in either sense 1a or sense 2, see COLLISION COURSE.

course light. A light directing a beam along an airway or toward an airport.

Course lights mounted on an airway beacon may flash a code to identify the beacon location. Course lights also have different colors to indicate whether a nearby airfield is lighted or unlighted, or whether no airfield is nearby.

course line. 1. A line of position plotted on a chart, parallel or substantially parallel to the intended course of an aircraft, showing whether the aircraft is to the right or the left of its course. 2. Any line representing a course.

course-line computer. An airborne computing machine used in connection with omnirange and distance-measuring equipment to provide continuous indication of an aircraft's position in terms of deviation from a proposed course and of distance to destination. The equipment permits flying a course to one side of an omnirange station rather than directly to or from the station.

course marker. A ground marker used to mark a course, such as a closed course, in a race or speed run.

course selector. A manually operated navigation instrument that is operated in conjunction with a VHF omnidirectional radio range to show direction to or from the range station.

course signal. A radio signal signifying a course in a radio range. See EQUISIGNAL ZONE.

cove, noun. A kind of nook in a sea-plane float or hull, formed where two surfaces meet so as to create an angle of intersection whose vertex points inward; the line of intersection of this juncture.

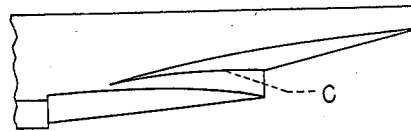

Cove.

cowl, noun. Same as COWLING (in sense 1).

cowl, verb tr. To cover with a cowling or with cowlings.

cowl flap. One of several shutters in an aircraft engine cowling, used to regulate the flow of cooling air around the engine.

cowling, noun. 1. A removable cover or housing placed over or around an aircraft component or section, esp. an engine. Also called a "cowl." See ENGINE COWLING. 2. The action of the verb *cowl*. 3. The material or parts used in cowling.

In sense 3, "cowling" is construed as a singular noun, as in "The cowling was removed"; in this sense the word is analogous to "tubing," "wiring," etc.

cowl ring. An engine cowling likened to a ring; a RING COWLING.

crab, noun. 1. The motion or action of crabbing. 2. *Aerial Photography.* The condition of an aerial photograph that is askew to the line of flight of the photographing aircraft, resulting from the crabbing action of the aircraft without a corresponding change in the orientation of the camera.

crab, verb intr. Of an aircraft: To fly with the nose turned to the right or left of the line of flight, as when compensating for wind effect.—*tr.* To put (an aircraft) into a crabbed attitude.

crab angle. Same as ANGLE OF CRAB.

crack, verb intr. To crack up. To crash—said of aircraft or persons.—*tr.* To crash (an aircraft). *Popular.*

crack-up, noun. An act or instance of cracking up. *Popular.*

craft, noun. *Specif.:* 1. An aircraft, or aircraft collectively. 2. Any vehicle or machine designed to fly through air or space. Also *collective.* See MACHINE and note, VEHICLE and note.

"The pilot of a manned rocket craft will be transposed . . . into the region of free space." Heinz Haber, in *Physics and Medicine of the Upper Atmosphere.*

cranked wing. A wing whose spanwise axis abruptly departs from a straight line, as seen either in planform or in a vertical plane.

A gull wing is one form of cranked wing.

crash, noun. An act or instance of crashing; a crashed aircraft or other vehicle, or the scene of a crash, as, to leave a crash.

crash, verb. 1. *intr.* While flying, to strike or smash against the surface of the earth (either land or water) or against a structure or object on the surface in such a manner that the aircraft or other flying vehicle is severely damaged or is destroyed. Said of an aircraft, etc., or of persons within. 2. *tr.* To fly or guide (an aircraft, rocket) etc., against something in such a manner that a crash results.

crash crew. A crew that performs rescue work and fights fires in crashes.

crash helmet. A sturdy helmet designed to protect the head, esp. in a crash.

crash-land, verb. 1. *intr.* To make a crash landing; to belly-land. 2. *tr.* To land (an aircraft, rocket, etc.) in such a manner that a crash results.

crash landing. A landing in which a crash occurs.

crash position. The station occupied by a person or the prescribed bodily position assumed for a crash.

creep, noun. 1. A slow deformation of a material, body, or structure under a constant or prolonged load, or, with reference to bodies such as turbine blades, under prolonged stress and temperature. 2. The continuing deflection of an instrument needle or of an indicator after initial deflection under an exciting force. 3. An unwanted play or movement in a mechanism.

crescent wing. A wing having its angle of sweep progressively decreased from root to tip such that the leading edge is curved like a crescent.

—crescent-winged, *adj.*

crew, noun. A body or team of people serving or manning a vehicle or piece of equipment, or otherwise working together; *specif.*, an AIRCREW. See also GROUND CREW.

critical altitude. Any altitude above which the performance of equipment falls off, above which some particular danger exists, above which some condition is encountered requiring special attention, etc., and therefore regarded as critical, as: a. The maximum altitude at which a supercharger can maintain a pressure in the intake manifold

of an engine equal to that existing without the supercharger at rated power and speed at sea level, or the maximum altitude at which any kind of propulsion system can meet performance specifications. b. An altitude above which harmful effects from cosmic radiation may occur.

critical angle of attack. Any angle of attack considered critical for one reason or another, esp. the minimum angle of attack of a given airfoil or airfoil section at which extensive flow separation occurs, with a consequent loss of lift and increase of drag. Cf. STALLING ANGLE.

critical Mach number. The free-stream Mach number at which a local Mach number of 1.0 is attained at any point on the body under consideration.

For example, an airplane traveling at a Mach number of 0.8 with respect to the undisturbed flow might attain a Mach number of 1 in the flow about the wing; the critical Mach number would thus be 0.8.

critical pressure. A pressure regarded as critical, as: a. In rocketry, the external pressure below which there is no increase in the velocity of efflux of the exhaust gas flow from a nozzle. b. The pressure required to liquefy a gas at the highest temperature at which the gas will liquefy.

critical Reynolds number. The Reynolds number at which some significant change occurs, e. g., the Reynolds number at which a transition from laminar to turbulent flow begins, or at which the drag of a cylinder or sphere drops sharply.

critical speed. Any speed regarded as critical for one reason or another, as: a. The speed of an airplane at which compressibility effects are encountered. b. The speed corresponding to a critical Mach number. c. The lowest speed at which an airplane can become, or remain, airborne, i. e., flying speed. d. The rotational speed, as of an engine, at which resonance sets in.

cross, verb tr. To cross the controls. To move the controls of an airplane in a direction opposite to the usual for a given maneuver or performance, e. g., to deflect the right aileron downward while holding right rudder.

cross bearing. A bearing crossing another bearing, as drawn on a chart, providing a fix at the point of intersection.

cross country. A CROSS-COUNTRY FLIGHT.—*adv. phr.* as, to fly *cross country*.

cross-country flight. A flight across land away from the immediate vicinity of an airfield, usually restricted to a flight in which landing is made at a place or places other than the original point of departure.

Henri Farman (1874-1934) is credited with making the first *cross-country* flight, from Bouy to Rheims, France, a distance of 17 miles, on October 30, 1908; the ICAO considers 17 nautical miles the minimum distance for a *cross-country* flight.

cross coupling. 1. The coupling together of two control surfaces, e. g., a rudder and an aileron, so that each deflects with the deflection of the other. 2. The coupling of motions about two different axes, e. g., the coupling that occurs when a motion about the longitudinal axis of an aircraft induces a motion about the lateral axis.

cross-deck pendant. An arresting cable or wire across the deck of an aircraft carrier. See ARRESTING GEAR.

cross feed. The feeding or transfer of fuel or oil from engine to engine or from tank to tank on a multiengine aircraft.

cross flow. A flow going across another, flow, as a spanwise flow over a wing.

cross-ignition tube. A tube that carries igniting flame from one combustion chamber to another in certain gas-turbine engines.

cross-pointer indicator. An aircraft instrument having two crossing needles that indicate the position of the aircraft with respect to the localizer beam and to the glide slope in an instrument landing system.

cross wind, or crosswind, noun. A wind blowing across the line of flight of an aircraft, rocket, etc. such that its chief effect is to drive the aircraft or other flying body sideways; a wind blowing across, as across a runway.

cross-wind force. That component of the total aerodynamic force acting on a body that is perpendicular to the forces of lift and drag.

cross-wind landing gear. A castering landing gear permitting an aircraft to land in a crabbed attitude.

crow's-foot, noun. 1. A system or pattern of diverging short ropes for dis-

tributing the pull of a single rope, as in balloon and airship rigging. 2. A group of strands separated and spread out at the end of a cord or rope and cemented or otherwise fastened against a fabric surface.

cruciform, adj. Cross-shaped, as in *cruciform* empennage, *cruciform* tail, an empennage or tail in which the surfaces cross one another so as to form a symmetrical +-shaped or X-shaped cross.

cruise, noun. The act of cruising; a cruising flight.

cruise, verb intr. To fly at approximately constant speed and altitude, esp. at power settings recommended for maximum range, efficiency, etc.

cruise control. The act or practice of operating an aircraft so as to achieve the most efficient performance on a given flight under the available conditions. Cruise control may be instituted to obtain maximum economy, endurance, speed, or range, or maximum efficiency at a predetermined airspeed or power setting.

cruising airspeed. The airspeed at which an aircraft cruises. The cruising airspeed for any given aircraft changes with the purpose involved, and with the altitude, winds, load, and other variables.

cruising altitude. A given indicated pressure altitude specified for cruising, or maintained in cruising. See INDICATED PRESSURE ALTITUDE.

cruising radius. The maximum distance that an aircraft, starting with its fuel tanks full, can cruise under the given or specified conditions from its take-off point before returning, with a specified fuel reserve remaining at the end of its flight.

cruising speed. The speed at which an aircraft cruises; a CRUISING AIRSPEED.

C-scope, noun. A radarscope that presents azimuth by deflection of the target signal along a horizontal scale and elevation by deflection along a vertical scale.

Cuban eight. A stunt or flight maneuver in which an airplane describes an eight-shaped flight path in the vertical plane by completing about three quarters of an inside loop, half-rolling, then repeating the procedure.

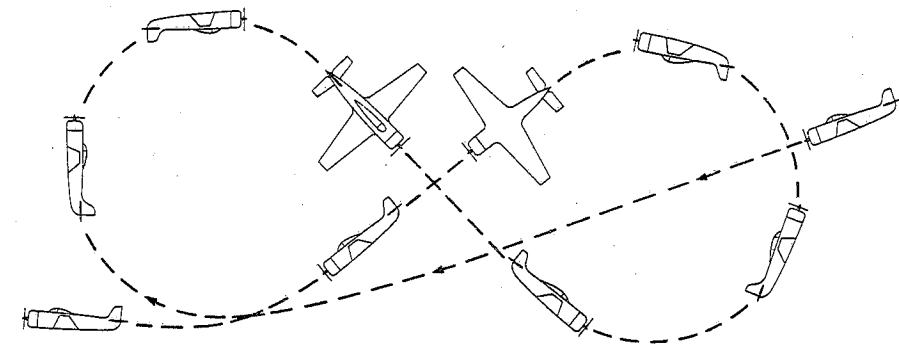

Cuban eight.

cuff, noun. A PROPELLER CUFF.

current, noun. Specif., an AIR CURRENT.

curtain, noun. 1. In an airship, a fabric panel that helps support a car; a CATENARY CURTAIN. 2. A FACE CURTAIN. 3. On certain early airplanes, a vertical panel, parallel to the plane of symmetry, between the wings or other horizontal surfaces.

cut, verb tr. To cut a pylon. In airplane racing, to make a turn inside the pylon marking the turn.

cut-off, or cutoff, noun. 1. An act or instance of shutting something off; specif., *Rocketry*, an act or instance of shutting off the propellant flow in a rocket, or of making the propellant cease to burn. Cf. BURNOUT, sense 1. 2. Something that shuts off, or is used to shut off. See IDLE CUT-OFF.

cycle, noun. A recurring course or set of values, actions, operations, or events at the end of which the original conditions are restored, as: a. A recurring series of operations which the working substance undergoes in an internal-combustion engine. See CARNOT CYCLE, DIESEL CYCLE, JOULE CYCLE, OTTO CYCLE; see also CLOSED-CYCLE ENGINE, OPEN-CYCLE ENGINE. b. A recurring set of actions that a reciprocating internal-

combustion engine performs in its operation. See FOUR-STROKE-CYCLE ENGINE, TWO-STROKE-CYCLE ENGINE.

See also STRESS CYCLE.

cycle efficiency. The efficiency of a given cycle in producing work, expressed as the useful work output divided by the work input. For a gas-turbine engine, the cycle efficiency is the useful work energy less the work required for compression divided by the heat energy in the fuel used; for a reciprocating engine, it is the energy of the indicated horsepower divided by the heat energy of the fuel.

cycle ratio. The ratio of the number of cycles applied to a member at a given stress to the number that would cause failure at that stress.

cyclic pitch control. A control mechanism for periodically varying the blade angle of each blade in a rotor in its cycle of rotation, producing a tilt in the tip-path plane to obtain motion in a desired direction; the control exercised through this mechanism.

cyclic pitch stick. A control stick for cyclic pitch control. See CONTROL STICK and cf. PITCH LEVER.

cylinder baffle. An air deflector for an engine cylinder. See BAFFLE, sense a.

D

danger area. An area in which invisible hazards to flight exist, to be flown over only by permission of the proper authority.

dashboard, noun. An instrument board directly beneath the windshield in certain airplanes, analogous to the dashboard in an automobile.

D-duct, noun. A duct of D-shaped cross section, used, e. g., to convey hot air in the leading edge of a wing for anti-icing or de-icing.

dead reckoning, *Nav.* The estimating or determining of position by advancing an earlier known position by the application of direction and speed data.

dead rise, 1. The vertical distance between the chine and the keel of a boat, hull, or float. **2. Also** dead-rise angle. The ANGLE OF DEAD RISE.

dead-stick, *adj. and adv.,* without power, as in *dead-stick* landing, or as, to land *dead-stick*.

decalage, noun. The angular difference between the mean aerodynamic chords of two specified aircraft surfaces set at different angles of incidence, commonly this angular difference between two wings of a biplane or multiplane, but also applied to two approximately horizontal surfaces in tandem, such as the wing and stabilizer of a monoplane; also, a setting of surfaces that incorporates this angular difference.

Decalage is considered positive when an upper surface is at a greater angle of incidence than a lower surface, or when the forward surface of a tandem arrangement is at the greater angle. The decalage of tandem surfaces is sometimes called "longitudinal decalage."

deceleration, noun, 1. The act or process of moving, or of causing to move, with decreasing speed; the state of so moving. **2.** A force causing deceleration; also, inertial force.

Sometimes called "negative acceleration" (which see).

deceleration parachute. A parachute attached to an aircraft and deployed to slow the aircraft, esp. during landing. Also called a "brake parachute" or "parabrake." See DROGUE PARACHUTE.

deceleron, noun. [*Decelerator*+*aileron*.] A combination air brake and aileron.

deck, noun, 1. A floor or level in a vessel or in certain aircraft; the platform on an aircraft carrier for the take-off and landing of aircraft. See FLIGHT DECK. **2.** The upper surface of a float. **3.** A wing, esp. of a biplane or multiplane. **4. a.** A layer of stratus cloud. **b.** A CLOUD DECK. **5.** The surface of the earth; a very low flight

altitude, just above the earth's surface. *Slang* or *popular*.

declination, noun. The angular distance of a body from the celestial equator, measured along the hour circle passing through the body and named *north* or *south* according to the direction of the body from the celestial equator. See CO-DECLINATION.

decompression, noun. The act or process of lowering the air pressure within a cabin, chamber, etc., or of subjecting to, or undergoing, a decrease in air or atmospheric pressure. See EXPLOSIVE DECOMPRESSION.

decompression chamber. A chamber in which the air pressure is lowered to simulate conditions at altitude.

decompression sickness. Sickness brought on by decompression; AEROEMBOLISM, sense 2.

Dee ring. Same as D-RING.

deflagration, noun. A sudden or rapid burning, as opposed to a detonation or explosion.

deflect, verb *tr.* Specif., to rotate a control surface about its hinge line.

deflector, noun. A plate, baffle, or the like that diverts something in its movement or flow, as: **a.** A plate that projects into the airstream on the underside of an airfoil to divert the airflow, as into a slot—sometimes distinguishing from a SPOILER. **b.** A conelike device placed or fastened beneath a rocket launched from the vertical position, to deflect the exhaust gases to the sides. **c.** Any of several different devices used on jet engines to reverse or divert the exhaust gases. **d.** A baffle or the like to deflect and mingle fluids prior to combustion, as in certain jet engines.

de-icer, noun, 1. A device or substance for removing ice formed on an aircraft. See DE-ICER BOOT. **2.** Loosely, an ANTI-ICER.

de-icer boot. A rubber strip on the leading edge of an airfoil, inflatable with compressed air to break up ice which has formed.

de-icing, noun, 1. The breaking off or melting of ice formed on aircraft surfaces, in an induction system, etc. **2.** Loosely, ANTI-ICING.

de Laval nozzle. [After Dr. Carl Gustaf Patrik *de Laval* (1845-1913), Swedish engineer.] A converging-diverging nozzle, used, e. g., in certain rockets.

delayed drop, or delayed jump. Same as DELAYED-RELEASE JUMP.

delayed-release jump. A parachute jump in which the parachutist delays longer than usual before pulling the rip cord.

delayer, noun. A substance mixed in with solid rocket propellants, esp. to decrease the rate of combustion.

delta hinge. A designation for the flapping hinge of an articulated rotor blade. See ARTICULATED ROTOR (illus.), FLAPPING HINGE.

delta wing. A wing shaped in planform substantially like the Greek letter delta, or like an isosceles triangle, the base forming the trailing edge.

demand oxygen system. A system in which oxygen is supplied proportionally to demand during inhalation, the regulator being operated by pressure changes occurring during the breathing cycle. See PRESSURE-DEMAND OXYGEN SYSTEM.

density altitude. a. Calibrated pressure altitude (see PRESSURE ALTITUDE, sense 1a) corrected for existing free-air temperature. **b.** The altitude in a standard atmosphere corresponding to a given density actually encountered.

density ratio. The ratio of one density to another; specif., the ratio of the density of air at a given altitude to the air density at the same altitude in a standard atmosphere.

dep control. [After Armand *Déperdussin* (died 1924), French aviation pioneer.] A control system for airplanes in which the elevators and ailerons are operated by a control column and the rudder is operated by foot pressure on pedals or on a pivoted bar. This system is in use on a great many airplanes. See CONTROL COLUMN.

deplane, verb *intr.* To alight or descend from an airplane.—*tr.* To put off of an airplane.

deploy, verb *tr.* To release (a parachute) so as to let it fill out.—*intr.* Of a parachute: To unfold and fill out.

descend, verb *intr.* **1.** Of an aircraft: To come down, under control, from a higher to a lower altitude. **2.** To float down with a parachute.

design gross weight. The gross weight at take-off that an aircraft, rocket, etc. is expected to have, used in design calculations.

design load. A specified load that a structural member or part should with-

stand without failing. It is determined by multiplying some particular load by an appropriate factor, usually the limit load multiplied by a factor of safety.

detached shock wave, or detached shock. A shock wave not in contact with the body which originates it. See BOW WAVE, sense 1.

detonation, noun, 1. An explosion. **2.** Specif., in an internal-combustion piston engine, an abnormal, explosive combustion, either accompanying or replacing normal combustion, characterized by rough operation, increase of heat, and a knocking sound. Sometimes loosely called "knock." **3.** The phenomenon of the association of a shock wave with a rapid chemical reaction which releases sufficient energy to maintain the strength of the shock wave.

From the purist point of view, and for mathematical purposes, the phenomenon described in sense 2 is sometimes considered not to be detonation, the distinction between such a combustion or explosion and "actual" detonation being made in the behavior of shock waves in the two processes. The term "knock" has been proposed to signify the explosion taking place in the engine, as distinguished from "detonation," but "knock," used either in this sense or used synonymously with "detonation," is not satisfactory, for the term properly signifies a noise resulting from a detonation or explosion. See *Combustion, Flames and Explosions of Gases* by Bernard Lewis and Guenther von Elbe (New York: Academic Press, 1951), Chap. XI.

detonation wave. A shock wave in a combustible mixture, which originates as a combustion wave.

deviation, noun. The deflection of a compass needle or indicator from magnetic north as a result of local magnetic conditions.

diameter, noun. Specif., the length of a straight line passed across the circle described by a rotating propeller, rotor, or the like and through the center of rotation, measured between the points of intersection of the line with the circle; the dimension represented by this line between its points of intersection, as, a propeller eight feet in diameter. With a helicopter rotor, autogiro rotor, or the like, the blades in rotating are usually assumed rigid and at zero coning and lag angles. See ROOT DIAMETER, TIP DIAMETER.

diamond wing. A wing that in planform somewhat resembles a diamond or lozenge, but usually not symmetrical fore and aft.

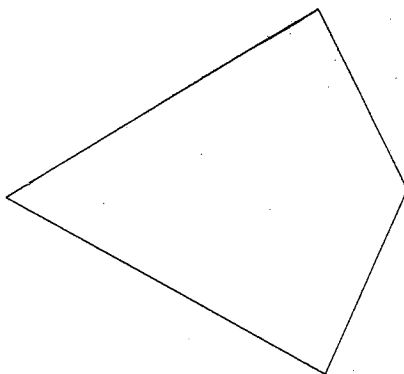

Planform of Diamond wing.

diaphragm, noun. 1. A thin dividing partition, as in a duct or chamber; an ANEROID. 2. A NOZZLE DIAPHRAGM.

A diaphragm is often flexible, and is used in certain instruments, regulators, or other devices to actuate mechanisms by means of pressure differences. See BURST DISK.

diesel cycle. [After Rudolf Diesel (1858-1913), German engineer.] An ideal cycle of operations for internal-combustion engines during which the working substance passes through adiabatic compression, constant-pressure heating, adiabatic expansion, and constant-volume exhaust.

diesel engine. A compression-ignition engine using fuel oil injected into the cylinder and which in its operation approximates the ideal diesel cycle.

differential ailerons. Ailerons geared so that, when they are deflected, the up aileron moves through a greater angle than the down aileron, used to reduce adverse yaw or to lessen the control force necessary for deflection.

diffuser, noun. A specially designed duct, chamber, or section, sometimes equipped with guide vanes, that decreases the velocity of a fluid, as air, and increases its pressure, as in a jet engine, a wind tunnel, etc. See SUBSONIC DIFFUSER, SUPERSONIC DIFFUSER.

diffuser efficiency. The efficiency with which a diffuser converts velocity energy into pressure energy, expressed, e. g., as the ratio of the actual pressure increase to the pressure increase that would take place if the process were isentropic.

diffuser, noun. Variant of "diffuser."

dihedral, noun. 1. a. The spanwise inclination of a wing or other surface,

such as a stabilizer, or of a part of a wing or other surface, to the horizontal, or to a line or plane equivalent to the horizontal; specif., a positive, or upward, inclination. Cf. ANHEDRAL. See also EFFECTIVE DIHEDRAL. b. DIHEDRAL ANGLE. 2. In a general sense, the inclination or angle between any two intersecting planes.

dihedral angle. The acute angle between two intersecting planes, or between lines representative of planes. Specif.: a. The acute angle between a line perpendicular to the plane of symmetry of an aircraft and a wing axis on either side of the plane of symmetry, projected to a plane perpendicular to the longitudinal axis of the aircraft. See EFFECTIVE DIHEDRAL. b. The acute angle between a line perpendicular to the plane of symmetry of an aircraft and a reference line in an airfoil, such as the root-to-tip axis of a stabilizer, projected to a plane perpendicular to the longitudinal axis of the aircraft.

With a wing axis or other reference line not substantially straight (e. g., as in a gull wing), the dihedral angle is measured for different straight-line segments of the axis or line.

All angles are considered positive if the wing or other airfoil slants upward from root to tip, or in the direction of lift: "dihedral angle" is sometimes restricted to such an angle of positive sign: cf. ANHEDRAL ANGLE.

dihedral effect. a. An effect due to dihedral. b. The rolling moment of an aircraft due to sideslip, resulting from whatever causes, but resulting principally from the actual dihedral of the wing or wings. The dihedral effect is said to be positive if it is such that it tends to raise the forward wing in the sideslip.

direct control. The control exercised over the rotor of a rotary-wing aircraft by tilting the rotor hub. Used esp. with autogiros.

direct drive. Drive with a direct, i. e., transmissionless, connection.

—direct-drive, *adj.*, as in direct-drive engine, an engine with its drive shaft connected directly to the propeller, direct-drive propeller, a propeller so driven.

directional balance. The balance (which see, sense 1) of an aircraft, rocket, etc. with respect to its vertical axis.

directional control. Control of motion about the vertical axis; in aircraft, usually by rudder.

directional gyro. 1. A flight instrument incorporating a gyroscope that holds its position in azimuth and so indicates angular deviation from heading. 2. A gyroscope that provides directional stability in an automatic pilot or similar mechanism.

directional stability. The property of an aircraft, rocket, etc. enabling it to restore itself from a yawing or sideslipping condition. Also called "weathercock stability."

direction finder. A RADIO DIRECTION-FINDER.

dirigible, noun. An airship.

dirigible, adj. That can be directed or guided.

disc, noun. Variant of "disk."

The spelling "disc" is frequently used, both by itself and in compounds, as in actuator disc, disc area, disc loading, propeller disc, and rotor disc.

dischargeable weight. On an airship, all weight that can be, or is, discharged or consumed with the ship remaining in safe operating condition. The dischargeable weight includes the weight of fuel and oil (except reserve), ballast (except emergency), provisions, and other weight as may be defined in specific context.

dish antenna. A radar antenna having a paraboloid reflector.

dishpan, noun. A PROPELLER AFTERBODY. *Slang.*

disk, noun. [See DISC and note.] 1. A rotating propeller or rotor, regarded as a plane, circular surface; the plane, circular area described by the blade tips of a rotating rotor or propeller. Sometimes called respectively a "propeller disk" or "rotor disk." See ACTUATOR DISK. 2. A circular plate or piece. See ROTOR DISK, sense 2.

disk area. The area of the circle described by the blade tips of a rotating propeller or rotor.

disk loading. The unit load sustained by a rotor disk of a rotary-wing aircraft, determined by dividing the gross weight of the aircraft by the disk area.

displacement thickness. In the study of fluid flow, a measure of the deficiency of mass flow in a boundary layer, indicating the amount that a streamline outside the boundary layer is displaced by the boundary layer. The displacement thickness, δ^* , may be defined by the equation

$$\delta^* = \int_0^\delta \left(1 - \frac{\rho u}{\rho_0 U}\right) dy,$$

where δ = boundary-layer thickness, ρ = local fluid density inside boundary layer, u = local velocity inside boundary layer, ρ_0 = local fluid density at edge of boundary layer, U = local velocity at edge of boundary layer, and y = distance normal to surface. (For incompressible flow, $\rho = \rho_0$.)

disposable load. Same as USEFUL LOAD (in sense 1).

dissociation, noun. In a combustion process, as in a rocket engine, a decomposition of the combustion products.

dissymmetry of lift. The unequal or asymmetric distribution of lift; specif., the unequal lift across the rotor disk of a rotary-wing aircraft, owing to the difference in wind velocity over the advancing and the retreating blades.

distance-measuring equipment. Electronic navigation equipment for finding the distance between an aircraft and a ground station by measuring the time interval between the transmission of interrogation pulses from an airborne radar and the reception of answering pulses from a transponder at the ground station.

distant-indicating, adj. Same as REMOTE-INDICATING.

ditch, verb. 1. *tr.* To set (an aircraft) down upon water, deliberately and under emergency conditions, such as when the aircraft suffers mechanical failure, has insufficient fuel, or is otherwise unable to reach, or alight safely at, a landing place—the word commonly implies abandonment and loss of the aircraft in the water. 2. *intr.* Of an aircraft or persons within: To make a forced landing on water and (of persons) to abandon the aircraft.

ditching, noun. An act or instance of making a forced landing on water with subsequent abandonment of the aircraft. See FORCED LANDING.

dive, noun. 1. An act or instance of an aircraft descending nose downward, its longitudinal axis remaining substantially coincident with its line of flight. Cf. GLIDE, *noun*, sense 1. 2. A descending flight path of a dive, as, to enter a dive, or, a steep dive.

dive, verb. 1. *intr.* Of an aircraft or persons within: To make a dive. 2. *tr.* To put into a dive.

dive brake. An air brake designed esp. to slow down an airplane in a dive. A dive brake normally consists of a flap, plate, or the like located in the wing or fuselage. See AIR BRAKE, sense 1.

dive flap. A flap-type dive brake or a dive-recovery flap.

dive-recovery flap. A flap, usually located on the underside of a wing or fuselage, used to assist in, or to enable, pulling out of a dive.

diving angle. The angle between the horizontal and the flight path of a diving airplane.

diving moment. A moment tending to nose an aircraft down.

D layer. A term applied to a layer of concentrated ionization in the ionosphere that exists in the region between altitudes of about 35 and 50 miles.

DME—Abbreviation for *distance-measuring equipment*.

dock, noun. 1. A building, scaffold, or place set up for the inspection, maintenance, or repair of aircraft. 2. An AIRSHIP HANGAR.

dock, verb tr. To haul or put (an aircraft) into a dock.

dog-leg course. A bent course, i. e., a course abruptly departing from a straight line.

dope, noun. 1. A liquid substance applied to aircraft fabric coverings which dries to tighten the fabric, improve airtightness, increase strength, etc. 2. Any additive (which see) for gasoline used to reduce detonation. Called more specifically "fuel dope."

dorsal, adj. Mounted on, or belonging to, the back (which see) of an aircraft, as in *dorsal fillet, dorsal fin, dorsal stringer, dorsal turret*. Cf. VENTRAL.

double-acting engine. A reciprocating engine in which the gas or other working substance acts upon each end of the piston alternately. See CAM ENGINE (illus.).

double-base propellant. A solid rocket propellant based on two substances, such as nitrocellulose and nitroglycerin.

double-delta wing. A wing shaped in planform like two triangles, the forward part of one triangle being replaced by a triangle of lesser apex angle.

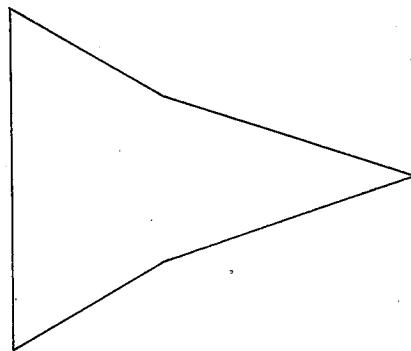

Planform of Double-delta wing.

double-drift method. A method of determining, in flight, the speed and direction of the wind by observing the drift angle on two headings at approximately right angles to each other, or sometimes on two such headings and the original heading.

double-entry compressor. A centrifugal compressor that takes in air or fluid on both sides of the impeller, vanes on each side of the impeller accelerating the fluid into the diffuser. The double-entry compressor is not a multistage compressor.

double monoplane. An early form of airplane, such as the Langley aerodrome, having two wings placed in tandem.

double-slotted flap. A flap consisting of two sections jointed together, providing two slots for the passage of air.

doublet, noun. A source and a sink of equal strength whose distance apart is zero. See SINK, *noun*, sense 1, SOURCE.

double-wedge airfoil. An airfoil profile usually having the shape of a slim rhombus with maximum thickness at mid-chord point; however maximum thickness can also occur at other chord locations.

downflow, noun. A flow downward; DOWNWASH.

down lock. A locking device that holds a retractable landing gear in the extended position.

downwash, noun. A flow deflected or forced downward, as by the passage of a wing or by the action of a rotor or rotor blade. Cf. UPWASH.

downwash angle. The angle, measured in a plane parallel to the plane of symmetry of an aircraft, between the direction of downwash and the direction of the undisturbed airstream. This angle is positive when the deflected stream is downward. Cf. UPWASH ANGLE.

Drachen, noun. [German, "dragon"; also "kite," from the resemblance of the early Chinese kite to a dragon.] An early form of kite balloon developed in Germany and used in WW I, consisting principally of a cylindrical body with hemispherical ends, a single air-filled stabilizing lobe, and a stabilizing tail of air cups. See KITE BALLOON.

draft, noun. 1. *Meteorol.* An orderly, large-scale flow of atmospheric air in a generally vertical direction, having a velocity insufficient to cause significant loads on the structure of an aircraft encountering it. 2. The depth to which a ship, seaplane float or hull, etc. is submerged under stated conditions of loading, measured from the water line to the lowest point of the body.

drag, noun. 1. A retarding force acting upon a body in motion through a fluid, parallel to the direction of motion of the body. It is a component of the total fluid forces acting on the body. 2. The effect of this force, as, to reduce the *drag* of an aircraft.

Drag has been analyzed and classified into several different kinds; these are *form drag, friction drag, induced drag, parasite drag, pressure drag, profile drag, and wave drag*. (See individual entries on these terms.) In occasional distinctions, "drag" is modified by a word identifying the body or component with which it is associated, as in *fuselage drag, nacelle drag, rotor drag, or tail drag*. See WING DRAG; also see COOLING DRAG, RAM DRAG, TARE DRAG.

drag, verb tr. To fly low over (an airfield or other place) to make an examination, usually preparatory to landing. *Colloq.*

drag angle. Same as LAG ANGLE.

drag brake. Same as SPEED BRAKE.

drag chute. Short for DRAG PARACHUTE.

drag coefficient. A coefficient representing the drag on a given airfoil or other body, or a coefficient representing a particular kind of drag.

The drag coefficient is obtained by dividing the drag by the product of the free-stream dynamic pressure and by the representative area of the body under consideration. The drag coefficient varies with speed and angle of attack.

drag component, or drag force. A component of the total dynamic forces on a body moving in a fluid, acting parallel to the direction of motion and opposing the motion. See DRAG, *noun*, sense 1.

drag hinge. The hinge about which an articulated rotor blade trails or advances in its plane of rotation; a hinge that permits a back-and-forth movement of a rotor blade. Also called a "lag hinge." See ARTICULATED ROTOR (illus.).

drag link. Specif., an adjustable rod or bar between the blade and hub of certain two-blade rotors, used to maintain the angular spacing between the blades.

drag parachute. Same as DROGUE PARACHUTE.

drag rope. A rope hung overboard from a balloon or airship and dragged on the ground, used as a brake or variable ballast, esp. during landing, or as an aid in steering. Sometimes called a "guide rope" or "trail rope."

drag rudder. A device used to create a drag on one side or other of an aircraft to provide directional control. Drag rudders may be used, e. g., at the wing tips of a tailless airplane.

drag stop. A limit stop used in the rotor of a rotary-wing aircraft to prevent excessive horizontal movement of a blade. See LIMIT STOP.

drag strut. Any strut used to resist drag or antdrag forces, as: a. A fore-and-aft member in a wing or airfoil structure, introduced esp. to resist drag or antdrag forces. b. In a retractable landing gear, a strut which, when the gear is in the extended position, runs diagonally upward into the aircraft, resisting forces acting in the direction of drag.

drag truss. A truss between the spars of a wing or other airfoil to resist drag and antdrag forces.

drag wire. A wire in certain kinds of wing structures, running from a forward inboard point to an aft outboard point, used to resist drag forces. Cf. ANTIDRAG WIRE.

drift, noun. 1. The lateral divergence or movement of the flight path of an air-

craft, rocket, or the like from the direction of its heading, measured between the heading and the track, owing primarily to the effect of a cross wind; also, a DRIFT ANGLE. 2. The rate of drift, as, a *drift* of two knots. 3. The horizontal movement of a parachute and its burden through the air, measured from the moment the parachute is fully inflated until the surface is touched; the amount of this movement. 4. As used by the Wrights and others, INDUCED DRAG. *Obs.*

drift angle. An angle measured from the heading of an aircraft, rocket, etc., to its track. Cf. DRIFT CORRECTION ANGLE.

drift correction angle. A measure of the amount of turning necessary to make the track of an aircraft, rocket, etc., coincide with its course, measured from the track to the heading.

drift indicator. Same as DRIFT METER.

drift meter, or driftmeter, noun. A navigation instrument for measuring the drift angle of an aircraft by reference to points on the earth's surface.

drift sight. Same as DRIFT METER.

D-ring, noun. A D-shaped metal ring, used, e. g., to connect the harness of a parachute to the shroud lines.

drogue, noun. 1. A device, usually shaped similarly to a funnel or cone, dragged or towed behind something and used, e. g., as a sea anchor. 2. *Specif.:* a. A funnel-shaped part at the end of the hose of a tanker aircraft, used in air refueling to drag the hose out and stabilize it and to receive the probe of the receiving aircraft. b. A DROGUE PARACHUTE.

drogue parachute. A type of parachute attached, e. g., to an ejection cockpit or seat, used to slow it down in falling; a DECELERATION PARACHUTE.

Also called a "drag parachute."

drone, noun. A pilotless, remote-controlled aircraft, often a conventional man-carrying aircraft modified for unmanned operation. Used esp. as a target aircraft in gunnery practice.

droop flap. A flap at the leading edge of a wing, deflected downward to improve stalling characteristics.

droop snoot. 1. An airplane nose that can be deflected downward to improve

the pilot's visibility, esp. in landing. *Slang.* 2. A DROOP FLAP. *Slang.*

droop stop. A device incorporated in a rotor to limit the downward inclination of the blade at rest. See LIMIT STOP.

droppable, adj. That can be dropped from an aircraft in flight, as in *droppable* fuel tank, *droppable* lifeboat, *droppable* pod, a pod or section of an aircraft that can be detached and parachuted or glided to earth.

dropsonde, noun. A radiosonde equipped with a parachute, dropped from an aircraft to transmit measurements of atmospheric conditions as it descends.

drop tank. A tank that can be detached and dropped in flight. See DROPPABLE.

drop test. A test of something by dropping it or by dropping something on it, such as a test to prove the serviceability of a parachute by dropping it with a dummy, or a strength test of a landing gear by letting it fall and strike with force.

dry weight. *Specif.,* the weight of an engine exclusive of any liquids it carries, as fuel, oil, coolant, or oxidant.

dual control. 1. The control provided by a double set of cockpit controls in an aircraft. 2. *In plural.* A double set of aircraft controls.

dual instruction. Pilot instruction in which the student flies with the instructor and is allowed to operate the aircraft with one of the sets of dual controls.

dual-rotation propeller, or dual-rotation propellers. A less precise term for CONTRAROTATING PROPELLER (in sense 1 or sense 2). See TANDEM PROPELLERS.

duct, noun. A tube or passage that confines and conducts a fluid, as a passage for the flow of air to the compressor of a gas-turbine engine, a pipe leading air to a supercharger, etc. See D-DUCT.

ducted fan. 1. A fan (which see) enclosed in a duct. 2. *Also, less frequently, ducted-fan engine.* An aircraft engine incorporating a fan or propeller enclosed in a duct; esp., a jet engine in which a ducted fan or ducted propeller is used to take in air to augment the gases of combustion in the jet stream. The air may be taken in at the front of the engine and passed around the combustion section, or it

may be taken in aft of the combustion chamber or chambers. In the former case it may be considered a type of bypass engine. See BYPASS ENGINE.

ducted ogive. An ogival body of revolution ducted from end to end, the pointed or rounded nose being replaced by an inlet.

ducted propeller. A propeller enclosed within a duct, the duct serving to prevent radial losses at the propeller-blade tips; also, a ducted fan used in a bypass or ducted-fan engine. See FAN, sense 1b.

ducted rocket. 1. A rocket mounted in a duct. 2. A ROCKET RAMJET.

dump valve. A valve for rapidly draining fluid from a container or system, as in an aircraft for jettisoning fuel or ballast in an emergency.

Dutch roll. A complex oscillating motion of an aircraft involving rolling, yawing, and sideslipping. So named from the resemblance to the characteristic rhythm of an ice skater.

dye marker. A substance which, when placed in water, spreads out and colors the water immediately surrounding so as to make a spot readily visible from the air. It is used, e. g., by persons forced down at sea.

dynamic, adj. Of or pertaining to dynamics, esp. to aerodynamics. See AERODYNAMIC.

dynamic lift. Lift derived dynamically, esp. aerodynamically. See AERODYNAMIC LIFT.

dynamic load. A load imposed by dynamic action—disting. from a STATIC LOAD; more technically, with respect to aircraft, a load due to an acceleration of an aircraft, as imposed by gusts, by maneuvering, by landing, by firing aircraft armament, etc. See AERODYNAMIC LOAD.

dynamic model. A model of an aircraft or other object, as a bomb, having its linear dimensions and its weight and moments of inertia reproduced in scale in proportion to the original.

dynamic pitch. Same as ZERO-THRUST PITCH.

dynamic pressure. The pressure of a fluid resulting from its motion, equal to one half the fluid density times the fluid velocity squared ($\frac{1}{2}\rho V^2$). In in-

compressible flow, dynamic pressure is the difference between total pressure and static pressure. See IMPACT PRESSURE.

dynamic scale. The scale of the flow about a model relative to a flow about its prototype. If two such flows have the same Reynolds number, both flows are said to be at the same dynamic scale.

dynamic similarity. The relationship existing between a model and its prototype when, by virtue of similarity between their geometric dimensions and mass distributions, the motion of the model in some respect (such as linear velocity, acceleration, etc.) is similar to the motion of the prototype; also, the similarity between the fluid flows about a scale model and its prototype when the flows have the same Reynolds number. See REYNOLDS NUMBER.

dynamic stability. The property of a body, such as an aircraft or rocket, that causes it, when disturbed from an original state of steady flight or motion, to damp the oscillations set up by restoring moments and gradually return to its original state.

dynamic suspension. The suspension of an engine-propeller unit in an aircraft by a number of rubber-mounted links conically disposed about the engine with their axes converging near the unit's center of gravity, thus isolating most of the unit's vibration from the airframe.

dynamic trim. *Specif.,* the trim of an airship when subjected to aerodynamic forces and propeller thrust.

dynamometer, noun. An instrument for measuring power or force; *specif.,* an instrument for measuring the power, torque, or thrust of an aircraft engine or rocket. See HUB DYNAMOMETER, THRUST METER.

dynamotor, noun. A machine combining motor and generator action in a single magnetic field, either with two armatures or with one armature having two separate windings.

dysbarism, noun. Med. A sickness, such as aeroembolism or sinusitis, brought on by a pressure difference between the ambient pressure and the pressure of dissolved and free gases in the body.

E

earth axis. Any one of a set of mutually perpendicular reference axes established with the upright axis (the Z-axis) pointing to the center of the earth, used in describing the position or performance of an aircraft or other body in flight. The earth axes may remain fixed or may move with the aircraft or other object.

earth-inductor compass. In a general sense, a compass that depends for its indications upon a current generated by a coil or coils turned or rotated in the earth's magnetic field; *specif.*, a compass of this type, now generally obsolete, utilizing a single coil, commonly wind-driven, spinning in the earth's magnetic field.

In the general sense, a gyro flux gate compass is considered a form of earth-inductor compass.

echo, noun. In radar, a pulse of reflected radio-frequency energy.

economizer, noun. A valve or regulator that meters a flow in a system to minimum quantities in accordance with demand; *specif.*, a carburetor valve that remains closed at lower powers, but that opens to enrich the fuel-air mixture when the power demand increases.

economy cruise. The cruise of an aircraft operated so as to achieve the most economical flight in terms of fuel consumption. See CRUISE CONTROL.

ecosphere, noun. [Greek *oiko-*, from *oikos* ("house," "habitat") + *sphere*.] *Av. med.* That part of the atmosphere in which normal breathing is possible, extending to an altitude of about 13,000 feet above sea level.

eddy, noun. A region of undirected or swirling flow, as in the flow of air about or behind a body; a vortex.

Used in self-explanatory compounds, such as eddy motion, eddy resistance, eddy shearing stress.

eddy current. 1. A current characterized by an eddy or eddies. 2. *Electricity.* A local electric current induced and fully contained within a mass of metal, as in the core of an armature.

effective angle of attack. The difference between the geometric angle of attack and induced angle of attack. (For finite airfoils, the direction of the

wind is a resultant direction, i. e., the direction of the relative wind with induced effects present.)

The effective angle of attack is the same as a geometric angle of attack in two-dimensional flow, i. e., the same as the angle of attack for infinite aspect ratio. See ANGLE OF ATTACK FOR INFINITE ASPECT RATIO.

effective aspect ratio. The aspect ratio of a hypothetical airfoil of elliptical planform having the same induced drag at a given lift coefficient as the actual airfoil or combination of airfoils under consideration.

effective dihedral. A quality or combination of qualities that provides the dihedral effect for an aircraft. The effective dihedral may provide a greater or lesser dihedral effect than the actual wing dihedral would be expected to provide. See DIHEDRAL EFFECT, sense b.

effective dihedral angle. The imaginary angle of the effective dihedral (which see), that would be required to produce the dihedral effect actually obtained.

effective exhaust velocity. A fictitious exhaust velocity that would give the same jet thrust as that actually obtained.

The effective exhaust velocity is determined by the equation

$$V_e = V + \frac{A(p_1 - p_2)g}{w}$$

where V is the velocity of the exhaust gases, A is the nozzle exit area, p_1 is static pressure at the nozzle exit, p_2 is ambient pressure, g is the acceleration of gravity, and w is the weight flow rate of exhaust gases.

effective pitch. 1. The actual distance a propeller advances in the direction of the flight path in one revolution. This is the geometric pitch less the distance loss due to slip. 2. Same as EXPERIMENTAL PITCH; also, loosely, same as ZERO-THRUST PITCH (i. e., the mean experimental pitch). *Rare.*

effective propeller thrust. The actual driving force exerted by a propeller minus any increase in airplane drag owing to the propeller itself.

effective Reynolds number. A fictitious Reynolds number applied to the flow of air about a body in a wind tunnel, equal to the free-air Reynolds number at which the effect obtained is the same as the effect obtained in the wind tunnel.

For example, if a flow separation is obtained about a body at a Reynolds number of 1,000,000 in outside air, and obtained about the same or a similar body at a Reynolds number of 800,000 in a wind tunnel, the effective Reynolds number of the flow in the wind tunnel is 1,000,000. It is found by multiplying the actual Reynolds number of the flow in the tunnel by the turbulence factor of the tunnel.

effective span. The span of an airfoil less corrections for tip loss.

effuser, noun. A specially designed duct for increasing the velocity of a flow.

effuser, noun. Variant of "effuser."

eggbeater, noun. A helicopter; *specif.*, a helicopter with intermeshing rotors. *Slang.*

eight, noun. A flight performance or maneuver in which an airplane describes a flight path shaped like, or suggestive of, a figure eight; the flight path so described, either in the horizontal or vertical plane.

—eight across a road, a horizontal eight in which the two loops of the figure are on opposite sides of a road below; eight around pylons, an eight in which the two loops or circles of the figure are traced around a pair of pylons on the ground; eight on pylons, a type of eight around pylons in which the inner wing tip of the airplane remains pointed at each pylon as the airplane banks around it.

See CURVE EIGHT, FOUR-BANK EIGHT, LAZY EIGHT. Also see FIGURE EIGHT.

ejection capsule. A detachable compartment serving as a cockpit or cabin of an airplane, which may be ejected as a unit and parachuted to the ground.

ejection seat. An airplane seat designed to be catapulted with its occupant from the airplane, usually by explosive force. Sometimes called an "ejector seat."

ejector, noun. *Specif.*, a device consisting of a nozzle, a mixing space, and a diffuser, utilizing the kinetic energy of a fluid stream to pump or draw another fluid from a region of low pressure by direct mixture and ejecting both fluid streams.

ejector seat. Same as EJECTION SEAT.

elastic axis. A line or axis in a structure or member, such as a wing, about which torsional deflection occurs when a torque is applied. It is made up of the elastic centers of the structure or member.

elastic center. A point within a section of a structure or member, such as an airfoil section, at which the application of a load will cause lengthwise or spanwise deflection but not torsional deflection, hence, a point in a section about which torsional deflection occurs.

elasticizer, noun. An elastic substance or fuel used in a solid rocket propellant, esp. to prevent cracking of the propellant grain and to bind it to the combustion-chamber case.

E layer. A term applied to a layer of concentrated ionization in the ionosphere that exists in the region between altitudes of about 50 and 90 miles.

electric propeller. A propeller whose blade angle is regulated by an electric motor.

electric tachometer. A tachometer that utilizes voltage or electrical impulses to indicate rpm; *specif.*, a tachometer that utilizes the voltage output of a generator driven by the engine to indicate rpm, the voltage output being directly proportional to the rotational speed of the rotary element in the generator, and hence to the rotational speed of the engine driving it. Cf. MECHANICAL TACHOMETER.

electronic, adj. Of or pertaining to electronics, i. e., to that branch of physics that treats of the emission, transmission, behavior, and effects of electrons, esp. as applied by means of vacuum tubes, cathode-ray tubes, photoelectric cells, and the like, together with the associated electrical devices, and thus embracing the fields of radio, radar, and television. *Specif.*: a. Done, assisted, or accomplished by means of electronics, or by radio, radar, or television apparatus, as in *electronic amplification*, *electronic control*, *electronic navigation*. b. Utilizing electronics, or utilizing or consisting of vacuum tubes, cathode-ray tubes, etc. and associated electrical devices, as in *electronic automatic pilot*, *electronic computer*, *electronic instrument*. c. Established by, or consisting of, electrons, as in *electronic circuit*, *electronic field*, *electronic flow*.

element, noun. *Specif.*, a BLADE ELEMENT.

elerudder, noun. Same as RUDDERVATOR.

elevation, noun. Height or altitude above the surface of the earth or other datum plane; also, the ANGLE OF ELEVATION.

elevation angle. Same as ANGLE OF ELEVATION.

elevation head. The unit energy a fluid has owing to its elevation. See HEAD, sense 2.

elevator, noun. A control surface, usually hinged to a horizontal stabilizer, deflected to impress a pitching moment, i. e., to make the aircraft or other flying body of which it is a part to rotate about its lateral axis. An elevator may be one of a pair, each one of the pair being situated to either side of the center line (hence the frequent use of the plural, "elevators"), or it may be a continuous surface running from end to end of the stabilizer.

This word is frequently used in compounds (mostly self-explanatory), some of which follow: elevator cable, elevator control, elevator control wheel (on certain airships), elevator deflection, elevator effectiveness, elevator hinge moment, elevator horn (see CONTROL HORN), elevator position indicator, elevator surface, elevator trim tab.

elevator angle. The angular displacement of an elevator from its neutral position. This angle is positive when the trailing edge of the elevator is below the neutral position.

elevator booster. A control booster for an elevator or elevators. See CONTROL BOOSTER.

elevon, noun. [*Elevator*+*aileron*.] A control surface that functions both as an elevator and as an aileron. Also called an "aillevator" or "ailelevator."

elliptic lift distribution. A lift distribution along an airfoil in which the lift decreases progressively along the span from the center of the wing to the tips, a plot of lift per unit length against unit distance along the span having the shape of an ellipse.

emergency, noun. Used attributively to denote that which is used or done in abnormal circumstances, as in *emergency* airfield, *emergency* air pressure line, *emergency* ballast (fuel or other substance or objects not normally used as ballast), *emergency* canopy release, *emergency* flotation gear (gear used with a landplane to provide buoyancy for an emergency landing on water), *emergency* hatch (see ESCAPE HATCH), *emergency* landing, *emergency* oxygen equipment, *emergency* parachute (see CHEST-PACK PARACHUTE), *emergency* power, *emergency* release, etc.

empennage, noun. [French, "feathering of an arrow" (*penne*, "feather").] Pronunciation now semi-Anglicized, first syllable pronounced "em," but last syllable pronounced "nahzh" (*zh* sound as in "measure"), and bear-

ing the primary accent.] The assembly of stabilizing and control surfaces at the tail of an aircraft; on a kite balloon, the assembly of stabilizing lobes or surfaces at the tail.

Also called a "tail group." Cf. TAIL ASSEMBLY.

empty weight. The weight of an aircraft including the weight of its power plant, trapped fuel and oil, coolant (if any), fluid in the hydraulic system, ballast normally carried, fixed equipment and furnishings, and other weight as may be defined in context; also sometimes applied to a rocket less the weight of its propellants and load.

This term is subject to special definition. It has particular significance in contract specifications.

end-fire array. A linear or cylindrical antenna arrangement having its direction of maximum radiation parallel to the long axis of the array.

end gas. The yet-unburned portion of the burning fuel-air mixture in an engine cylinder—usually applied to a small remaining portion.

end load. Same as AXIAL LOAD.

end plate. Also *endplate, noun.* A plate or surface at the end of an airfoil, attached in a plane substantially normal to that of the airfoil and parallel to the direction of flight, that inhibits the formation of a tip vortex and thus produces an effect similar to that of increased aspect ratio.

endurance, noun. Specif.: 1. a. The length of time that an aircraft can fly under specified conditions without refueling. b. The length of time an engine can operate under specified conditions, sometimes on a given amount of fuel or propellant. 2. The capability of an aircraft or engine as measured or judged by this length of time, as, an airplane with good *endurance*.

energy conversion efficiency. The efficiency with which a nozzle converts the energy of the working substance into kinetic energy, expressed as the ratio of the kinetic energy of the jet leaving the nozzle to the kinetic energy of a hypothetical ideal jet leaving an ideal nozzle using the same working substance at the same initial state and under the same conditions of velocity and expansion.

energy ratio. The ratio of the kinetic energy per unit time of the fluid in the

test section or jet of a wind tunnel to the input energy per unit time required to maintain the flow in the tunnel.

The input energy used to find the energy ratio may be the input energy into the fluid (tunnel energy ratio), the input energy into the electric motors (input energy ratio), or the input energy into the fan (fan energy ratio).

engine, noun. A machine or apparatus that converts energy, esp. heat energy, into work; an aircraft engine (which see).

Engines used in aircraft can be classified under three general types, with some overlapping, as follows: (1) *reciprocating engine* (internal-combustion), (2) *gas-turbine engine*, and (3) *reaction engine*. (See individual entries on these types.)

The word "engine," unqualified as to type, often means "internal-combustion reciprocating engine," esp. in certain compounds: see, e. g., TWIN-ENGINE.

See CHEMICAL ENGINE, EXTERNAL-COMBUSTION ENGINE, HEAT ENGINE, INTERNAL-COMBUSTION ENGINE, LEFT-HAND ENGINE, PUSHER ENGINE, RIGHT-HAND ENGINE, TRACTOR ENGINE.

In self-explanatory compounds, as follows: engine cooling system, engine cowl, engine cylinder, engine-driven, *adj.*, engine exhaust pressure, engine failure, engine horsepower, engine knock, engine mount, engine oil system, engine performance, engine test stand, engine throttle, engine thrust, engine torque, etc.

See MOTOR and note.

engine accessory. An accessory (which see) that contributes to the operation of an engine.

Engine accessories are not essential to the identity of an engine as such, but include many that are essential to the operation or running of the engine. Engine accessories commonly include carburetors, fuel and oil pumps, magnetos, spark plugs, starters, superchargers, ignition systems, and other articles or apparatus not considered an integral part of the engine.

engine analyzer. A device or indicator, incorporating a cathode-ray tube, that detects and indicates ignition malfunctions and other malfunctions in an engine, such as detonation, sticky valves, etc.

engine baffle. A PRESSURE BAFFLE.

engine car. Same as POWER CAR.

engine control. Any control for regulating the power and speed of an engine, such as the throttle, mixture control, manifold-pressure regulator, fuel-pressure control, supercharger control, etc.

engine cowling. A cowling placed around an aircraft engine for directing and regulating a flow of cooling air, for streamlining, or for protection. See NACA COWLING, RING COWLING.

engine displacement. Same as PISTON DISPLACEMENT.

engine dry weight. The dry weight of an engine. See DRY WEIGHT.

engine-exhaust condensation trail. A type of condensation trail arising from the engine exhaust. See CONDENSATION TRAIL and note.

engine gauge unit. A combination engine instrument containing a fuel pressure gauge, an oil pressure gauge, and either an oil temperature gauge or a coolant temperature gauge in a single case.

engine instrument. An instrument that provides information regarding the operation or performance of an aircraft engine or of its accessories and associated equipment. Engine instruments include oil and fuel pressure gauges, manifold-pressure gauges, tachometers, torque meters, fuel-quantity gauges, fuel flowmeters, voltmeters, engine synchronizers, etc. See AIRCRAFT INSTRUMENT.

engine nacelle. A nacelle for housing an engine and its accessories. See ENGINE POD.

engine pod. A streamlined structure or nacelle on an airplane, usually slung beneath the wing or attached to the wing tip, housing one or more jet engines. See ENGINE NACELLE.

engine weight per horsepower. The dry weight of an engine divided by its rated horsepower.

enplane, verb intr. To go aboard an airplane to make a trip.—*tr.* To put aboard an airplane.

en route. Sometimes *enroute*. [Pronounced "ahn root" or "in root."] On or along a route—used adjectivally, as in *en route* refueling; also adverbially, as, to delay *enroute*.

entrance cone. The conelike portion of a wind tunnel, or a nozzle, that leads the flow to the test section. See SETTLING CHAMBER (illus.).

envelope, noun. Specif., a covering, or something that envelops; specif., the gasbag of a pressure airship or of a balloon, or the outer covering of a rigid airship. See FLIGHT ENVELOPE.

equipotential surface. A surface or plane passing through all points having the same potential in a field of flow.

equisignal beacon. A radio beacon that transmits patterns creating one or more equisignal zones.

A localiser or the beacon in an Adcock or loop-type radio range is an equisignal beacon.

equisignal zone. A zone, narrow in azimuth, lying within two overlapping signal patterns transmitted by radio, in which two signals are received with equal intensity, and which defines the course or direction toward the radio-transmitting station. The equisignal zone is manifested aurally as a steady hum in the earphones, formed by the merging of the two signals. See LOOP-TYPE RADIO RANGE.

equivalent airspeed. The speed under standard sea-level conditions that produces a dynamic air pressure equivalent to the dynamic air pressure produced at some speed at a given altitude, i. e., a calibrated airspeed corrected for the effect of compression of air in the pitot system.

equivalent blade chord. An average chord for a rotor blade of nonrectangular planform, equal to the chord of a rectangular blade having or yielding the same thrust or torque as the actual blade. Used in calculating the solidity of a rotor.

equivalent flat-plate area. The area of a hypothetical square, flat plate which, if placed perpendicular to the direction of motion in a field of flow, would offer the same amount of aerodynamic resistance to motion as the body or combination of bodies under consideration.

equivalent monoplane wing. A hypothetical monoplane wing equivalent in lift and drag properties to the combined wings of a given biplane or triplane.

equivalent oxygen altitude. An altitude having the same amount of oxygen as that in an altitude chamber or in a breathing system.

equivalent shaft horsepower. The shaft horsepower of a turbopropeller engine plus an additional power which if applied to the shaft would produce a propeller thrust equal to the jet thrust of the engine.

For the static condition, the equivalent shaft horsepower may be defined by the equation $E\text{SHP} = \text{SHP} + \frac{F}{2.5}$ where F is the jet thrust in pounds and 2.5 represents the typical amount of propeller thrust, in pounds, per shaft horsepower.

erect, verb tr. Specif., to inflate (a balloon or airship) with gas.

escape hatch. A hatch in an aircraft intended esp. for use in abandoning the aircraft.

E-scope, noun. A radarscope that presents the range of an object by a horizontal displacement of the signal spot and its elevation by a vertical displacement.

estimated time of arrival. The predicted time at which an aircraft in flight will reach some point, usually its destination.

ETA—Abbreviation for *estimated time of arrival*.

excess buoyancy. The buoyancy in excess of the amount needed to equalize the weight of a body and the fluid displaced by it. With a seaplane float, it represents the difference between the weight of the water displaced by the float when completely submerged and the weight of the water displaced by the float when submerged to the water line at which it supports, or helps to support, the normal gross load of an airplane. Also called "reserve buoyancy."

excrecence, noun. A projection or projecting component, such as a turret, blister, landing-gear wheel, etc., on an aircraft or similar body.

Used in compounds, such as *excrecence drag* (see *DRAG, noun, note*).

executive aircraft. A passenger airplane or small transport designed esp. for the use of business executives. Also *collective*.

exhaust back pressure. The pressure exerted in the cylinder or cylinders of an engine by the exhaust gases, caused by the resistance met by the gases as they leave the cylinders.

exhaust collector ring. A circular manifold which collects the exhaust from the cylinders of a radial engine.

exhaust cone. An assembly at the back end of a gas-turbine engine, consisting of a cone-shaped inner part (the *inner cone*) surrounded by a casing shaped like a truncated cone (the *outer cone*), the jet exhaust being conducted through the space between the two pieces. Also called a "tail cone" (which see).

exhaust-gas analyzer. An engine instrument that analyzes the composition of exhaust gases from an engine to indicate the fuel-air ratio of the mixture the engine is burning or to determine combustion efficiency.

exhaust moisture condensation trail. Same as *ENGINE-EXHAUST CONDENSATION TRAIL*.

exhaust nozzle. A nozzle through which exhaust gases are ejected, as from a jet or rocket engine.

See *FIXED-AREA EXHAUST NOZZLE, IRIS-TYPE NOZZLE, VARIABLE-AREA EXHAUST NOZZLE*.

exhaust stack. A pipe, usually a short pipe, for leading exhaust gases from an engine cylinder and discharging them, ordinarily, into the open. See *JET STACK*.

exhaust stroke. In a four-stroke-cycle engine, the stroke or movement of the piston that pushes the exhaust gases out of the cylinder.

exit cone. The conelike portion of a wind tunnel through which the flow exits from the test section.

exosphere, noun. [Greek *εξω* ("outside") + *sphere*.] The outermost layer of the atmosphere. The term is subject to different definition and understanding according to context.

expansion ratio. 1. The ratio of a volume before expansion to the volume after expansion, as in an engine cylinder. Cf. *COMPRESSION RATIO*. 2. The area ratio of an expanded duct or nozzle, as a rocket nozzle. See *AREA RATIO, CONTRACTION RATIO*.

expansion stroke. Same as *POWER STROKE*.

expansion wave. A wave in a supersonic flow field through which the fluid is decreased in density. Cf. *COMPRESSION WAVE, sense 1*.

experimental aircraft. An aircraft built and flown to try out a new or different design, feature, etc. Also *collective*.

experimental mean pitch. Same as *ZERO-THRUST PITCH*.

experimental pitch. The distance a propeller-blade element moves forward in one revolution provided it is delivering no thrust. Sometimes called "effective pitch" (which see, sense 2). Cf. *ZERO-THRUST PITCH*.

explosion turbine. A turbine rotated by gases from an intermittent combustion

process taking place in a constant-volume chamber.

explosive decompression. A very rapid, almost instantaneous, decompression, as may occur, e. g., in the rupture of an aircraft cabin at high altitude.

exposure station. In aerial photography, the point in space at which the film or plate is exposed to make a photograph.

exposure suit. A suit designed to protect a person from a harmful environment, such as freezing water.

extensible flap. A flap that can be extended and rotated downward, increasing both the area and the camber of the wing, used on either the leading or trailing edge. See *FOWLER FLAP*.

exterior ballistics. That branch of ballistics that deals with the motion of projectiles in flight.

external aileron. An aileron, usually an experimental type, mounted clear of an airplane wing, but commonly attached to the wing in some fashion. An interplane aileron is a type of external aileron.

external-airfoil flap. An auxiliary airfoil, usually located below and near the trailing edge of a wing, that is deflected to increase lift and drag.

external-combustion engine. An engine having its working substance derived or created from the combustion of fuel outside of the engine proper. The steam engine is the common example of this type of engine.

external stores. That which is carried externally on an aircraft, such as fuel tanks, bombs, or rockets.

external supercharger. A supercharger external to the engine, i. e., not built into the engine. Cf. *INTERNAL SUPERCHARGER*.

eyelid, noun. Either of two movable parts at the exhaust nozzle of a jet engine, suggestive of an eyelid in appearance and action, which are moved to vary the exhaust opening. Also called a "clamshell shutter."

F

face, noun. Specif., a *BLADE FACE*.

face curtain. A sheet of heavy fabric, installed above an injection seat, pulled down to trigger the ejection seat and

to protect the face, oxygen mask, etc. against wind blast.

factor of safety. The ratio of an ultimate load to some applied load, usually

the probable maximum applied load. See **ULTIMATE LOAD**, sense 1.
fair, *verb tr.* Sometimes, to fair in. To fit into, or to shape, so as to make smooth and streamlined, doing away with abrupt angles or bends, as, to fair a nacelle into a wing.

—faired, *adj.*

fairing, *noun*. 1. A piece, part, or structure having a smooth, streamlined outline, used to cover a nonstreamlined object or to smooth a junction. See note and see **FILLET**. 2. The action of fitting or shaping so as to make smooth or streamlined. See **FAIR**.

In sense 1, although "fairing" is inflected in the plural in the usual way ("fairings"), it is sometimes used as a collective construed as a singular noun, as in "All necessary fairing was installed."

fairlead, *noun*. [Last syllable pronounced "lead."] A tube or a trough-shaped piece, through or over which a cable or rod is passed to guide or support it and to prevent whipping, chafing against another part, etc.

falling leaf. An aerobatic stunt or performance in which an airplane, maintaining the longitudinal axis on an approximately constant heading, makes a series of checked spins, oscillating from side to side and gradually sinking, simulating the movements of a falling leaf.

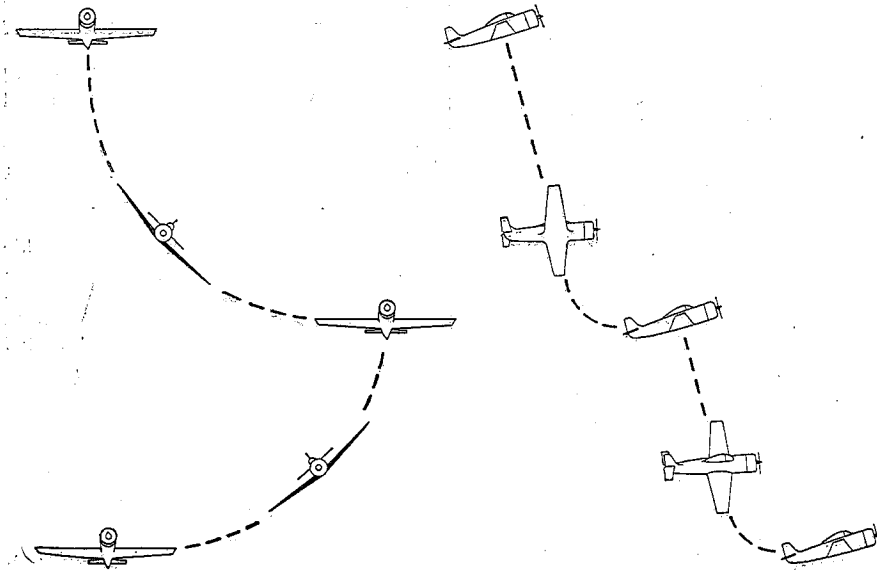

Falling leaf, front and side views.

false rib. A partial-chord airfoil rib, often skeletonized, inserted ahead of the front spar of an airfoil between the main ribs to assist in maintaining the form of the leading edge. Also called a "former rib" or "nose rib."

false spar. A lateral member in an airfoil used only to provide a place of attachment or support for something, as for an aileron or strut.

family, *noun*. A group of objects or phenomena related in some way, as by association, by a common origin, by a common characteristic, etc.

For example, a group of airfoils having the same geometric section but different planforms is sometimes considered a family; likewise for a group of shock waves of equal strength or a group formed over the same surface; etc.

fan, *noun*. 1. a. Any vaned rotary device for producing a current or stream of air and used, e. g., to move the air or gas in a wind tunnel, to cool an engine, to inflate a ballonnet, etc. b. Specif., a multivaned wheel or rotor used to take in air in a bypass engine or ducted-fan engine. It may be either a mere blower or a low-pressure compressor. See **DUCTED FAN**. 2. A propeller, esp. when the emphasis is upon its function of moving air rather than propelling.

fan-cooled, *adj.* Air-cooled with the aid of a fan, as an engine.

fan engine. 1. An internal-combustion reciprocating engine with its cylinders so disposed that they suggest the spread feathers of a hand-held fan. 2. A ducted-fan engine. See **DUCTED FAN**, sense 2.

fan marker. A location marker that transmits a fan-shaped radiation pattern in a vertical direction. See **LOCATION MARKER**.

Fan markers used in an instrument landing system indicate distances to the runway. See **MIDDLE MARKER**, **OUTER MARKER**.

fatigue, *noun*. A weakening or deterioration of metal or other material, or of a member, occurring under load, esp. under repeated or cyclic loading.

Self-explanatory compounds include: fatigue crack, fatigue failure, fatigue load, fatigue resistance, fatigue test.

favorable pressure gradient. A pressure gradient in a fluid flow system or field of decreasing static pressure in the direction of the flow. Cf. **ADVERSE PRESSURE GRADIENT**.

favorable yaw. Yaw in the same direction as the roll of an aircraft, e. g., a yaw to the right with the aircraft rolling to the right. Cf. **ADVERSE YAW**.

feather, *verb tr.* 1. To rotate each blade of a propeller about its root-to-tip axis so that the blade chords are approximately parallel to the thrust axis or direction of airflow. 2. With rotary-wing aircraft, to cause the angle of a blade of the rotor to change periodically.

The following examples show the typical objects of the verb: to feather a blade or blades (of a propeller or rotor); to feather a propeller or rotor.

3. *intr.* Of a rotor blade: To change in blade angle.

feathering, *noun*. The act or process of the verb feather.—*adj.* That feathers.

Used attributively in compounds, including: feathering button, a button that activates a motor to feather a propeller; feathering cam, a cam that feathers rotor blades; feathering motion, the motion of a rotor blade periodically changing its angle; feathering propeller, a propeller that can be feathered; feathering pump, a hydraulic pump for feathering a propeller.

feedback, *noun*. In aeronautics, the transmittal of forces initiated by aerodynamic action on control surfaces or rotor blades to the cockpit controls; the forces so transmitted.

feeder airline. A secondary airline tributary to a main airline and also pro-

viding local flights or commuter service.

Hence, feeder-liner, *noun*, an airliner used on a feeder airline; feeder route, feeder service, etc.

feel, *noun*. The sensation or impression that a pilot has or receives as to his, or his aircraft's, attitude, orientation, speed, direction of movement or acceleration, or proximity to nearby objects, or, as most often used, as to the aircraft's stability and responsiveness to control. See **CONTROL FEEL**.

feeler aileron. A small auxiliary aileron used in conjunction with some aileron systems, such as power-operated, spoiler, or balanced ailerons, principally to produce a control-stick force or "feel" apparent to the pilot. Also called a "guide aileron."

fence, *noun*. A stationary plate or vane projecting from the upper surface of a wing (sometimes continued around the leading edge), substantially parallel to the airstream, used to prevent spanwise flow. Sometimes called a "stall fence."

ferry, *verb tr.* To fly (an aircraft) to a place and there to make delivery of it.

FIDO—Abbreviation for fog, intense, dispersal of—pronounced as a word and used to signify the act or method of dispersing fog over a runway by burning gasoline or other liquid fuel, usually in perforated pipes, at the sides of the runway.

field, *noun*. 1. An AIRFIELD or a LANDING FIELD. 2. A cleared area on the ground, as, he chose a field for a forced landing. 3. A region of some particular activity, as, a field of flow.

fighter, *noun*. A fast, maneuverable airplane, commonly single-place or two-place, designed primarily for attacking and fighting other aircraft in the air.

—fighter aircraft, another term for "fighter," or a term employed as a collective, as, twenty fighter aircraft.

—fighter airplane, or fighter plane, terms used esp. for euphony or for clarity when context so demands.

figure eight. An EIGHT—usually applied only to an ordinary horizontal eight, not applied to an eight on or around pylons, a lazy eight, etc.

figure of merit. A figure representing the strength or value of something: specif., a nondimensional parameter that represents the efficiency with which a rotor produces thrust in hovering.

filament, *noun*. Specif., a VORTEX FILAMENT.

filet, *noun*. Variant of "fillet." Rare.

fillet, *noun*. A concave fairing used to smooth an interior angle, as at a wing-fuselage juncture.

—**filleted**, *adj.* Fitted out with a fillet or fillets.

—**filleting**, *noun*. Fillets collectively; the act of providing with fillets.

film cooling. The cooling of a body or surface, such as the inner surface of a rocket combustion chamber, by maintaining a thin fluid layer over the affected area. Cf. TRANSPIRATION COOLING.

fin, *noun*. 1. A fixed or adjustable airfoil or vane attached longitudinally to an aircraft, rocket, or similar body to provide a stabilizing effect; specif., the vertical fin on an airplane, as disting. from its horizontal counterpart. Cf. STABILIZER and note, and see HORIZONTAL FIN, VANE, sense lb, and VERTICAL FIN. 2. A projecting flat plate or structure. See COOLING FIN.

final, *noun*. Short for FINAL APPROACH.

final approach. That portion or leg of an approach pattern after the last turn, in which the aircraft is in line with the runway in the landing direction and descending. See APPROACH, APPROACH PATTERN.

final mass. The mass of a rocket after its propellants are consumed.

fineness ratio. The ratio of the length of a body to its maximum diameter, or, sometimes, to some equivalent dimension—said esp. of a body such as an airship hull or rocket. See LENGTH-BEAM RATIO.

finger patch. A type of patch having radiating fingerlike projections, sometimes used to attach a line or cable to a gasbag and distribute the load.

fin-stabilized, *adj.* Of a projectile: Stabilized in flight by fins, as in *fin-stabilized* rocket. Cf. SPIN-STABILIZED.

fire balloon. A hot-air balloon that carries a fire beneath the open mouth of the bag to keep the air within heated for prolonged flight. Cf. HOT-AIR BALLOON, MONTGOLFIER.

fire jump. An act or instance of parachuting to the scene of a forest fire. See SMOKE JUMPER.

fire point. The temperature at which a substance, as lubricating oil, will give off a vapor that will burn continuously after ignition. Cf. FLASH POINT.

fire wall. Also *firewall*, *noun*. A fire-proof or fire-resistant wall or bulkhead separating an engine from the rest of an aircraft structure to prevent the spread of any fire originating at the engine.

first officer. In commercial aviation, the officer on an aircraft second in command to the pilot, serving as copilot and corresponding to first mate on a vessel.

first pilot. The pilot who flies, or has responsibility for flying, an aircraft—disting. esp. from the copilot; a pilot qualified to serve in such capacity on a specified type aircraft.

fir-tree root. A tapering compressor-blade root or turbine-blade root having notches in each side, thus resembling a stylized fir tree. See BLADE ROOT, sense b.

fishtail, *noun*. An act or instance of fishtailing.

fishtail, *verb tr.* To swing the tail of (an airplane) from side to side, esp. to reduce speed in landing.—*intr.* To perform this action.

fitting, *noun*. Specif., any small structural part, usually of metal, for joining different structural members.

fix, *noun. In air navigation, the position of an aircraft as determined by visual reference to the surface of the earth, by celestial observations, or by electronic aids, without reference to any former position; also, a place or position the location of which is known, as, to reach a *fix*. See CELESTIAL FIX, RUNNING FIX.*

fixed-area exhaust nozzle. On a jet engine, an exhaust nozzle exit opening which remains constant in area. Cf. VARIABLE-AREA EXHAUST NOZZLE.

fixed-base operation. A business operation carried on at an airport or airfield involving selling and servicing private aircraft, giving flying instruction, making charter flights, etc.

—**fixed-base operator**.

fixed landing gear. A landing gear that remains fixed in position at all times. Sometimes called a "nonretractable landing gear."

fixed-pitch propeller. A propeller whose blade angle cannot be changed.

fixed power-plant weight. The weight of the power plant of an aircraft, its

accessories, and certain associated parts or equipment.

The definition of this term rests upon that of "power plant" (which see, and note), and is therefore subject to special definition in context. In general, however, in addition to engine and accessory weight, the fixed power-plant weight includes, where applicable, the weight of the propeller or propellers, the exhaust, ignition, fuel, and oil systems (including tanks without their contents), and radiator and coolant. The weight of engine instruments is not included.

fixed slot. A slot that remains open at all times—disting. from an adjustable or an AUTOMATIC SLOT.

fixed stabilizer. A stabilizer whose angle of incidence cannot be adjusted.

This term is used only to distinguish such a stabilizer from an adjustable stabilizer. Where a stabilizer is being distinguished from an elevator or other "movable" surface, the stabilizer, whether adjustable or not, is relatively "fixed," and is classed as a "fixed surface." Cf. FIXED SURFACE, FIXED WING. Also see CONTROLLABLE, note.

fixed surface. A stabilizer, fin, or wing either fixed in position during flight or adjustable, but disting. from a movable surface or rotary wing. Cf. FIXED STABILIZER, note, MOVABLE SURFACE.

fixed wing. A wing, which may be foldable or adjustable, that is fixed to the airplane fuselage and outspread in flight, i. e., a nonrotating wing.

—**fixed wing**, *adj.*, as in *fixed-wing* aircraft, *fixed-wing* airplane, *fixed-wing* transport, etc.

flame float. A pyrotechnic device that floats and burns upon the water, used for marking or signaling.

flame front. The boundary or surface of a burning zone progressing through a combustible mixture.

flame holder, or **flameholder**, *noun*. A grid, ring, plate, or other device that provides a sheltered zone for flame stabilization in a moving stream of combustible mixture, as in an afterburner.

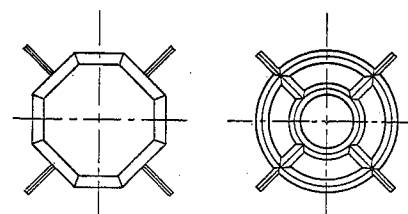

Two types of flame holders.

flameout, *noun*. An act or instance of flaming out. See BLOWOUT.

484035-59-6

flame out, *verb intr.* To *flame out*. Of a jet engine or gas-turbine engine: To cease burning in the combustion section from cause other than deliberate shut-off.

flame tube. In a gas-turbine engine, a tube in which fuel is burned, either inserted as an inner liner in a combustion chamber or mounted in an annulus with others in a common shroud. The flame tube is specially designed for proper mixing of the fuel and air.

flap, *noun*. 1. Specif., a hinged, pivoted, or sliding airfoil or plate, or a combination of such objects regarded as a single surface, normally located at the rear of a wing, extended or deflected for increasing lift or drag, esp. at take-off or during landing. See note. 2. In general usage, any airfoil, plate, shutter, strip, slot, or other more or less flat object or piece, hinged or fastened at one side and capable of being deflected, as: a. A DIVE FLAP. b. A shutter, as in an engine cowling, i. e., a COWL FLAP. c. An aileron, elevator, or similar control surface. See CONTROL SURFACE. d. A SERVO FLAP. e. A HYDROFLAP. f. Any one of the inlet shutters in a certain type of pulsejet engine. 3. A JET FLAP. 4. The movement or deflection of a flap (esp. in sense 1), as, the degree of *flap*. 5. The action of flapping, i. e., of swinging or rotating back and forth or up and down, of oscillating.

In sense 1, see ALFARO FLAP, EXTENSIBLE FLAP, EXTERNAL-AIRFOIL FLAP, LEADING-EDGE FLAP, PLAIN FLAP, SLOTTED FLAP, SPLIT FLAP, TRAILING-EDGE FLAP, ZAP FLAP.

flap, *verb intr.* Of a rotor blade: To move upward and downward while rotating.

—**flapping**, *noun*.

flap aileron. An aileron in the form of a flap, i. e., hinged along or near one edge—disting. esp. from a retractable aileron of the plug type. See FLAP, *noun*, sense 2c.

flap angle. The angular displacement of a flap from its neutral position. The angle is positive when the trailing edge of the flap is below its neutral position.

flaperon, *noun*. [*Flap*+*aileron*.] A control surface used both as a flap and as an aileron. See AILERON DROOP.

flapping angle. In a rotary-wing system, the instantaneous angle between the span axis of a rotor blade and a plane

- perpendicular to the axis of rotation, or, sometimes, a plane perpendicular to some other chosen reference axis.
- flapping hinge.** The hinge about which an articulated rotor blade flaps. See ARTICULATED ROTOR (illus.).
- flap-position indicator.** A flight instrument that indicates the amount of flap deflection.
- flap-type aileron.** Same as FLAP AILERON.
- flare, noun.** 1. A pyrotechnic device that burns with a bright light, such as that dropped by parachute or shot from a gun for illumination or signaling, used as a ground light or marker, etc. See LANDING FLARE, sense 1, SIGNAL FLARE. 2. An outward curve or a spreading out, or something that is so curved or spread, like the side of a bell, as: a. A flight path curved asymptotically in the vertical plane. b. The curve of a bell-shaped nozzle. c. A CHINE FLARE.
- flare, verb intr.** Usually, to flare out. To descend in a smooth curve in landing, making a transition from a steep descent to a direction of flight substantially parallel to the surface.
- flare-out, noun.** An act or instance of flaring out. See FLARE, verb.
- flashback, noun.** A reversal of flame in a system, counter to the usual flow of the combustible mixture.
- flashing beacon.** A beacon that shines forth intermittently, esp. such a beacon with which the duration of light is less than that of darkness. Cf. OCCULTING LIGHT.
- This term is not properly applied to a rotating beacon.
- flash point.** The temperature at which a substance, as fuel oil, will give off a vapor that will flash or burn momentarily when ignited. Cf. FIRE POINT.
- flat-hat, verb intr.** To fly recklessly near the ground; to fly in a witless fashion, playing to the galleries. *Slang.*
- flat spin.** A spin in which the airplane remains in a more level attitude than that of a normal spin, with centrifugal force holding the airplane away from the axis of the spin.
- fattop, noun.** AN AIRCRAFT CARRIER (in sense 2). *Colloq.*
- F layer.** A term applied to a layer of concentrated ionization in the ionosphere that exists in the region between altitudes of about 90 and about 300

- miles, existing in the daytime as two separate layers, the F₁ and F₂ layers.
- Flettner tab.** [After Anton Flettner (1885-), German engineer.] A SERVO TAB.
- flexibility, noun.** Specif., the capability of an engine to run smoothly and to give the required performance at varying rotational speeds and under varying operating conditions.
- flicker control.** Radio control of an aircraft, missile, etc. in which the control surfaces are deflected to their fullest degree with any motion of the remote control. Cf. PROPORTIONAL CONTROL and see BANG-BANG CONTROL.
- flier, noun.** 1. An aircrew member, esp. a pilot. 2. An aircraft. *Obs.*
- flight, noun.** 1. a. The movement or motion of an aircraft or other flying vehicle, or of a projectile through air, or through the region above or beyond the earth, as, a plane in steady flight; an act or instance of moving through air or space, as, a good flight. b. Also of persons so moving in an aircraft or other flying vehicle, as, a pilot ready for flight. 2. An excursion, trip, or mission by air or through space, as, a flight from New York to Chicago; a regularly scheduled trip by air, as, the addition of new flights by an airline. 3. An aircraft making a trip, mission, etc., as, a flight that is low on fuel. 4. The act of operating or functioning in flight (the word here used in sense 1)—said of a component, as, rotor-blade failure after 250 hours of flight. 5. a. A military or semimilitary aviation organization, variously defined; an Air Force organization, subordinate to, or part of, a squadron. b. An aircraft formation, number and pattern varying with circumstance or context, as, a flight of fighter planes. 6. The ability of man to fly, or the phenomenon of flying, as, the changes brought about by flight.
- flight attitude.** The attitude (which see) of an aircraft, rocket, etc. in flight; technically, the attitude of an aircraft with respect to the relative wind.
- flight characteristic.** A characteristic exhibited by an aircraft, rocket missile, or the like in flight, such as a tendency to stall or to yaw, an ability to remain stable at certain speeds, etc. See CHARACTERISTIC and note.

- flight check.** 1. A flight made to check an aircraft or the accuracy or coverage of its equipment or instrumentation. 2. A proficiency check in flight of a pilot or other aircrew members. Also, a CHECK FLIGHT.
- flight-check, verb tr.
- flight control.** 1. *In plural.* Controls for guiding or trimming an aircraft, missile, or the like in flight, such as cockpit controls, control surfaces, pressure controls on an airship, etc. 2. A general if somewhat loose term applied to any activity or organization that directs and controls the movement of aircraft. See AIR TRAFFIC CONTROL.
- flight control surface.** Same as CONTROL SURFACE.
- flight crew.** Same as AIRCREW.
- flight deck.** 1. On certain large airplanes, an elevated deck or level occupied by the pilot and copilot and sometimes other members of the crew. 2. On an aircraft carrier, the deck on which aircraft take off and land.
- flight engineer.** An aircrew member on certain large aircraft who supervises and is responsible for the mechanical operation of the ship in general, including the operation of the power plant and of the other mechanical and electrical aircraft systems, such as the heating system, cooling system, control system, etc. The duties of the flight engineer commonly include supervising preflight checks, adjusting power settings in flight, and performing or supervising in-flight maintenance.
- flight envelope.** The boundary depicting the limits of altitude and speed which a given aircraft cannot safely exceed. Loosely, the flight regime within this boundary.
- flight indicator.** A general term applied to a flight instrument that indicates attitude, such as an artificial horizon, an attitude gyro, a kind of cathode-ray attitude indicator, etc.
- flight instructor.** A person who instructs in the art of piloting aircraft; specif., a pilot qualified to teach flying and who possesses a valid instructor's rating.
- flight instrument.** An aircraft instrument used in the control of the direction of flight, attitude, altitude, or speed of an aircraft. Flight instruments include the artificial horizon,

- airspeed indicator, altimeter, compass, rate-of-climb indicator, flap-position indicator, accelerometer, turn-and-bank indicator, automatic pilot, etc. Sometimes called a "flying instrument." See INSTRUMENT.
- Certain flight instruments that are also used in navigation, such as the airspeed indicator or the altimeter, are sometimes classed as navigation instruments.
- flight line.** 1. The general area surrounding the hangars at an airdrome, including aprons and ramps, where aircraft are made ready or kept ready for flight; a line of parked aircraft, ready for flight. 2. Same as LINE OF FLIGHT.
- flight log.** 1. A log in which the information concerning a particular flight is entered, such as information on miles flown, altitudes of flight, airspeed, temperature, wind, etc. 2. An airborne device that automatically records on a screen or map the line or course flown by an aircraft.
- flight Mach number.** A Mach number attained in flight, as disting. from one attained in a wind tunnel.
- flight mechanic.** A mechanic in an aircrew.
- flight operator.** A person who flies a pilotless aircraft or drone by remote control.
- flight path.** The path made or followed in the air or in space by an aircraft, rocket, etc., i. e., the continuous series of positions occupied by a flying body; more strictly, the path of the center of gravity of the flying body, referred to the earth or other fixed reference. See GLIDE PATH.
- flight-path angle.** The angle between the flight path of an aircraft or other flying body and the horizontal. This angle is positive when the aircraft or body is climbing.
- flight pattern.** Any pattern flown by an aircraft, such as an approach pattern or traffic pattern.
- flight plan.** A detailed outline or statement, written or oral, relative to a given flight, submitted to Air Traffic Control prior to take-off. The flight plan contains information such as the pilot's name, type of aircraft, point of departure and destination, intended cruising altitude and true airspeed, etc.
- flight profile.** A graphic portrayal or plot of an aircraft's flight path in the vertical plane.

flight recorder. A general term applied to any instrument or device that records information about the performance of an aircraft in flight, or about conditions encountered in flight, for future study and evaluation. Flight recorders may make records of airspeed, outside air temperature, vertical acceleration, engine rpm, manifold pressure, or any other pertinent variable for a given flight.

flight refueling. Same as AIR REFUELING.

flight simulator. 1. Specif., a training device or apparatus that simulates certain conditions of actual flight or of flight operations, such as piloting, bombing, gunnery, etc. 2. More generally, anything that simulates some condition of actual flight, such as an altitude chamber.

flight strip. 1. A cleared strip of land for the take-off and landing of airplanes, often used as an auxiliary or emergency landing field; an AIRSTRIP. 2. *Aerial Photography.* A consecutive series of aerial photographs taken along a single line of flight.

flight surgeon. A military or naval medical officer specializing in aviation medicine, and so designated by proper authority.

flight test. A test of an aircraft, of a rocket, etc., of an aircraft or rocket engine or other component, of a system, or of a person, in or by actual flight.

—flight-test, *verb tr.*

flight time. 1. Time spent in flight or in flying operations, measured, when exactness is required, between specified instances, as between the commencement of the take-off run and the end of the landing run. Also called "flying time." 2. The time at which a flight begins.

flight training. Training and instruction in flying or flying duties and related subjects—applied esp. to pilot training, but also applied to navigation training, flight-engineer training, aerial-gunnery training, etc. Also called "flying training."

flipper, noun. A plate, surface, or the like that swings, or is made to swing, back and forth or up and down; specif., an elevator. *Slang.*

float, noun. Specif., a buoyant structure, usually boat-shaped and decked over,

fitted to an aircraft to support or stabilize it on water and to allow it to take off and alight on water. Sometimes called a "pontoon." See STABILIZING FLOAT.

Twin floats or a single float may be fitted to an airplane in place of main landing wheels; with a single main float, outboard floats are necessary. On a helicopter, floats may consist of inflated bags.

float, verb intr. 1. Of a balloon or airship: To remain suspended, or to ride, in the air by virtue of its aerostatic gas. 2. Of an airplane: To sail or glide along of its own accord near the ground, esp. when the pilot is attempting to touch down, owing to the ground effect. See BALLOON, *verb*, sense 1. 3. Of a control surface: To ride freely in the airstream.

float displacement. The volume or weight of the water displaced by a float.

floating aileron. An aileron that is free to seek its own angle of attack in flight as determined by the hinge moments produced by the air forces, except when displaced by the pilot.

floatplane, noun, or float seaplane. An airplane fitted out with a float or floats in place of the main landing wheels—disting. from a FLYING BOAT. See FLOAT, *noun*, note, SINGLE-FLOAT SEAPLANE, and cf. SEAPLANE.

floatation gear. 1. Gear or apparatus, commonly inflatable bags, vests, and the like, carried aboard an aircraft to support the aircraft or persons downed in water. 2. A float-type landing gear.

flow, noun. A stream or movement of air or other fluid, or the rate of fluid movement, in the open or in a duct, pipe, or passage; specif., an AIRFLOW.

See CHOKED FLOW, CIRCULATORY FLOW, COMPRESSIBLE FLOW, FREE MOLECULAR FLOW, HYPERSONIC FLOW, INCOMPRESSIBLE FLOW, INDUCED FLOW, INFLOW, IRRATIONAL FLOW, LAMINAR FLOW, MIXED FLOW, ONE-DIMENSIONAL FLOW, POTENTIAL FLOW, ROTATIONAL FLOW, SEPARATED FLOW, SLIP FLOW, STEADY FLOW, STREAMLINE FLOW, SUBSONIC FLOW, SUPERSONIC FLOW, TRANSONIC FLOW, TURBULENT FLOW, TWO-DIMENSIONAL FLOW, UNIFORM FLOW, UNSTEADY FLOW. In addition to these flows, other flows are sometimes distinguished as occasion demands, such as forced flow, parallel flow, etc. Such terms as these are usually self-explanatory. See CROSS FLOW.

flow coefficient. A coefficient expressing the ratio of an actual flow to a reference flow.

flowmeter, noun. An instrument for measuring a rate of flow, as in pounds or gallons per unit of time. See FUEL FLOWMETER.

flow separation. The breakaway of flow from a surface; the condition of a flow separated from the surface of a body and no longer following its contours. See LAMINAR SEPARATION.

fluid, noun. Any liquid, gas, or mixture thereof.

fluid flow. The stream or movement of a fluid, or the rate of its movement.

flutter, noun. A vibration or oscillation of definite period set up in an aileron, wing, or the like by aerodynamic forces and maintained by the aerodynamic forces and by the elastic and inertial forces of the object itself. See STALL FLUTTER, TORSIONAL FLUTTER, and cf. BUFFETING.

—single-degree-of-freedom flutter, binary flutter, ternary flutter. Flutter in one, two, or three degrees of freedom, respectively.

flutter speed. The airspeed at which flutter sets in.

flutter-speed coefficient. A coefficient expressing the ratio of flutter speed to the product of the semichord of an airfoil and one of its natural structural frequencies.

flux gate. A direction-sensing element utilizing three coil-wound legs, used in remote-indicating compass systems, such as the gyro flux-gate compass.

flux gate compass. Same as GYRO FLUX GATE COMPASS.

flux valve. Same as FLUX GATE.

fly, verb. I. *tr.* 1. To operate or guide (an aircraft, rocket, etc.) so as to move through air or space, either by direct control of the vehicle from within or by remote control; to launch or fire into and through the air or space, as, to fly a sounding rocket from a ground station. 2. To guide or direct an aircraft on, along, or over, as, to fly a heading, to fly a course, or, to fly the ocean. 3. To conduct, serve on, or ride in an aircraft or other flying vehicle during the performance of, as, to fly a mission. 4. To carry or transport in an aircraft or other flying vehicle, as, to fly mail. 5. To operate in flight, or to operate so as to achieve a desired manner of flight, as, to fly a servo tab. II. *intr.* 1. To move through, or remain suspended in, the air or space in and by means of an aircraft or other

vehicle, as either a pilot, crew member, or passenger, as, to fly from New York to London. 2. Of an aircraft, rocket, or the like: To move through air or space; also said of a component of an aircraft or other flying vehicle, as, a rotor that flies at a forward speed of 120 miles per hour, or, a jet engine now flying in U. S. aircraft.

III. *In special uses:* 1. To fly by (or on) instruments, or to fly instruments. To fly along using instruments to determine altitude, attitude, etc., without visual reference to the ground or sky; to fly blind. See BLIND, *adj.* and *adv.* 2. To fly by the seat of one's pants. To fly relying on the sense of feel. *Slang.* See FEEL. 3. To fly contact. To navigate by visual reference to the ground. See CONTACT, *adj.* and *adv.* 4. To fly cross country. See CROSS COUNTRY. 5. To fly a flight plan. To follow a flight plan in making a flight.

fly-by, noun. An act or instance of flying by or over a given place on the surface; a performance, demonstration, or salute in which aircraft fly past or over, usually at a comparatively low altitude.

flier, noun. Variant of "flier" (in sense 1 or sense 2).

flying, noun. 1. Movement through the air; the act of piloting aircraft, or of moving through the air or traveling in aircraft. 2. The art, skill, or practice of piloting aircraft, as, to learn flying.

flying automobile. An automobile capable by ready conversion of flying as an airplane.

Whether a vehicle such as this is termed a "flying automobile" or a "roadable airplane" depends both on the design and appearance of the vehicle and on how one regards it, i. e., on whether the vehicle is designed or regarded principally as an automobile or as an airplane. In general, an automotive vehicle with detachable wings is termed a "flying automobile." See CONVERTIBLE and cf. ROADABLE AIRPLANE and note.

flying barrel. A coleopter. *Slang.*

flying boat. A type of airplane or seaplane having a boatlike main central body or hull, allowing the plane to float, take off, and alight on water. Cf. SEAPLANE.

flying-boat hull. A more particular term for "seaplane hull" (which see).

flying bomb. A self-propelled bomb, usually an explosive-laden pilotless airplane, such as the German V-1 of WW II.

flying boom. A tube equipped with aerodynamic controls near its tip by means of which it is guided through the air from a tanker aircraft to a receiver aircraft in air refueling.

flying circus. 1. A performance of acrobatics by or with aircraft; a company that performs acrobatics or acrobatics with aircraft. See AEROBATICS and AEROBATICS. 2. A military organization of fighter planes—applied particularly to certain German fighter squadrons of WW I, such as that of Baron von Richthofen.

flying field. An airfield or air base—sometimes applied particularly to a small airfield for privately owned planes, or to a more or less temporarily established military airfield.

flying hour. An hour spent in flying or flying operations by a person, by an aircraft, or by an aircraft engine or other component.

The method of reckoning flying hours varies, and is subject to special regulation.

flying instrument. Same as FLIGHT INSTRUMENT.

flying laboratory. An aircraft specially equipped and instrumented to carry out experiments or tests while airborne, such as aerodynamic experiments, tests of icing systems, etc.

flying machine. A powered aircraft or a glider; specif., a powered heavier-than-air-aircraft.

In its broad sense, this term is applied to any man-carrying aircraft except the balloon; but cf. MACHINE and note.

While considered by some to be an obsolete term, "flying machine" is rather only somewhat archaic, never having fallen entirely into disuse.

flying quality. Any quality or characteristic (which see, and note) of the stability and control of an aircraft, governing its safety and ease in flight.

flying speed. The speed at which an aircraft flies; the speed which an aircraft must have to provide sufficient aerodynamic lift in order to become, or to remain, airborne.

flying suit. A pair of coveralls, a fleeced-lined suit, an electrically heated suit, or the like designed for flying—a general term, but not usually applied to a special suit such as a g-suit.

flying tab. Same as SERVO TAB.

flying test bed. An aircraft, rocket, or other flying vehicle used to test other objects in flight.

flying time. Same as FLIGHT TIME (in sense 1).

flying training. Same as FLIGHT TRAINING.

flying trim. Specif., the trim of an aircraft in flight, i. e., its trim with respect to the balance between static and dynamic moments.

flying vehicle. A vehicle designed to fly through air or space. See VEHICLE and note.

flying wing. A type of airplane consisting essentially of a wing, the fuselage being an integral part of the wing and no empennage being present, the control surfaces or devices being attached to the wing itself. Sometimes called a "tailless airplane" (which see).

flying wire. A wire or cable that braces a wing against lift forces or other forces acting in the same direction. Also called a "lift wire." Cf. LANDING WIRE.

folding blade. A rotor blade which, together with the other blades in the rotor, can be turned or swung back in one way or another when not in use; esp., a blade that pivots back so as to lie with the other blades in the rotor substantially along the center line of the rotorcraft.

folding fin. A fin hinged at its base to lie flat, esp. a fin on a rocket missile that lies flat until the missile is in flight.

folding wing. An airplane wing hinged or pivoted so that it may be turned back against, or over, the airplane fuselage, used esp. on carrier planes.

foot-to-head acceleration. *Av. med.* 1. Accelerating force acting on the body in the direction from the foot to the head; acceleration in the direction that this force is applied; also, SEAT-TO-HEAD ACCELERATION. 2. An inertial force acting in the direction from the foot to the head. *Rare.* See ACCELERATION, sense 3 and final note.

force, verb tr. *To be forced down.* To be compelled to make a forced landing or ditching, as, *forced down* by enemy aircraft, or, *forced down* by engine failure.

forced landing. A landing or crash landing necessitated by some adverse circumstance, such as mechanical failure of the aircraft, bad weather, lack of fuel, etc. See DITCHING.

fore, adj. Front, forward, as in *fore planing surface*.—*adv.* Toward the

front; forward—used only in the phrase *fore and aft*, as, an envelope tapered *fore and aft*.

fore-and-aft, adj. Along the length; longitudinal, as in *fore-and-aft attitude*, *fore-and-aft stability*.

forebody, noun. 1. The front or forward part of a body; a body in front of another. 2. Specif., the part of a seaplane float or hull forward of the main step; more restrictively, the bottom surface of a float or hull forward of the step.

forefoot, noun. The forward point on a boat, hull, or float where the bow or stem meets the keel.

formation, noun. An arrangement or grouping of two or more flying aircraft in a particular pattern.

Compounds include *formation flight*, *formation flying*.

formation light. A light, usually mounted atop the fuselage of an airplane, used esp. to aid in holding formation during darkness or conditions of poor visibility.

form drag. That part of the drag acting upon a body that is ascribed to its form. Inasmuch as pressure drag is a function of form, form drag and pressure drag are sometimes considered synonymous.

former, noun. A transverse member, sometimes a bulkhead, that gives form to a body such as a fuselage, and that carries the longerons and stringers when such members are used. See FRAME, sense 2.

former rib, or form rib. Same as FALSE RIB.

forward, adj. Specif., at, near, in, or belonging to the front or forepart of a ship, aircraft, etc., as in *forward balloonet*, *forward fuselage*, *forward tank*.

forward slip. The movement of an aircraft in a yawed attitude and following its original forward direction of flight.

This is chiefly a pilot's term and is distinguished from a sideslip (in sense 2a, which see); from the point of view of the aeronautical engineer, the forward slip is a species of sideslip (in sense 1, which see).

four-bank eight. A type of horizontal eight in which the airplane banks four times during the performance, remaining at all other times in straight and level flight, the resulting flight path resembling an eight with its top and

bottom flattened. This type of eight is sometimes centered on a crossroads, with the "X" of the figure bisecting the angles between the roads. See EIGHT.

four-course radio range. A radio range that transmits four radio beams or courses for the guidance of aircraft. See ADCOCK RADIO RANGE, LOOP-TYPE RADIO RANGE.

four-cycle engine. A FOUR-STROKE-CYCLE ENGINE.

four-engine, or, less often, four-engined, adj. Of aircraft: Having four engines, esp. four reciprocating engines. See ENGINE, note, TWIN-ENGINE, and cf. FOUR-JET.

four-jet, adj. Having four jet engines, as in *four-jet bomber*.

four-motor, or four-motored, adj. Having four motors. *Rare.* See FOUR-ENGINE.

four-stroke-cycle engine. An engine that requires four strokes of the piston to complete a cycle of operations within the cylinder, the four strokes being the suction, or intake, stroke for the combustible mixture, the compression stroke, the power stroke, and the exhaust stroke.

Fowler flap. [After Harlan D. Fowler (1895-), American aeronautical engineer.] A type of extensible trailing-edge flap that increases both the camber and wing area. See EXTENSIBLE FLAP.

frame, noun. 1. An AIRFRAME. 2. An open or skeleton former (which see). 3. The skeleton structure of something, as, the metal *frame* of a stabilizer.

free air. Unconfined or undisturbed air, or air outside of some region under consideration, as: a. The air encountered in flight, as disting. from the air in a wind tunnel. b. The air ahead or outside of a region affected by the passage of a body. c. The air outside of a cabin, a duct, a compressed-air tank, etc. d. In meteorology, the air or atmosphere uninfluenced by objects or features on the surface of the earth, as mountains or buildings; air above the range of surface recording instruments.

—*free-air, adj.*, as in *free-air stream*.

free-air temperature. The temperature of the air outside an aircraft and unaffected by the aircraft with respect to temperature.

free-air thermometer. A thermometer that measures free-air temperature.

free balloon. A nondrigible balloon, usually spherical, that floats unmoored through the air.

The ascent and descent of a manned free balloon may be controlled by the use of ballast and gas valves; a skilled pilot, therefore, can exercise a certain degree of directional control by seeking a level where a favorable wind will carry him in the desired direction.

free fall. a. The fall or drop of a body, such as a rocket, not guided, not under thrust, and not retarded by a parachute or other braking device. b. The drop of a parachutist through the air before opening his parachute.

free flight. Unconstrained or unassisted flight, as: a. The flight of a rocket after consumption of its propellant or after motor shut-off. b. The flight of an unguided projectile. c. The flight of a free balloon, or of an airship with its engines not operating. d. Untethered flight, as of a helicopter; the flight of a glider after release of its towline. e. The flight in certain kinds of wind tunnel of an unmounted model.

free-flight angle. The angle between the horizontal and a line in the direction of motion of a flying body, esp. a rocket, at the beginning of free flight.

free-flight tunnel. A tunnel or gallery in which models are tested without being moored or tethered, or which are tested in actual movement; esp., a type of wind tunnel in which dynamic models are sustained by the air in the test section.

free gyroscope. A gyroscope not provided with an erection system, i. e., a gyroscope free to move about its axes.

free jet. A fluid jet without any solid boundaries, such as a jet discharged into the open.

free molecular flow. Flow about a body in which the number of collisions between the molecules of the fluid is negligible compared with the collisions between these molecules and the body.

free-piston engine. A type of engine that delivers all of its power through a shaft driven by a turbine rotated by combustion gases and compressed scavenging air generated between freely sliding pistons working in opposition.

free rocket. A rocket unguided in its flight.

free stream. 1. The stream of fluid outside the region affected by a body in the fluid. 2. The stream above a boundary layer.

—*free-stream, adj.*, as in *free-stream dynamic pressure, free-stream flow, free-stream Mach number, free-stream static pressure, free-stream temperature, free-stream turbulence, free-stream velocity* (see REMOTE VELOCITY), etc.

free-to-trim method. A method of testing a model or aircraft, as in a wind tunnel or in a tank, in which the model or aircraft is left free to rotate about its lateral axis.

free turbine. In a gas-turbine engine, a turbine wheel that drives the output shaft and is not connected to the shaft driving the compressor.

free-type parachute. A parachute manually opened by means of a rip cord. Cf. ATTACHED-TYPE PARACHUTE.

free vortex. A vortex revolving in a fluid and free to be carried along by the fluid, such as a vortex springing from an airfoil tip—sometimes disting. from a BOUND VORTEX.

free-vortex compressor. An axial-flow compressor designed so as to impart to the fluid tangential velocities that are inversely proportional to the distance from the axis of rotation, as in a vortex.

freewheel, noun. Specif., a device that disengages a rotor or propeller from its engine and permits the blades to windmill without rotating the engine, or a device that permits a rotor to turn freely when its speed exceeds that of the engine.

French landing. With an airplane having a tail skid or tail wheel, a landing in which the tail is held off the ground as long as possible before coming to a stop.

friction, noun. The action of one body or substance rubbing against another, such as the air rubbing against the skin of an aircraft; the resistance to motion caused by this rubbing.

frictional drag. Same as FRICTION DRAG.

frictional heating. Heating arising from friction. See AERODYNAMIC HEATING.

friction damper. A device that damps or checks oscillation or movement by frictional resistance, such as a device incorporated in a rotary-wing system to damp oscillation of the blades in the plane of rotation.

friction drag. In aerodynamics, drag arising from tangential forces at the surface of a body moving in a fluid, owing to the viscosity of the fluid. Sometimes called "skin-friction drag" or "viscous drag."

friction horsepower. The horsepower required to overcome the friction of moving parts and fluids within an engine and its accessories. The friction horsepower is the difference between the indicated horsepower and the brake horsepower.

friction layer. *Meteorol.* The lower layer of the earth's atmosphere, approximately 1500 to 3000 feet thick, whose motion is affected by friction with the earth's surface.

friction mean effective pressure. That part of the indicated mean effective pressure that produces the friction horsepower of an engine. See INDICATED MEAN EFFECTIVE PRESSURE.

friction pressure drop. The decrease in the pressure of a fluid flowing through a passage attributable to the friction between the fluid and the passage walls.

Frise aileron. [After Leslie George Frise, (1897-), English engineer.] A type of aileron having its leading edge, or nose portion, projecting ahead of the hinge line, and the lower surface of which is in line with the lower surface of the wing when the aileron is in the neutral position. When the trailing edge of the aileron is raised, its leading edge projects below the lower surface of the wing, increasing drag.

front, noun. *Meteorol.* a. A FRONTAL SURFACE. b. The line of intersection between a frontal surface and the earth's surface.

frontal area. The projection of a body, as a complete aircraft or a nacelle, on a plane perpendicular to the fore-and-aft axis of the body.

frontal surface. *Meteorol.* A surface of discontinuity between two air masses of dissimilar characteristics. Also called a "front."

Froude number. [Pronounced "flood." After William Froude (1810-1879), English engineer.] The nondimensional ratio of the speed of a body in a fluid to the square root of the product of a linear dimension of the body and the acceleration of gravity. In the test of a model on a water surface (e. g., a

model of a seaplane hull), it defines the corresponding speeds at which the wave patterns produced by the model and by the full-size prototype are similar. The Froude number may be written

$$\frac{V}{\sqrt{lg}}$$

where V is the velocity of the fluid, l is a linear dimension, and g is the acceleration of gravity.

fuel, noun. Any substance used to produce heat, either by chemical or nuclear reaction, as used, e. g., in a heat engine.

With a liquid-propellant rocket engine, the fuel is ordinarily distinguished from the oxidant where these are separate.

The word "fuel" is often used in compounds, some self-explanatory examples of which follow: fuel atomizer, fuel booster pump, fuel capacity, fuel-feed system, fuel flow, fuel line, fuel pressure gauge, fuel-quantity gauge, fuel shut-off valve, fuel strainer, fuel system, fuel tank, fuel transfer, fuel vapor.

fuel accumulator. An accumulator (which see) in a fuel system.

fuel-air ratio. The ratio, by weight, of fuel to air in a combustible mixture.

fuel-air-ratio indicator. Same as FUEL-MIXTURE INDICATOR.

fuel cell. A fuel tank, esp. one of a number of fuel tanks, as in an airplane's wing; also, a compartment within a fuel tank.

fuel consumption. The using of fuel by an engine or power plant; the rate of this consumption, measured, e. g., in gallons or pounds per hour. See SPECIFIC FUEL CONSUMPTION.

fuel-cooled, adj. Cooled by fuel. Said of a rocket engine, an oil cooler, etc. See REGENERATIVE COOLING.

fuel dope. An antiknock additive. See DOPE, sense 2.

fuel-evaporation ice. Ice formed in the induction system of an engine owing to the cooling of moisture-laden air by the evaporation of fuel. Sometimes called "fuel ice."

fuel flowmeter. A flowmeter (which see) that measures and indicates the rate of fuel flow to an aircraft's engine or engines, as in pounds per hour. Also called a fuel-flow indicator.

fuel ice. Same as FUEL-EVAPORATION ICE.

fuel injection. The forced introduction or injection of fuel or of a fuel-air mixture into the intake passages of an engine or into the combustion chamber or chambers by means of a pressure differential other than that caused by the induction airflow in the engine.

fuel knock. KNOCK.

fuel metering. The regulating of a fuel flow so as to obtain the proper fuel-air ratio for the desired kind of combustion.

fuel-mixture indicator. An instrument that indicates, by analysis of combustion gases, the fuel-air ratio of the mixture supplied an engine. Also called a "fuel-air-ratio indicator." See EXHAUST-GAS ANALYZER.

fuel reserve. Specif., an amount of fuel carried in excess of that calculated to be sufficient for a given flight.

fuel selector. A control or valve used to select fuel from one tank or another in a system.

fuel-tank vent. A vent for overflow in a fuel tank or for equalization of pressure inside and outside the tank.

full-cantilever, adj. Supported at one end only, as in *full-cantilever* wing, a wing attached to the fuselage at one end and not supported otherwise. Cf. SEMICANTILEVER.

full-feathering propeller. Any propeller that can be feathered. See FEATHERING and note.

full load. The entire load sustained by an aircraft at rest or in a condition of unaccelerated flight; the amount of

this load, equivalent to the gross weight of the aircraft.

full rich. A fuel-air mixture setting providing the maximum amount of fuel flow.

full-scale, adj. Not reduced in size or dimensions, as in *full-scale* model; carried out with full-size aircraft or models, as in *full-scale* flight, *full-scale* test; used for full-size aircraft or models, as in *full-scale* wind tunnel.

fusee, noun. An igniter squib for a rocket.

fuselage, noun. The main or central structure of a heavier-than-air aircraft, typically elongated and approximately streamlined, which carries the crew, passengers, or other load. The word "fuselage" is applied to the main central body or structure (sometimes quite atypical) of a fixed-wing airplane, of a rotary-wing airplane, or of a glider, but it is usually not applied to a flying-boat hull.

fuselage strut. A strut between the longerons of a fuselage.

future position. The position that a moving object or body will occupy at a given instant in the future, calculated from its direction and speed.

G

g, noun. An acceleration equal to the acceleration of gravity, approximately 32.2 feet per second per second at sea level—used as a unit of measurement for bodies undergoing acceleration.

For example, if a pilot is subjected to four *g's* in recovering from a dive, he is undergoing acceleration at the rate of approximately 32.2×4 feet per second per second; if he weighs 200 pounds, his effective weight is 800 pounds. Sometimes called a "g-force."

galley, noun. A kitchen on a vessel or aircraft.

gangway, noun. A passageway in an aircraft, giving access to various positions or places; an aisle.

gantry, noun. Specif., a frame structure mounted on side supports to span a vehicle, usually travelling on rails, used for erecting and servicing large, vertically-launched rockets.

gap, noun. The distance between the chords of two superposed surfaces.

gap-chord ratio. The ratio of the gap between two superposed surfaces to their chord; with surfaces of unequal chord, a mean chord is used.

gap-span ratio. The ratio of the gap between two superposed surfaces to the span; with surfaces of unequal span, either the upper span, lower span, or mean span is used.

gasbag, noun. 1. A bag (which see, sense 2) holding the lifting gas of a balloon or airship; a GAS CELL. 2. Also applied to the complete aerostat. *Popular.*

gas cell. One of the several compartments or chambers in certain airships, usually in a rigid airship, holding aerostatic gas; also, sometimes, applied to the single, entire envelope of a balloon or airship. See GASBAG.

gascolator, noun. A kind of gasoline strainer incorporating a sediment bulb.

gas generator. A device for producing gas, as: a. An apparatus that supplies

gas under pressure to a turbine in the turbopump feed system of a rocket engine. b. An apparatus that produces some kind of gas, such as hydrogen.

This term is sometimes applied to the compressor-burner portion of a gas-turbine engine.

gas turbine. 1. A turbine rotated by expanding gases, as in a turbojet engine or in a turbosupercharger. 2. A GAS-TURBINE ENGINE.

gas-turbine engine. An engine (which see, note) incorporating as its chief element a turbine rotated by expanding gases. It consists essentially in its most usual form of a rotary air compressor with an air intake, one or more combustion chambers, a turbine, and an exhaust outlet. Aircraft engines of this type usually have their power applied mainly either as jet thrust (*turbojet engine*) or as shaft power to rotate a propeller (*turbopropeller engine*). (See entries on these types.) The aircraft gas-turbine engine also has a powerplant application as a source of compressed air, esp. on certain helicopters. (See JET ROTOR.) Gas-turbine engines are sometimes combined, esp. in the turbopropeller type (*double, dual, or twin turboprop*), and the essential principle is used in a compound engine. See COMPOUND ENGINE, FREE-PISTON ENGINE.

Gas-turbine engines are sometimes classified according to: (1) the manner of gas or air flow in or through the engine, as in *axial-flow engine, bypass engine, centrifugal-flow engine, reverse-flow engine*, or (2) the treatment of the working substance, as in *closed-cycle engine, open-cycle engine*. (See individual entries on all these types.) See DUCTED FAN, sense 2, JET ENGINE.

gas volume. The volume of the gas in an aerostat; specif., the maximum volume of gas an aerostat can contain.

GCA—Abbreviation for *ground-controlled approach*.

G class. A class of Goodyear airships having a volume of 196,000 cubic feet.

gear, noun. Specif., short for LANDING GEAR.

gear-driven supercharger. A supercharger driven by gears from the engine—disting. from a TURBOSUPERCHARGER.

geared spring tab. A tab (which see) that combines the features of a balancing tab and a spring tab.

geared tab. Same as BALANCING TAB.

geodetic construction. A kind of construction, as of an airplane wing or fuselage, in which structural members follow diagonal geodetic curves (i. e., diagonal curves along the shortest distance between points on a curved surface), resulting in a "basket-weave" framework.

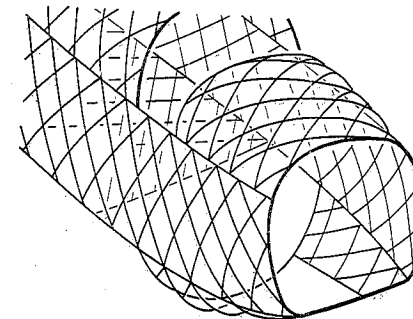

Geodetic construction (fuselage).

geometric angle of attack. The angle of attack between the geometric chord of an airfoil and the flight path or line of movement of the airfoil, or between the geometric chord and the direction of the relative wind if induced effects are not present or are ignored. The geometric angle of attack is usually called simply the "angle of attack," unless it is necessary to distinguish it from other angles of attack under discussion.

geometric chord. A chord established for geometric calculations only. See CHORD, sense 2.

geometric pitch. a. The pitch or blade angle of a propeller or rotor blade measured from the geometric chord. See BLADE ANGLE. b. Technically, with respect to a propeller, the distance the propeller would move forward in one revolution if it moved along a helix having an angle equal to the geometric blade angle, i. e., the distance it would move if it were not for distance loss caused by slip.

geometric twist. The twist of an airfoil having different geometric angles of attack at different spanwise stations. See AERODYNAMIC TWIST and note.

geometric washin. Washin (which see) with respect to geometric angles of attack.

geometric washout. Washout (which see, and note) with respect to geometric angles of attack.

geostrophic wind. A wind resulting from a balance of pressure force (high pressure to low pressure) and Coriolis force, mathematically calculated and considered to blow parallel to straight isobars or contour lines.

get-away, noun. The act of breaking contact with the surface of the earth.

—**get-away speed.** The speed at which an airplane lifts from the surface in the take-off run—said esp. of seaplanes.

g-force, or G-force, noun. An accelerating force. See *g*.

gills, noun. Something likened to the gill slits or flaps of a fish, such as a set of cowl flaps. *Popular.*

giro, noun. A clipped form of the word "autogiro." *Popular.*

gland, noun. Specif., any of various devices permitting pipes, lines, etc. to pass into a container, chamber, or the like without leakage; on a balloon or airship, a device permitting a line to pass through the gasbag or envelope without leakage, or a device in the envelope of an airship permitting connections with pressure lines through the envelope.

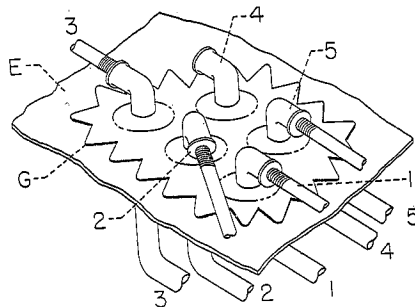

One kind of gland (airship). G gland; E airship envelope. 1, 2 helium pressure lines to manometers; 3 helium sampling line; 4, 5 air pressure lines from ballonets to manometers.

glaze, noun, or glaze ice. A coating of strong, dense, transparent ice, smooth, rippled, or rough, formed in layers, e. g., upon the surface of an aircraft in flight. Sometimes called "clear ice."

glide, noun. 1. A controlled descent by a heavier-than-air aircraft under little or no engine thrust in which forward mo-

tion is maintained by gravity and vertical descent is controlled by lift forces. Cf. *DIVE, noun*, sense 1. 2. A descending flight path of a glide, as, a shallow *glide*.

glide, verb. 1. *intr.* To descend in a glide. 2. *intr.* To soar (which see). 3. *tr.* To put into a glide.

glide angle. Same as *GLIDING ANGLE*.

glide bomb. A bomb fitted with sustaining airfoils, sometimes an explosive-laden glider, that descends to the target in a glide. Glide bombs are often remotely controlled, and sometimes have power plants to give initial thrust or to extend the glide.

glide path. 1. The flight path of an aircraft in a glide, seen from the side. 2. In an instrument landing system, a path to be followed in the glide to a landing, as fixed by a directed radio beam; the radio beam fixing this path.

In sense 2, also called a "glide slope."

glider, noun. 1. A fixed-wing aircraft specially designed to glide, or to glide and soar. This kind of aircraft ordinarily has no power plant. See *POWER GLIDER*. 2. More restrictively, such an airplane that sinks slowly to the ground in a glide after being released from a towline or after being launched, and not capable of, or not expressly designed for, soaring flight—disting. from a *SAILPLANE*.

In sense 1, training or sporting gliders include the *primary glider*, *secondary glider*, and *performance-type glider*. (See separate entries on these.)

glide ratio. The ratio of the horizontal distance traveled to the vertical distance descended in a glide. Also called "gliding ratio."

glider tug. A powered aircraft designed or used for glider towing.

glide slope. The slope of a glide path.

gliding, noun. a. The act of descending in a glide or glides. b. The act of flying without power, of descending in glides and soaring.

Used in compounds, such as *gliding range*, *gliding speed*, *gliding turn*.

gliding, adj. That glides, or that glides and soars, as in *gliding machine*.

gliding angle. The angle between the horizontal and the glide path of an aircraft. Also called a "glide angle" or "glide slope." See *MINIMUM GLIDING ANGLE*.

gliding ratio. Same as *GLIDE RATIO*.

goldbeater's skin. A light, strong material prepared from the caecum of the ox, sometimes (esp. formerly) cemented to balloon fabric for gastightness.

gondola, noun. Specif., a car on an airship, or a pressurized car on a high-altitude balloon. See *CAR*.

gore, noun. A slim triangular panel, or a panel or piece of fabric tapered at one or both ends, one of many used, e. g., in the canopy of a parachute or the envelope of a balloon.

gosport, noun. A flexible one-way oral communication tube between two cockpits in an airplane, used esp. between a flying instructor and student.

gradient wind. A wind above the friction layer that blows parallel to curved isobars as a result of a balance of pressure forces, Coriolis forces, and centrifugal forces.

grain, noun. Specif., an elongated molding or extrusion of solid propellant for a rocket, regardless of size.

grass, noun. On a cathode-ray screen, a form of interference resembling a more or less uniform row of grass blades.

graveyard spiral. A steep, descending spiral in an airplane, involuntarily made and sometimes resulting in a crash. *Slang or colloq.*

In a graveyard spiral the aircraft is banked in a turn so that the pilot feels he is flying level. A graveyard spiral may occur in zero visibility conditions when instruments are not available or are not trusted.

grayout, noun. A temporary condition in which vision is hazy, restricted, or otherwise impaired, owing to insufficient oxygen. Cf. *BLACKOUT*, sense 1.

great circle. A circle on the surface of a sphere, esp. the earth, whose plane passes through the center of the sphere.

great-circle course. A course laid out or taken along a great circle.

greenhouse, noun. A cockpit canopy or other transparent enclosure on an aircraft. *Slang.*

gremlin, noun. Any one of a class of small goblins who haunt aircraft particularly. Although sometimes benevolent, they are mainly disruptive.

grid, adj. Of or pertaining to a grid, or related to grid north.

grid, noun. A system of lines, usually straight and parallel, superimposed on

a chart or plotting sheet to serve as a directional reference for navigation; specif., such a system designed especially for use in polar regions where convergence of the meridians causes difficulty in using geographic direction as a reference. The lines of the grid are oriented to grid north, an arbitrary reference direction.

grid bearing. Bearing measured grid north.

grid course. A course measured relative to grid north.

grid heading. Heading measured relative to grid north.

groove, noun. A glide path to a landing, esp. the glide path in an instrument landing system. *Slang.*

gross lift. 1. The total lift of an aerostat under specified conditions. 2. The total lift force acting on an airplane's wing or wings. *Rare.*

gross thrust. The total thrust of a jet engine, the drag due to the momentum of the incoming air (ram drag) not being deducted.

The gross thrust is equal to the product of the mass rate of fluid flow and the velocity of the fluid relative to the nozzle, plus the product of the nozzle exit area and the difference between static jet pressure and ambient pressure.

gross weight. The total weight of an aircraft, rocket, etc. as loaded; specif., the total weight with full crew, full tanks, payload, etc. See *DESIGN GROSS WEIGHT*.

ground, noun. The surface of the earth; specif., a land surface, as disting. from a water surface: see note.

In contexts where the distinctions are unimportant, this word may be taken to mean the earth's surface, as in "The path of an aircraft over the *ground* is called the track," or the word may mean any surface on which aircraft take off and land, as in "A plane too heavily loaded cannot get off the *ground*."

ground, verb tr. To keep on the ground, to restrict from flying, as, to *ground* a pilot or airplane.

ground-controlled approach. 1. An approach under conditions of poor visibility in which the pilot is continuously advised from the ground by radio of his position and direction as determined by radar. 2. The equipment or system used in this approach. See *PRECISION APPROACH RADAR*.

ground crew. 1. A crew that maintains and services an aircraft on the ground. 2. A *LANDING CREW*.

ground cushion. 1. Ground effect, sense 2. 2. The cylindrical volume of air which is maintained at a higher density than the surrounding air by a rotor operating in the ground effect.

ground effect. 1. The effect of the ground or surface in turning the downwash, or induced flow from the wings or rotor of an aircraft hovering or flying near it, thus reducing induced drag and increasing lift. 2. The zone close to the ground in which the ground effect (sense 1) is operative, as in "The helicopter was operating in *ground effect*".

ground loop. 1. A violent, whirling turn of an airplane while moving on the ground. Cf. **WATER LOOP**. 2. Loosely, a **NOSE-OVER**.
—ground loop, or, less often but more properly, ground-loop, verb tr. and intr. To cause to make, or to make, a ground loop, as, he *ground-looped* and came to a stop.

ground-position indicator. A flight instrument that automatically plots and indicates the position of an aircraft with respect to reference points on the ground.

ground resonance. A self-excited, mechanical, potentially destructive vibration of a rotary-wing aircraft in operation on the ground or surface, involving a coupling between the motion of the rotor blades and the motion of the supporting structure or the motion of the aircraft as a whole on its landing gear.

ground return. A reflection of radar pulses from the terrain, displayed on a cathode-ray tube.

ground roll. The ground run of an aircraft with a wheeled or track-type landing gear. See **GROUND RUN**.

ground run. The landing run or take-off run of an aircraft on the ground.

ground school. A school which gives nonflying instruction in various subjects related to flying to persons undergoing flight training.

ground speed, or groundspeed, noun. The speed of an aircraft relative to the ground, or surface of the earth. It is the same as true air speed only if the air is stationary with respect to the earth's surface.

ground-speed meter. An instrument for measuring ground speed.

ground-to-air, adj. From the ground to the air; designed to be sent from the ground to an object in the air, as in

ground-to-air projectile. Cf. **SURFACE-TO-AIR**.

group, noun. 1. An AF organization immediately superior to a squadron. 2. A Navy organization comprising the squadrons aboard an aircraft carrier. 3. An aircraft formation of varying number and pattern, usually consisting of 18 or more aircraft.

g-suit, or G-suit, noun. A suit that exerts pressure on the abdomen and lower parts of the body to prevent or retard the collection of blood below the chest under positive acceleration. Cf. **PRESSURE SUIT**.

guidance, noun. The act of guiding, of giving direction to; specif., the act of guiding or giving direction to missiles, esp. self-propelled missiles, by means of remote control, preset devices, or homing devices.

See **BEAM-RIDER GUIDANCE, CELESTIAL GUIDANCE, COMMAND GUIDANCE, HOMING GUIDANCE, HYPERBOLIC GUIDANCE, INERTIAL GUIDANCE, PRESET GUIDANCE, TERRESTRIAL REFERENCE GUIDANCE**.

guide aileron. Same as **FEELER AILERON**.

guided missile. 1. Broadly, any missile that is subject to, or capable of, some degree of guidance or direction after having been launched, fired, or otherwise set in motion. 2. Specif., an unmanned, self-propelled flying vehicle (such as a pilotless aircraft or rocket) carrying a destructive load and capable of being directed or of directing itself after launching or take-off, responding either to external direction or to direction originating from devices within the missile itself. 3. Loosely, by extension, any steerable projectile.

See **BALLISTIC MISSILE, SELF-GUIDED MISSILE**.

guide rope. Specif., a **DRAG ROPE**.

gull wing. An airplane wing which, as seen from its edge, has its inboard section at a more or less pronounced angle to the plane of symmetry and its outboard section (the longer section) at a different angle; specif., such a wing in which the inboard section has greater positive dihedral than the outboard section. See **INVERTED GULL WING**.

—gull-wing, or gull-winged, adj., as in *gull-wing(ed) sailplane*.

gust, noun. A sudden and brief change of wind speed or direction. See **SHARP-EDGED GUST**.

gust load. A load imposed upon an aircraft or aircraft member by a **gust**.

gust lock. A control lock designed especially to prevent movement of surfaces by gusts on the ground. See **CONTROL LOCK**.

gust tunnel. A tunnel in which gusts are simulated: specif., a tunnel in which models are passed over a vertical jet or jets simulating gusts.

gyration, noun. An act or instance of whirling or spinning, esp. of making a single revolution, as, the fantastic *gyrations* of the plane.

gyro, noun. 1. A clipped form of the word "gyroscope." 2. Short for "directional gyro," "gyrocompass," etc.

gyrocompass, noun. 1. [A trade name.] A compass incorporating a gyroscope whose spinning axis is parallel to the earth's axis. 2. Loosely, a **DIRECTIONAL GYRO** (in sense 1).

gyrodyne, noun. A rotating-wing aircraft whose rotor or rotors provide lift only, the system customarily being powered for take-off, hovering, landing, and for forward flight throughout part of its speed range, but usually autorotating at the higher flight speeds, forward propulsion being provided by a propeller or jet.

The gyrodyne is manufactured in a number of different varieties: with or without wings in addition to its rotor; with different mechanical arrangements for lift equalization over the rotor; with or without separate power plants for the rotor and forward-propulsion system; etc.

gyro flux gate compass. [A trade name.] A remote-indicating compass in which a "flux gate" (which see), in fixed alignment with its aircraft and horizontally stabilized by a gyroscope, senses the horizontal component of the earth's magnetic field and generates a charge in current with a change in heading, the current being amplified and used to indicate direction on a dial. See **EARTH-INDUCTOR COMPASS** and note.

gyro-horizon, noun. [A trade name; often capitalized (Gyro-Horizon).] An **ARTIFICIAL HORIZON** (in sense 1) or an **ATTITUDE GYRO** (in sense 2).

gyropilot, noun. [A trade name; sometimes capitalized.] An automatic pilot incorporating a gyroscope. See **AUTOMATIC PILOT**.

gyroplane, noun. 1. A rotating-wing aircraft, such as the autogyro, whose rotor is turned throughout its flight by the air forces resulting from the motion of the craft through the air, forward propulsion being provided independently of the rotor. 2. Specif., any such craft in which the lift on opposite sides of the rotor is equalized by varying its blade angles—so disting. from the autogyro.

gyroscope, noun. 1. A device consisting of a wheel having much of its mass concentrated around the rim, mounted on a spinning axis which is free to rotate about one or both of two axes perpendicular to each other and to the spinning axis. The gyroscope is utilized in many different instruments and systems for the tendency of its spinning axis to remain fixed in space. 2. Any of certain other devices, such as an electronic device, having certain of the properties of the common gyroscope (in sense 1).

gyro-stabilized, adj. Stabilized by a gyroscope, as in *gyro-stabilized compass, gyro-stabilized drift meter*.

gyrosyn compass. [A trade name; often capitalized.] A compass incorporating a directional gyro synchronized with the earth's magnetic meridian by means of a flux gate, the flux gate detecting the direction of the lines of force of the earth's magnetic field and transmitting corresponding signals to gyro-precessing devices.

H

habitability, noun. The state of being capable of occupation, esp. comfortably and safely, for any length of time, as, to improve the *habitability* of an airplane.

half-loop, noun. An airplane stunt or maneuver consisting of one half of a complete loop of any kind, usually one half of an inside loop begun from an upright position.

half-roll, noun. An airplane performance or maneuver in which the airplane makes one half of a complete roll, i. e., turns 180 degrees about its roll axis.

Recovery is made from a half-roll either by reversing the direction of rotation and rolling back to the original attitude, or by completing a half loop, in which case the plane recovers its original attitude but is headed in the opposite direction. See **SPLIT-S**.

A half-roll may be either a half slow roll or a half snap roll.

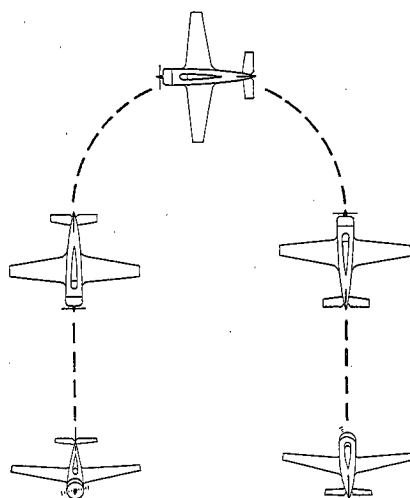

Hammerhead stall.

hammerhead stall. An exaggerated form of wing-over (which see), in which the airplane zooms into a vertical climb, stalls and yaws simultaneously, and goes into a dive from which recovery is made in a direction opposite to the original direction.

handling line. Any line for handling or towing something about, such as a line used to move an airship or balloon about on the ground, or a line used to tow a seaplane out of the water.

hand pull. Specif., a grip or handle for pulling the rip cord on a parachute.

hang, verb intr. To hang on the propeller. To climb slowly and steeply; to appear to pause in a steep nose-up position in an airplane at or near the stall.

hangar, noun. A shed, shelter, or building erected or used esp. for housing aircraft. The term may be applied to the typical barnlike structure, to a cave, to the appropriate deck of an aircraft carrier, etc.

hangar deck. A deck in an aircraft carrier where airplanes are kept.

hangar flying. The art or practice of discussing flying, recounting flying experiences, etc. *Popular.*

harness, noun. AN IGNITION HARNESS, MOORING HARNESS, PARACHUTE HARNESS, OR SHOULDER HARNESS.

hatch, noun. A covered opening in an aircraft, esp. in the top or bottom of the fuselage or hull—a general term, but not applied to full-sized doors in the side of the aircraft. See ESCAPE HATCH.

haze, noun. A light suspension of water vapor, smoke, or other fine particles in the atmosphere, sufficient to reduce visibility.

head, noun. 1. The top or front end or part, or the central part, of something, as of a piston, of a combustion chamber in a reciprocating engine, of a rotor, of an aircraft (*chiefly naval usage*), etc. See ROTOR HEAD, WARHEAD. 2. *Physics.* a. A measure of fluid pressure as the height of a liquid column necessary to cause that pressure at its base; the pressure of a fluid owing to its elevation. b. By extension, the energy per unit weight, or some component of this energy, exerted by a fluid; total head. See ELEVATION HEAD, PRESSURE HEAD, sense 1, TOTAL HEAD, VELOCITY HEAD. 3. A probe-like device that projects into a field of flow to measure pressures or to sense the flow direction. See AIRSPEED HEAD, PITOT-STATIC HEAD, YAWHEAD.

header, noun, or header tank. The upper tank in a cooling system.

heading, noun. The horizontal direction in which a craft points as it flies through the air, usually expressed as an angle measured clockwise from some reference direction to the longitudinal axis of the craft. Thus heading often does not coincide with course or track because of drift or yaw.

See COMPASS HEADING, GRID HEADING, MAGNETIC HEADING, TRUE HEADING.

head resistance. 1. The resistance exerted by the air against the front of an aircraft or other body moving through it, proportional to its frontal area. 2. The frontal air resistance associated with parasite drag (in the older sense of that drag). *Obs.*

headrest, noun. A cushion or support for the head. On an open-cockpit airplane, the headrest is typically a half-cone atop the fuselage tapering away from the rear edge of the cockpit, giving support to the back of the head.

headset, noun. A clamp or helmet holding an earphone or pair of earphones.

head-to-foot acceleration. *Av. med.* 1. Accelerating force acting on the body in the direction from the head to the foot; acceleration in the direction that this force is applied; also, HEAD-TO-SEAT ACCELERATION. 2. An inertial force acting in the direction from the head to the foot. *Rare.* See ACCELERATION, sense 3 and final note.

head-to-seat acceleration. *Av. med.* 1. Accelerating force acting on the body in the direction from the head to the seat, as occurs, e. g., when seated in an airplane nosing over into a dive; acceleration in the direction that this force is applied. Sometimes called "negative acceleration" (which see). 2. An inertial force acting in the direction from the head to the seat. *Rare.* See ACCELERATION, sense 3 and final note.

head wind, or headwind, noun. A wind blowing from directly ahead, or blowing from a forward direction such that its principal effect is to reduce ground speed.

heat barrier. The THERMAL BARRIER.

heat engine. An engine that converts the energy of heat into mechanical or kinetic energy, such as steam and internal-combustion reciprocating and turbine engines, rocket engines, ramjet engines, etc.

heat exchanger. A device for transferring the heat from one fluid to another without intermixing the fluids, as: a. A muff or other device in an aircraft-engine exhaust system that utilizes the exhaust heat to heat air for de-icing or cabin heating. b. A REGENERATOR. c. An apparatus for cooling or heating the air in a wind tunnel.

See RADIATOR, sense 2 and note.

heat sink. a. In thermodynamic theory, a means by which heat is stored, or is dissipated or transferred from the system under consideration. b. A place toward which the heat moves in a system.

heat-transfer coefficient. A coefficient expressing the ratio of the rate of heat transfer per unit area of a body or substance to the temperature differential.

heavier-than-air, adj. 1. Of aircraft: Weighing more than the air displaced and deriving lift solely by aerodynamic means. See HEAVIER-THAN-AIR AIRCRAFT, note, and cf. HEAVY. 2. Of, pertaining to, or dealing with, heavier-than-air aircraft, as in *heavier-than-air flight*, *heavier-than-air pilot*.

This term is hyphenated only as an attributive adjective.

heavier-than-air aircraft. Aircraft, or an aircraft, weighing more than the air displaced and designed to fly solely by aerodynamic means. A heavier-than-

air aircraft is also called an "aerodyne."

While airships can be, and often are, flown weighing more than the displaced air, they are not thus classified as "heavier-than-air aircraft."

heavy, adj. Of an airship: Heavier than the surrounding air;—also used adverbially, as, to fly *heavy*.

hedge-hop, verb intr. To fly very low to the ground, rising over hedges, trees, houses, etc. as they block the path. *Slang or popular.*

height, noun. 1. Vertical distance; the distance above some reference point or plane, as, *height* above sea level. See ALTITUDE, PRESSURE HEIGHT. 2. The vertical dimension of anything; the distance which something extends above its foot or root. See BLADE HEIGHT. 3. The measure of vertical distance or dimension.

helical scanning. Radar scanning in which a point on the beam traces a helical path in space, the radar antenna revolving and simultaneously changing its angle of elevation.

helicopter, noun. [*Pronounced "hella-copter,"* or, infrequently, "heelacopter."] a. Originally, any heavier-than-air aircraft supported in the air by power-driven rotors about one or more substantially vertical axes. b. As eventually developed, such an aircraft with which horizontal movement is achieved by controlling these power-driven rotors so as to create a component of thrust in the desired direction of flight. By virtue of its mechanical design, a modern helicopter, in addition to being capable of hovering and of taking off and landing vertically, is capable of moving horizontally in any direction without a corresponding change in heading. See ROTARY-WING AIRCRAFT.

helicopter test tower. A tower upon which helicopter rotors are mounted and driven for testing under controlled conditions.

helimail, noun. Mail carried by helicopter.

heliport, noun. An airport or airdrome for helicopters. Because of the lack of necessity for long runways, a heliport is of comparatively small dimensions.

helium, noun. A gaseous element, lighter than air, much-favored for use in balloons and airships for its nonflamma-

bility. It provides a lifting force of roughly 60 pounds per 1000 cu. ft. under standard conditions at sea level.

helix angle. In specific uses: 1. The angle of the helix along which a point on a propeller blade actually moves, measured with respect to a plane perpendicular to the axis of rotation. 2. The angle of the helix described by a point on an airplane wing, esp. a wing tip, as the airplane rolls in forward flight. The tangent of this helix angle is $pb/2V$, where p is the rolling velocity in radians per second, b is the span in feet, and V is the forward velocity in feet per second. 3. In spinning, the angle between the flight path and the spin axis.

helmet, noun. a. Any special piece of headgear designed to protect the wearer in one way or another, and often incorporating special apparatus such as earphones. See CRASH HELMET. b. Originally and typically, a leather cap, often fur-lined, with ear flaps, chin strap, and goggles, designed for wear in open or open-cockpit airplanes.

H-engine, noun. A reciprocating in-line engine with four banks of cylinders, two upright and two inverted, which, together with the common central shaft, form the letter "H" in end view.

high altitude. An altitude considered in context to be comparatively high.

Sometimes given specific definition, "high altitude" is properly a relative term. It is used particularly to designate any altitude high enough that atmospheric tenuity, low temperature, distance to earth, etc. become of significance in the design, operation, or behavior of aircraft or aircraft equipment, or in the functioning and behavior of the human body.

high-altitude, adj. 1. Performed or conducted at a high altitude, as in *high-altitude* bombing, *high-altitude* flight. 2. Designed for operation or use at high altitudes, as in *high-altitude* aircraft, *high-altitude* engine, *high-altitude* rocket. 3. Established or occurring at a high altitude, as in *high-altitude* route.

Note: In some terms, "altitude" is reserved for "high altitude," as in *altitude* engine, *altitude* sickness.

high-lift device. Any device, such as a flap, slat, or boundary-layer-control device, used to increase the lift of a wing.

high-performance sailplane. A PERFORMANCE-TYPE GLIDER.

high pitch. The pitch of a propeller or propeller blade at a large blade angle other than the feathering angle.

high speed. A comparatively fast speed.

A relative term, "high speed" is often used to designate any speed high enough that special problems arise, as in aerodynamics, navigation, maneuvering, the operation of pressure instruments, etc.

—*high-speed, adj.*, as in *high-speed* aerodynamics, *high-speed* aircraft, *high-speed* bailout, *high-speed* cowling, *high-speed* flight, *high-speed* stall, *high-speed* wind tunnel, etc.

high-wing monoplane. A monoplane whose wing is mounted directly at the top of the fuselage, or above the fuselage; specif., a monoplane having its wing or wing halves mounted directly to the fuselage at the top. Cf. PARASOL MONOPLANE, SHOULDER-WING MONOPLANE.

hinged rotor. AN ARTICULATED ROTOR.

hinge moment. The tendency of a force to produce movement about a hinge; specif., the tendency of the aerodynamic forces acting on a control surface to produce motion about the hinge axis of the surface; the measure of such tendency. See MOMENT.

hinge-moment coefficient. In aerodynamics, a coefficient representing the hinge moment produced by the aerodynamic forces acting on a control surface, defined by the equation $C_h = \frac{H}{qbc^2}$,

where H is the hinge moment, q is the dynamic pressure, b is the span, and c is the root-mean-square chord.

hog, verb intr. Of an airship or flying boat: To bend upward in the middle, the ends drooping. Cf. SAG.

—*hog, noun*, as, to examine for *hog*.

hold, noun. 1. A compartment below the deck or floor of an aircraft for mail, luggage, etc. 2. An act or instance of holding.

hold, verb intr. To wait. Specif.: a. To circle or fly about in a particular pattern near a specified point while waiting for permission or instructions to land or to proceed along a course. b. To delay taking off until permission is received.

holding fix. A HOLDING POINT.

holding pattern. A particular or specified pattern flown while holding.

holding point. A specified point near which an aircraft holds, flying its holding pattern. Also called a "holding fix."

home, verb intr. 1. To follow a path of energy waves, esp. radio or radar waves, by means of a directional antenna, radar equipment, or other suitable equipment, to or toward the point of transmission of the waves. Said of persons or aircraft. 2. Of a guided missile: To follow a path of energy waves transmitted, radiated, or reflected from a target, using sensing devices incorporated within the missile. The energy waves used may be infrared rays, radio or radar waves, sound waves, etc. See HOMING, note.

In both senses, the verb is followed by *on*, as, to home *on* a beacon, target, etc.

homing, noun. The following of a path of energy waves to or toward their source. See HOME.

See ACTIVE HOMING, PASSIVE HOMING, SEMIACTIVE HOMING.

homing adapter. A device used with a radio receiver to enable homing with the set.

homing guidance. The guidance of a missile by means of a self-contained mechanism that is activated by a sensing device responding to some kind of emanation from the target.

honeycomb, noun. 1. A grid of intersecting surfaces or a close arrangement of parallel passages used to straighten or control the flow in a wind tunnel. 2. The core of a radiator.

honeycomb-core sandwich construction. A type of construction for aircraft wings, stabilizers, or the like in which the space between the upper and lower surfaces is occupied by a strengthening material of a structure resembling a honeycomb mesh.

hood, noun. A covering of one kind or another, as: a. An opaque screen fitted around a cockpit or cabin so that the pilot cannot see out, used for training in blind flying. b. A panel or cover protecting or streamlining an engine, such as the circular covering in an NACA cowling. c. A hatch cover. d. A kind of bonnet or cap sheltering a gas valve on a balloon or airship.

hook, noun. Specif., the hook in an arresting gear. See ARRESTING GEAR.

hop, noun. In popular usage: a. The flight of an aircraft from one point directly to another, either as a complete journey or as one stage of a journey consisting of several such flights. b.

More rarely, a flight beginning and ending at the same place, as in a test flight or hop.

hopper, noun. Specif., a separate compartment or reservoir in an engine's oil tank that segregates the oil being circulated through the engine from the rest of the oil for rapid heating during warm-up.

horizon, noun. 1. The line, regarded as smooth and even, where earth and sky appear to meet. 2. A plane passing through the eye of an observer, perpendicular to the vertical at a given place. 3. a. A line on an artificial horizon or attitude gyro representing the horizon; short for ARTIFICIAL HORIZON. b. A BUBBLE HORIZON OR CELESTIAL HORIZON. 4. A RADAR HORIZON.

horizon bar. The gyro-stabilized line or bar in an artificial horizon.

horizontal, noun. A plane or line perpendicular to an extension of the earth's radius at the point of observation.

horizontal, adj. 1. Parallel to the horizon or to the horizontal. See HORIZON, HORIZONTAL, *noun*. 2. Parallel, or approximately so, to a plane containing the longitudinal and lateral axes of an aircraft.

horizontal fin. Any one of the horizontal stabilizing surfaces mounted on the side of an airship—rarely applied to the corresponding part on an airplane. Cf. HORIZONTAL STABILIZER.

horizontal stabilizer. A stabilizer mounted more or less horizontally on an airplane, airship, or other aircraft, affording longitudinal stability, and to which the elevators, when present, are attached. Cf. VERTICAL STABILIZER.

This term is applied to any one of the horizontal fins (see HORIZONTAL FIN) on either side of an airship, or to a corresponding surface or lobe on a kite balloon, but in reference to an airplane it is most often applied to the entire stabilizing surface extending on both sides of the plane or symmetry. See STABILIZER, note and cf. TAIL PLANE.

horizontal tail. The entire horizontal part of an aircraft's empennage extending on both sides of the plane of symmetry and in most forms comprising both fixed and movable surfaces. Cf. TAIL PLANE.

horizontal tail area. The area of the horizontal tail of an aircraft, including the area blanketed by the fuselage, hull, or boom. b.

With more or less conventional horizontal tails, the blanketed area is included within lateral straight lines connecting the leading and trailing edges of the stabilizer, the additional area of fairings and fillets being ignored; with some tails, e. g., a sweptback tail, the blanketed area may be chosen to lie within other significant lines.

horn, noun. 1. A projection or a projecting part, as from an aircraft control surface. See CONTROL HORN, HORN BALANCE. 2. A device for making a distinctive warning sound, usually loud and raucous, as on an aircraft to warn of an imminent stall or to warn of the position of the landing gear. 3. *Electronics.* An electronic component, such as an antenna or tube, of varying sectional area such that in shape it resembles an animal's horn or a musical horn.

horn balance. A part of a control surface of longer chord than the rest of the surface, lying forward of the hinge line and usually at the outboard end of the surface, used for aerodynamic balance.

horsepower, noun. A unit of power equal to the power necessary to raise 33,000 pounds one foot in one minute. Thus, an engine of 1,000 horsepower develops 1,000 × 33,000 foot-pounds of work per minute.

See BRAKE HORSEPOWER, EQUIVALENT SHAFT HORSEPOWER, FRICTION HORSEPOWER, INDICATED HORSEPOWER, PROPELLER-LOAD HORSEPOWER, RATED HORSEPOWER, SHAFT HORSEPOWER, THRUST HORSEPOWER.

horsepower-hour, noun. One horsepower delivered for one hour.

horseshoe vortex. In aerodynamic theory, a system of vortices consisting of a bound vortex with a trailing vortex springing from each of its ends, the system replacing an airfoil for purposes of simplification in certain aerodynamic problems.

hostess, noun. A stewardess. See STEWARD.

hot-air balloon. A balloon that uses heated air as the aerostatic agent. Such a balloon may obtain heated air on the ground only, or it may carry a fire along during its flight. Cf. FIRE BALLOON and see MONTGOLFIER.

hot-gas bleedback. A method of preventing icing in an engine or intake by mixing the entering air with hot air or gases bled from the engine after compression or after combustion. Used esp. with gas-turbine or jet engines.

hot spot. A spot, place, or part more highly heated than the surrounding material, such as a place of intense heat in an engine cylinder, often causing preignition.

hot start. The start of a jet engine in which the temperature of the exhaust pipe rises to an abnormally high and unsafe degree.

hot-wire anemometer. An anemometer, (which see) the active element of which is an electrically heated wire, the heat transfer from which is affected by wind speed, temperature and density of the flow past the wire.

hover, verb. 1. *intr.* a. Of a helicopter, airship, etc.: To remain stationary at a given height, moving neither vertically nor horizontally. b. To remain at height maintaining zero horizontal and zero vertical velocity relative to the air. See note. 2. *tr.* To operate (an aircraft) so as to remain stationary at height.

In sense 1b, hovering takes place with respect to the relative wind, rather than the ground. Said esp. of a helicopter.

hovering, noun. The action of remaining stationary in the air.

—hovering with ground effect. Hovering in a helicopter or the like near enough to the ground to derive increased lift from the ground effect. See GROUND EFFECT.

—hovering without ground effect. Hovering not near enough to the ground to derive increased lift from the ground effect.

hovering, adj. That hovers, as in *hovering* helicopter.

hovering ceiling. The maximum altitude at which a rotary-wing aircraft can hover under the given conditions.

howgozit, noun. ["How goes it."] A graph kept in cruise control on which fuel consumption is plotted against distance flown.

hub, noun. The central part or portion of a wheel, propeller, or similar rotary object; the drum or disk of a compressor or turbine rotor. See PROPELLER HUB, ROTOR HUB.

hub dynamometer. A type of dynamometer built into the hub of an aircraft-engine propeller for measuring thrust, torque, or both thrust and torque.

hub-tip ratio. The ratio of the diameter of the hub of a compressor rotor or turbine wheel to its tip diameter.

hull, noun. 1. The main body of an airship or flying boat. See AIRSHIP HULL, SEAPLANE HULL. 2. The outer shell or

casing of a rocket projectile, esp. of a large rocket projectile.

hull displacement. Specif., the volume or weight of the water displaced by a seaplane hull.

humidity, noun. Moisture or water vapor in the air. See ABSOLUTE HUMIDITY, RELATIVE HUMIDITY.

hump, noun. 1. A peak in a line on a graph. 2. Figuratively, the point at which a seaplane meets its greatest resistance in moving through the water in taking off.

hump resistance. The resistance of a seaplane to the water at the hump (which see, sense 2), as, a hull with low *hump resistance*.

hump speed. The speed during the take-off run of a seaplane at which the water resistance is at a maximum. See HUMP, sense 2.

hunt, verb intr. To swing back and forth or to oscillate, esp. rather slowly, as: a. Of an aircraft, rocket, etc.: to weave about its flight path, as if seeking a new direction or another angle of attack; specif., to yaw back and forth. b. Of a control surface: To rotate up and down or back and forth without being deflected by the pilot. c. Of a control system: To oscillate about a selected value.

hurdle, noun. An obstruction on the ground over which a student pilot is required to land to develop his skill.

hydraulic accumulator. An accumulator (which see) in a hydraulic system.

hydraulic control booster. A control booster operated hydraulically. See CONTROL BOOSTER.

hydraulic radius. In the study of flow in ducts and channels, the cross-sectional area of the fluid stream divided by the wetted perimeter of the duct or channel.

hydraulics, noun. 1. Specif., that branch of mechanics or engineering that deals with the action or use of liquids forced through tubes and orifices under pressure to operate various mechanisms. 2. Hydraulic apparatus, as, to use *hydraulics* to operate an aircraft control system.

hydroairplane, noun. A floatplane or flying boat. *Rare.*

hydrodynamics, noun. The science that deals with the motion or action of water and other liquids, and of the

forces acting on bodies in motion in liquids.

Related to gas dynamics, hydrodynamics in many respects provided a foundation for modern aerodynamics.

hydroflap, noun. A hydrofoil attached to a seaplane float or hull, used as a brake, rudder, or planing surface.

hydrofoil, noun. A structure or body similar to an airfoil, but designed to act in water.

hydrogen, noun. An element usually isolated as a colorless, odorless, tasteless, flammable gas. Lighter than any other element, hydrogen as used in balloons and airships provides a lifting force of roughly 65 pounds per 1,000 cu. ft. under standard conditions at sea level. It has fallen into disfavor as an aerostatic gas because of its flammability.

hydromatic propeller. A constant-speed propeller hydraulically operated.

hydroplane, noun. 1. A hydrofoil designed to skim the surface of the water. 2. A HYDROAIRPLANE. *Rare.* 3. A boat designed to ride on the surface of the water when in motion, deriving much of its support from hydrodynamic action.

hydroplane, verb intr. To move on the surface of the water supported chiefly by dynamic forces.

hydroski, noun. A kind of hydrofoil or hydroplane of low aspect ratio, similar to a ski, used in an airplane landing gear to support the airplane when moving at high speed on the water.

hydrovane, noun. 1. A vane designed to act in water or other liquid. 2. A HYDROFOIL. *Obs.*

hyperbolic guidance. The guidance of a missile or the like in which radio signals, transmitted simultaneously from two ground stations, arrive at the guided object with a constant time difference, thereby establishing a hyperbolic path which the object follows.

hyperbolic navigation. Radio navigation in which a hyperbolic line of position is established by signals received from two stations at a constant time difference.

hypergolic propellants. Rocket propellants that ignite spontaneously when mixed with each other.

hypersonic, adj. Of or pertaining to hypersonics.

hypersonic flow. Flow at very high supersonic speeds; as arbitrarily defined, flow at a Mach number of 5 or greater.

hypersonics, noun. That branch of aerodynamics that deals with very high supersonic speeds, sometimes defined

as dealing with Mach numbers of 5 or greater.

hypoxia, noun. Med. A deprivation of oxygen, esp. a deprivation of oxygen extensive enough to cause impairment of the physical faculties. See ANOXIA.

I

ice, verb intr. To ice up. To become coated with ice—said of aircraft surfaces, air-induction systems, etc.

ice detector. Same as ICE-WARNING INDICATOR.

ice-warning indicator. An instrument that detects the presence of ice or icing conditions and gives indication.

icing, noun. 1. The action or process by which atmospheric moisture is deposited as ice; the condition under which this occurs, as, to encounter *icing*. 2. An accretion of ice.

icing level. A level or altitude at which icing occurs under the given conditions; specif., the minimum altitude at which icing may occur.

ideal angle of attack. The angle of attack of an airfoil at which the airflow meets the leading edge smoothly, resulting in a zero pressure differential across the leading edge.

ideal fluid. A PERFECT FLUID.

identification light. Any light or group of lights mounted on an aircraft for identification.

idle, verb tr. To run (an engine) slowly at a certain predetermined rotational speed, usually just sufficient to insure continued running.—*intr.* To rotate slowly at a preset speed—said of an engine or its propeller.

idle cut-off. A device that shuts off the flow of fuel to a carburetor, stopping the engine; the position of the mixture controls that results in this shutting off.

IFR—Abbreviation for *Instrument Flight Rules*—also used as an adjective or adverb, as in *IFR* traffic, or as, to fly *IFR*.

igniter, noun. Any device used to begin combustion, such as a spark plug in the combustion chamber of a jet engine, or a squib used to ignite the fuel in a rocket.

ignition delay. The time lapse occurring between the instance of an igniting action of a fuel and the onset of a specified burning reaction. Also called "ignition lag."

In a compression-ignition engine, the time interval is measured between the commencement of fuel injection and the occurrence of a measurable pressure rise caused by combustion.

ignition harness. The system of high-tension wiring, together with any conduits or shielding, between the distributor and spark plugs of an engine.

ignition lag. Same as IGNITION DELAY.

ILS—Abbreviation for *instrument landing system*.

ILS marker. A location marker in an instrument landing system. See LOCATION MARKER.

Immelmann, noun, or Immelmann turn. [After Max Immelmann (1890-1916), German aviator.] An airplane maneuver in which the plane makes an inside half-loop and then makes a half-roll back to its original upright position, thus changing direction by 180° and simultaneously gaining altitude. The Immelmann turn is a form of reversal.

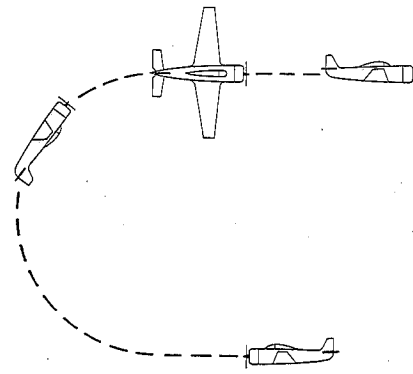

Immelmann.

impact acceleration. A sudden acceleration caused by impact, as occurs, e. g., in a crash landing.

impact air pressure. The impact pressure of air. See IMPACT PRESSURE.

impact basin. A water-filled channel in which model seaplane floats and hulls are set down at speed from an overhead traveling rig to simulate the loads imposed on landing; the complete facility where this basin is housed, i. e., the basin, shed, overhead carriage, etc.

impact ice. Ice which forms when snow, sleet, or supercooled water droplets impinge upon aircraft surfaces, etc. which are at or below freezing temperature.

impact load. A load imposed upon a body by impact, e. g., a load imposed when an aircraft strikes the ground in landing.

impact pressure. That pressure of a moving fluid brought to rest which is in excess of the pressure the fluid has when it does not flow, i. e., total pressure less static pressure. Impact pressure is equal to dynamic pressure in incompressible flow, but in compressible flow impact pressure includes the pressure change owing to the compressibility effect.

impact tube. In a carburetor, one of a battery of open-ended tubes pointing upstream at the entrance of the main venturi, supplying the air pressure for a diaphragm that controls the fuel-inlet valve.

impeller, noun. A device that imparts motion to a fluid; specif., in a centrifugal compressor, a rotary disk which, faced on one or both sides with radial vanes, accelerates the incoming fluid outward into a diffuser; also, that part of a centrifugal compressor comprising this rotor and its housing. See CENTRIFUGAL COMPRESSOR.

impeller blade. Same as IMPELLER VANE.

impeller vane. Any one of the vanes on the impeller of a centrifugal compressor, serving to take in air and accelerate it radially outward. Cf. COMPRESSOR BLADE.

impeller wheel. The vaned rotor in a centrifugal compressor. Usually called the "impeller" (which see).

impinging-stream injector. In a liquid-propellant rocket engine, a device that injects the fuel and oxidant into the

combustion chamber in such a manner that the streams of fluid intersect one another.

impulse, noun. Specif., the product of the average thrust of a jet-reaction engine and the time during which it acts. Also called "total impulse." See SPECIFIC IMPULSE.

impulse turbine. A type of turbine having rotor blades shaped such that the wheel is turned from the impact of the fluid against the blades, no pressure drop occurring across the blades. Cf. REACTION TURBINE.

inboard, adj. Close to the fuselage, hull, or center line; closer to the center than another (component or section), as in *inboard flap*; closest to the fuselage or hull.

inboard, adv. Near the center, or the fuselage or hull, as, a stall that begins *inboard*; toward the center line, as, to be directed *inboard*.

inboard engine. The engine on either side of an airplane that is the closer or closest to the fuselage or hull.

inboard stabilizing float. A stabilizing float mounted on the wing close to the main float or the hull.

inboard wing. That portion of a wing near the fuselage or hull.

incidence, noun. Specif. (also *incidence angle*), the ANGLE OF INCIDENCE.

inclinometer, noun. Specif., an instrument for indicating or measuring the angle between an aircraft's longitudinal or lateral axis and the horizontal. Cf. CLINOMETER.

incompressible flow. In aerodynamics, flow in which the density changes are insignificant, as occurs throughout most of the range of subsonic flight.

indicated airspeed. The airspeed measurement as shown by any type of airspeed indicator. See AIRSPEED and note, AIRSPEED INDICATOR and note.

indicated altitude. Altitude as shown by any altimeter. With a pressure, or barometric, altimeter it is altitude as shown by the reading uncorrected for instrument error and uncompensated for variations from standard atmospheric conditions.

indicated horsepower. The computed total horsepower an engine develops, equal to the sum of the brake horsepower and the friction horsepower.

indicated mean effective pressure. The average working pressure developed within the cylinders of an engine during the power stroke. The indicated mean effective pressure is based on the indicated horsepower of the engine, and therefore is the sum of the friction mean effective pressure and the brake mean effective pressure.

indicated pressure altitude. Altitude above the standard datum plane (29.92" Hg) shown by a pressure altimeter. See PRESSURE ALTITUDE, sense 1.

indicated specific fuel consumption. Specific fuel consumption based on indicated horsepower. See SPECIFIC FUEL CONSUMPTION and note.

indicated thermal efficiency. Thermal efficiency based on indicated horsepower, expressed as the ratio of the work done on the pistons of an engine in a given period of time to the total heat energy contained in the fuel burned during the same period of time. See THERMAL EFFICIENCY.

indicator, noun. 1. Any device that indicates something, such as wind indicator; a device, such as a light or horn, that indicates or warns of something, such as, in an aircraft, the imminence of a stall, the position of the landing gear, etc. 2. An instrument, esp. that part of an instrument or system that displays its measurements or indications, such as an air-position indicator, an airspeed indicator, a rate-of-climb indicator, etc.

indicator card. A card with a diagram representing the pressure variations occurring inside the cylinder of an engine. It is used in determining indicated horsepower.

indraft wind tunnel. A wind tunnel through which air is drawn by means of a low-pressure tank. Cf. INDUCTION WIND TUNNEL.

induced angle. Also, induced angle of attack. The difference between the actual angle of attack of an airfoil and the angle of attack for infinite aspect ratio for the same lift coefficient, i. e., the angle between the direction of movement of the airfoil and the resultant wind past it.

induced drag. In subsonic flow over a finite airfoil or other body, that part of the drag caused by lift, i. e., induced by the downwash.

induced flow. Flow drawn or sucked in, as the flow induced by the vortex system of a rotor, or the flow of air or mixture sucked into an engine by the action of the pistons.

induced velocity. 1. A velocity increase over that of the free-air stream caused by the presence of a body in the stream. 2. The velocity of the induced flow through a rotor.

inducer, noun. The inlet section of a centrifugal-flow impeller, having the vanes bent in the direction of rotation for smooth air entry—esp. so called when this is a distinct, attached section.

induction system. The system of inlets, ducts, scoops, etc. by means of which air or mixture is taken in and conveyed to an engine. a. In a reciprocating engine, the system of air scoops, air ducts, superchargers, carburetors, manifolds, etc.; sometimes restricted to the system through which the fuel-air mixture passes between the carburetor and the combustion chamber. See ROTARY INDUCTION SYSTEM. b. In a gas-turbine engine, the inlets, ducts, etc. through which the air flows to the compressor.

induction-system icing. Icing upon or within an induction system. It may be made up of fuel-evaporation ice, impact ice, or throttle ice.

induction wind tunnel. A type of tunnel in which a flow of air through the test section is induced by a high-velocity jet injected into the tunnel downstream of the test section. Cf. INDRAFT WIND TUNNEL.

inertial guidance. The guidance of a missile by means of self-contained devices that activate control mechanisms by their response to inertial reactions to accelerations.

infinite-span wing. In aerodynamic theory, a wing of endless-span, thus having no tip vortices nor induced drag, assumed for purposes of simplification.

inflate, verb tr. To fill or fill out with gas or air, as, to *inflate* a balloon or gasbag, a parachute, etc.—*intr.* Of a parachute: To distend.

inflation net. A net put over a balloon to restrain it only during inflation.

inflation sleeve. A flexible fabric duct on a balloon, airship, or gasbag for inflating it with a buoyant gas. See APPENDIX.

in-flight, adj. Occurring, performed, or used during flight, as in *in-flight* icing, *in-flight* operation.

in-flight refueling. Same as AIR REFUELING.

inflow, noun. A flow inward; specif., the total flow of air through a rotor or propeller disk, including both induced flow and flow owing to the translational movement of the rotor or propeller.

inflow angle. The angle between the direction of movement of a rotor blade (free stream) and the direction of the resultant wind past the blade, measured in a plane perpendicular to the blade-span axis.

inflow ratio. The ratio of the speed of inflow through a rotor to the rotor-tip speed.

inhabited vehicle. A vehicle (e. g., an airplane or rocket) carrying a person or persons.

inherent stability. The stability of something inherent in its design and construction; specif., with an aircraft, that built-in stability that causes the aircraft, when disturbed from a condition of steady flight, to return to that condition without corrective action being necessary.

initial approach. In instrument landing, the approach or holding pattern flown by an aircraft preparatory to the final approach.

This term is sometimes more specifically defined in pertinent directives, instruction manuals, and the like.

initial mass. Specif., the mass of a rocket propelled vehicle, at launch.

initial velocity. The velocity of anything at the beginning a specific phase of its motion.

injection, noun. Specif., the introduction of fuel, fuel and air, fuel and oxidant, water, or other substance into an engine induction system or combustion chamber. See FUEL INJECTION, WATER INJECTION.

injection carburetor. A type of carburetor in which fuel is atomized under pressure other than atmospheric. Sometimes called a "pressure-injection carburetor."

injector, noun. A device that injects fuel or propellant into a combustion chamber under pressure other than atmospheric. See IMPINGING-STREAM INJECTOR, UNIT INJECTOR.

inlet, noun. An entrance or orifice for the admission of fluid; specif., an AIR INLET.

Frequently used in compounds, such as inlet air, inlet-air temperature, inlet casing, inlet duct, inlet guide vane, inlet port, inlet valve, etc.

in-line engine. An internal-combustion reciprocating engine with its cylinders arranged in one or more straight lines.

inner cone. The cone-shaped component situated just behind the turbine wheel in an exhaust cone. See EXHAUST CONE.

inner liner. Specif., a flame tube mounted coaxially inside the outer cover or shell of a combustion chamber. Also called a "flame tube" (which see) or a "combustion-chamber liner."

inside loop. A loop, usually begun from an upright flying position, in which the airplane's back is toward the inside of the loop.

inspection door. A small door, as in an aircraft, used especially for inspection of the interior.

—inspection hole, inspection window.

instability, noun. 1. The condition of a body if, when displaced from a state of equilibrium, it continues, or tends to continue, to depart from the original condition. See SPIRAL INSTABILITY and cf. STABILITY. 2. COMBUSTION INSTABILITY. 3. Meteorol. The condition that exists in a body of air when the air within it is easily displaced in a vertical direction, the individual air particles, if displaced, tending to move with increasing speed from their original level.

installation error. Specif., an error in a pitot-static system owing to the location of the responsive element with respect to other aircraft components thus affecting the measurements of the pitot-static instruments.

instrument, noun. With respect esp. to aircraft, rockets, etc. and navigation: a. A measuring device or apparatus, as a meter, gauge, or the like, that shows, or that is used to ascertain, measurements regarding the flight, movement, position, attitude, or altitude of an aircraft, missile, etc. or measurements regarding fuel quantities and the like, or regarding the operation of components and systems. "Instrument" in this sense applies to airspeed indicators, altimeters, rate-of-climb indicators, tachometers, voltmeters, manifold-pressure

gauges, flap-position indicators, driftmeters, sextants, etc. b. Any of certain related or associated devices, such as a compass or an automatic pilot, whose ultimate or chief function is something other than measuring.

See AIRCRAFT INSTRUMENT.

instrument approach. An approach during which the pilot is dependent entirely upon instruments and ground-based electronic and communication systems for orientation, position, altitude, etc.

instrument board. Same as INSTRUMENT PANEL.

instrument error. The error inherent in a particular instrument, such as an altimeter or airspeed indicator, owing to variations in spring tension, diaphragm flexibility, etc.

Instrument Flight Rules. [*Sometimes, though rarely, not capitalized.*] Rules specified by qualified authority for flight under weather conditions such that visual reference cannot be made to the ground and the pilot must rely on instruments to fly and navigate.

instrument flying. Flying using instruments to determine position, orientation, etc. under conditions of limited visibility.

instrument landing. A landing under conditions of little or no visibility, made using instruments and ground electronic aids to determine position, altitude, etc.

instrument landing system. A radio-guidance and communication system designed to guide aircraft through approaches, letdowns, and landings under conditions of little or no visibility. The instrument landing system consists essentially of directional radio transmitters establishing the angle of the glide path and indicating the direction of the runway, and of radio marker beacons establishing locations along the approach path.

instrument panel. A panel or board containing instruments, or instrument dials, typically, on an aircraft, such as a panel mounted ahead of, and easily visible to, the pilot. Also called an "instrument board."

instrument rating. A rating authorizing a pilot to do instrument flying.

intake, noun. An opening for taking in fluid; an inlet; specif., an AIR INTAKE.

Frequently used in compounds, such as intake air, intake drag, intake duct, etc.

intake stroke. In a four-stroke-cycle engine, the stroke or movement of a piston during which the fuel-air mixture is introduced or drawn into the cylinder. Sometimes called the "suction stroke."

integral fuel tank. A structural configuration in which a component of the airframe such as wing or fuselage serves as a fuel container.

integrating accelerometer. A mechanical-electrical accelerometer that integrates the measurements of the various accelerations to which a body is subjected.

intensifier tube. A tube inserted in an exhaust manifold for the purpose of heating air passing through the tube and conveying it to a carburetor for de-icing or anti-icing.

intercept, noun. 1. An act or instance of meeting a moving aircraft, missile, etc. 2. *Nav.* The difference between computed and observed altitudes.

intercept bearing. The bearing maintained by an aircraft, a projectile, etc. so that it may meet another moving object.

interceptor, noun. 1. An aircraft or missile used for intercepting, esp. a fast, well-armed airplane for intercepting and destroying enemy bombers. 2. A lateral-control device placed just behind a wing slot to spoil the effect of the slot at high angles of attack.

interceptor missile. A guided missile, esp. one launched from the ground, intended to intercept and destroy aircraft or other missiles.

intercom, noun. A voice-communication system between or among different stations or places in an aircraft, a building, an office, etc.; a transmitter, a receiver, or a combination transmitter-receiver used in this system.

intercontinental, adj. 1. Capable of traveling nonstop between continents, as in *intercontinental* bomber, a bomber capable of flying from one continent to another, with or without air refueling, *intercontinental* missile, a missile than can be fired from one continent to another. 2. Of or pertaining to intercontinental aircraft or travel between continents, as in *intercontinental* airport.

intercooler, noun. A cooler for a fluid between two stages of some process in

which the fluid acquires heat, e. g., a cooler between two stages of supercharging in the induction system of an aircraft engine. Cf. **AFTERCoolER**.

interference, noun. In aerodynamics, that which occurs when surfaces or bodies influence the flow around others, as, the *interference* between the two wings of a biplane, or between two fins of a rocket. See **PROPELLER INTERFERENCE**.

interference drag. Drag owing to the interference of the airflow around aircraft components close to one another. Specifically, it is the drag of the combination minus the drag of the separate components. It is a form of parasite drag.

interferometer, noun. An optical device that splits a beam of light into two parts and utilizes the interference between the two resulting beams for the measurement of wave lengths, used in aerodynamics to portray and photograph the density variations in a field of flow. One of the two beams of light travels through free space, the other travels through the field of flow about the test object; the two beams, arriving at the screen out of phase (the beam that travels through the flow field being variable), show by distortion of the interference pattern the density variations in the field of flow.

interior ballistics. That branch of ballistics that deals with the propulsion of projectiles, i. e., the motion and behavior of projectiles in a gun barrel, the temperatures and pressures developed inside a gun barrel or rocket, etc.

intermediate field. Any one of many emergency airfields or landing strips maintained by the Government at established intervals along the airways.

intermesh, verb intr. Of rotor blades in a dual rotor arrangement: To rotate in a synchronized fashion such that the blades of each rotor do not strike one another, though the rotor disks intersect.

intermittent-jet engine. Same as **PULSE-JET ENGINE**.

intermittent pressure breathing. Pressure breathing in which different pressures are used at different points in the respiratory cycle, usually with a high pressure during inspiration and a lower pressure during expiration. See **PRESSURE BREATHING**.

intermittent wind tunnel. A wind tunnel through which the air passes in a blast of relatively brief duration.

See **BLOWDOWN WIND TUNNEL**, **INDRAFT WIND TUNNEL**, **SHOCK TUBE**.

internal balance. A device used for aerodynamic balance of a control surface, consisting of an overhang extending forward of the hinge line into a chamber in the fixed airfoil, the chamber being vented to the open in such a way as to bring balancing air forces to bear on the overhang. See **SEALED INTERNAL BALANCE**.

internal-combustion engine. An engine in which the working substance or pressure necessary to move the engine or its parts is derived from the combustion of fuel within a chamber or chambers that are an integral part of the engine. Types of internal-combustion engines include reciprocating engines where the fuel is burned within the cylinders of the engine, rocket engines, and the various types of jet engines.

internal efficiency. The efficiency with which a reaction engine, such as a rocket, converts the available thermal energy of its combustion gases into kinetic energy in the exhaust jet, expressed as a ratio.

internal supercharger. A gear-driven supercharger built as an integral part of the engine, which compresses the fuel-air mixture or the air and delivers it directly to the cylinders. Cf. **EXTERNAL SUPERCHARGER** and see **GEAR-DRIVEN SUPERCHARGER**.

interphone, noun. A telephone, microphone, receiver, or a combination microphone-receiver by means of which communication is carried out between different stations in an aircraft, between offices of the same organization, etc.; an **INTERCOM**.

interplane aileron. A kind of external aileron, now obsolete, mounted between the wings of a biplane or other multiplane.

interplane strut. A strut between two wings or other surfaces.

See **I-STRUT**, **N-STRUTS**, **V-STRUTS**.

interrogation, noun. *Radar.* The act of sending forth radar pulses to trigger a transponder to receive answering signals; the radar pulses so sent. Also called a "challenge."

interrogator, noun. A radar set or other electronic device that transmits an interrogation (which see).

interrogator-responder, noun. An electronic device combining an interrogator and a receiver for receiving and displaying the answering signals of a transponder.

interrupter gear. Specif., a SYNCHRONIZING GEAR.

intervalometer, noun. Any device that may be set so as to accomplish automatically a series of like actions, such as the taking of aerial photographs, at constant predetermined intervals.

inverse taper. Taper of a wing or other surface such that the chord length decreases from tip to root.

inversion, noun. *Meteorol.* A TEMPERATURE INVERSION.

inverted engine. An in-line engine having the cylinders below the crankshaft.

inverted flight. Flight with the aircraft upside down.

inverted gull wing. A gull wing having its inboard section at a negative dihedral.

inverted loop. A loop (inside or outside, half or full) begun from, and, when a full loop, ending in, inverted flight.

inverted spin. A spin in which the airplane is upside down throughout.

inverter, noun. A device for converting direct current into alternating current, often used in aircraft electrical systems.

inviscid, adj. Not viscous, not clinging or sticky; frictionless, as in *inviscid* flow.

ionosphere, noun. A region of the atmosphere characterized by ionized

gases, generally considered to extend from a height of about 50 miles (but sometimes 25 or 30 miles) above the earth's surface to a height of 250 miles or more. The ionosphere includes layers of highly ionized air. See D-LAYER, E-LAYER and F-LAYER.

iris-type nozzle. A jet exhaust nozzle having a circular exit orifice of variable diameter.

irreversible control system. An aircraft control system designed so that aerodynamic forces acting on the control surfaces are not transmitted back to the pilot's controls.

irrotational flow. Flow in which the individual small elements of the fluid do not rotate about their own axes.

isobaric surface. An atmospheric surface at which the pressure is the same throughout.

iso-octane, noun. Specif., a particular isomer of octane (2,2,4-trimethylpentane) having a high antiknock value as a fuel. Sometimes called "octane" (which see).

isotach, noun. A line on a chart connecting points of equal speed value, commonly used for wind speed.

isothermal layer. A layer or region of the atmosphere considered to have uniform temperature throughout. This layer, conterminous with the stratosphere, varies in thickness, but its lower limit generally occurs at about 35,000 feet. Also called the isothermal region.

I-strut, noun. A strut, usually an interplane strut, in the shape of the letter "I."

J

jacket, noun. A covering or casing of some kind; specif.: a. A shell around the combustion chamber of a rocket, through which the propellant is circulated in regenerative cooling. See REGENERATIVE COOLING. b. The cooling jacket of a piston engine.

jamming, noun. Specif., the action of making electronic apparatus or their transmissions ineffective or unintelligible with interfering transmissions or reflections.

JATO, Jato, or jato, noun. [From "jet-assisted take-off."] 1. a take-off utilizing an auxiliary jet-producing

unit or units, usually rockets, for additional thrust. Hence, JATO bottle, Jato unit, etc., a rocket or unit so used. Where rockets are the auxiliary units, "RATO" (which see) is the more specific term. 2. A JATO bottle or unit; the complete auxiliary power system used for assisted take-off.

jet, noun. 1. A strong, well-defined stream of fluid either issuing from an orifice or moving in a contracted duct, such as the *jet* of combustion gases issuing from a reaction engine, or the *jet* in the test section of a wind tunnel. See FREE JET. 2. A tube, nozzle, or the

like through which fluid passes, or from which it issues, in a jet, such as a *jet* in a carburetor. See METERING JET, PRESSURE JET. 3. A jet engine, as, an airplane with *jets* slung in pods. 4. A jet airplane, as, the long runways needed for *jets*.

jet aircraft. Aircraft, or an aircraft (usually a fixed-wing airplane), powered by one or more air-breathing jet engines.

jet airstream. A stream of air moving in a jet; a JET STREAM (in sense 1).

jet-assisted take-off. The full term for "JATO" (in sense 1, which see).

jet engine. 1. Broadly, any engine that ejects a jet or stream of gas or fluid, obtaining all or most of its thrust by reaction to the ejection. *Rare.* See REACTION ENGINE. 2. Specif., an aircraft engine that derives all or most of its thrust by reaction to its ejection of combustion products (or heated air) in a jet and that obtains oxygen from the atmosphere for the combustion of its fuel (or outside air for heating, as in the case of the nuclear jet engine)—disting. in this sense from a rocket engine. A jet engine of this kind may have a compressor, commonly turbine-driven, to take in and compress air (*turbojet*), or it may be compressorless, taking in and compressing air by other means (*pulsejet*, *ramjet*). (See individual entries on these types.) See also CAMPINI ENGINE, GAS-TURBINE ENGINE.

jet exhaust. A jet of exhaust gases, esp. from a jet engine.

jet flap. A sheetlike jet of air ejected downward from a thin spanwise slot near the trailing edge of a wing, whose action is similar to that of an ordinary airfoil-type flap.

jet helicopter. A helicopter having a jet rotor or a jet-engine power plant.

jet lift. An upward force acting on an aircraft from one or more vertical jets.

jet nozzle. A nozzle, usually specially shaped, for producing a jet, such as the exhaust nozzle on a jet or rocket engine. See ROCKET NOZZLE.

jet-propelled, adj. 1. Propelled by one or more air-breathing jet engines, as in *jet-propelled* airplane. 2. Propelled by a jet or jets, either from jet or rocket engines. *Rare.* See ROCKET-PROPELLED.

jet propulsion. Propulsion by means of a jet (in sense 1, which see) or jets;

specif., propulsion by one or more air-breathing jet engines. See REACTION PROPULSION.

jet-propulsion engine. Same as JET ENGINE (in sense 1 or sense 2).

jet rotor. A rotor driven by jet devices of one kind or another mounted within or upon the rotor blades, usually at the tips. The driving units may be pulsejets, ramjets, compressed-air jets, etc. See PRESSURE JET.

jet stack. An exhaust stack on reciprocating engines directed rearwardly so as to obtain thrust from the ejected gases. See EXHAUST STACK.

jet stream. 1. A strong, narrow band of wind or winds in the upper troposphere or in the stratosphere, moving in a general direction from west to east and often reaching velocities of hundreds of miles an hour. 2. A stream moving in a jet, such as the stream of combustion products issuing from a reaction engine. See JET, sense 1.

jet thrust. The thrust of a fluid jet, esp. as disting. from the thrust of a propeller.

The thrust of a rocket engine is calculated in the same manner as gross thrust of a jet engine. See GROSS THRUST, note.

jettison, verb tr. To throw or dump overboard, drop, or eject (tanks, fuel, gear, etc.) from an aircraft in order to disencumber it, as for emergency action.

jettisonable, adj. Capable of being jettisoned.

jet vane. A vane, either fixed or movable, used in a jet stream, esp. in the jet stream of a rocket, for purposes of stability or control under conditions where external aerodynamic controls are ineffective. Cf. AIR VANE.

jet velocity. The velocity of a jet, measured, e. g., with respect to the jet nozzle.

Joule cycle. [After James Prescott Joule (1818-1889), English physicist.] An ideal cycle for internal-combustion engines consisting of isentropic compression of the working substance, addition of heat at constant pressure, isentropic expansion to ambient pressure, and exhaust at constant pressure. Also called "Brayton cycle."

joy stick. The control stick of a fixed-wing airplane. *Slang.* See CONTROL STICK.

jump, noun. A PARACHUTE JUMP.

jump, verb. 1. *intr.* To make or perform a parachute jump. 2. *tr.* To let (parachute troops) jump from an aircraft, as, to *jump* paratroops from both sides of an aircraft.

jumper, noun. A parachutist, i. e., one who makes parachute jumps in the routine of his occupation.

jump take-off. With a rotary-wing aircraft, a type of take-off in which the

rotor blades, at a non-lifting pitch, are driven at a high rpm, then suddenly increased in pitch, resulting in a take-off at a comparatively high initial speed. With an autogiro, power is disengaged from the rotor after take-off.

jury strut. An auxiliary strut that braces a main strut or struts, used, e. g., between a main strut and a wing, or between two main struts.

K

Kármán vortex street. [After Theodore von Kármán (1881-), Hungarian-born American scientist.] A double trail of vortices formed alternately on both sides of a cylinder or similar body moving at right angles to its axis through a fluid, the vortices in one row rotating in a direction opposite to that of the other row.

K class. A class of Goodyear airships having a volume of 456,000 cubic feet.

keel, noun. 1. A longitudinal member or ridge along the center bottom of a seaplane float or hull; also, the longitudinal center bottom of an airplane fuselage, or a main structural member running along the center bottom. 2. A middle longitudinal member or structure at the bottom of a rigid or semi-rigid airship, designed to prevent hogging or sagging and to distribute loads.

keelson, noun. A very rigid and strong internal member in a float or hull giving shape to the keel ridge, or supporting the keel.

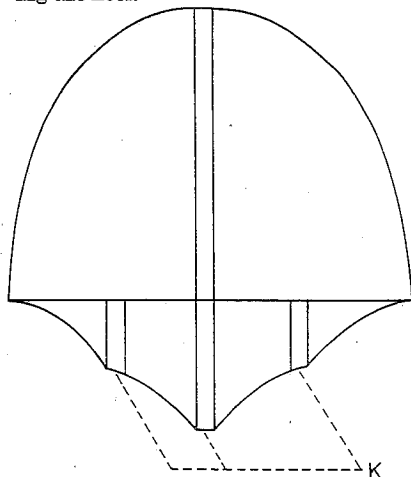

Transverse section of float showing center and side keelsons K.

kickback, noun. A reversal of engine rotation during starting, caused by highly advanced timing or by preignition.

kinematic viscosity. A term applied to the ratio of fluid viscosity to fluid density, indicative of accelerations of the fluid arising from a given distortion.

kite, noun. An airborne device consisting essentially of a light, thin surface or structure, or of an assembly of such surfaces, usually of paper or cloth stretched over a light wooden framework, sustained by the wind and restrained and held at a suitable angle of attack by a towline. The kite is usually regarded as a kind of aircraft.

kite balloon. An elongated captive balloon having one or more air-filled lobes or stabilizers serving as an empennage to head the balloon into the wind, and rigged so as to keep its long axis inclined to the wind, deriving aerodynamic lift, in the fashion of a kite, in addition to aerostatic lift. Some earlier types of kite balloon were fitted with a stabilizing tail. See DRACHEN, KYTOON.

knock, noun. The noise associated with detonation or explosion of the fuel-air mixture in an internal-combustion piston engine. See DETONATION, sense 2 and note.

knot, noun. One nautical mile (6076.1033 feet) per hour.

Kollsman number. A number representing an altimeter setting. See ALTIMETER SETTING.

kytoon, noun. [Coined from "kite balloon."] A type of small captive balloon, similar to the ordinary kite balloon and deriving lift in the same fashion, but with an empennage consisting of thin plane surfaces rather than the air-filled fabric lobes of the kite balloon.

L

labyrinth, noun. A kind of seal or gland consisting of baffles, grooves, rings, etc. in an intricate arrangement designed to restrict a flow or to minimize leakage, as behind the rotary element of a compressor.

lag, noun. 1. A hesitation or delay, as: a. The delay in an instrument or instrument system in indicating a change. b. CONTROL LAG. c. IGNITION LAG. 2. The action of lagging.

lag, verb intr. Of an articulated rotor blade: To trail behind or to advance ahead of the position defined by a line drawn through the center of rotation and the drag hinge.

lag angle. With a rotary-wing aircraft, the angle between the span axis of a rotor blade and a line through the center of rotation and the drag hinge. This angle is considered positive when the blade is trailing. Also called a "drag angle." See LEAD ANGLE.

lag hinge. Same as DRAG HINGE.

lamina, noun. 1. A layer of fluid. See LAMINAR FLOW. 2. Meteorol. A stratum of the atmosphere between specified altitudes.

laminar flow. A smooth flow in which no cross flow of fluid particles occurs, hence a flow conceived as made up of layers—commonly disting. from TURBULENT FLOW.

laminar-flow airfoil. An airfoil specially designed to maintain extensive laminar flow over its surface.

laminar separation. The separation of a laminar-flow boundary layer from a body.

laminar sublayer. A very thin layer of laminar flow in a boundary layer, next to the body and beneath a turbulent layer.

land, verb. 1. *intr.* a. To come down to earth (land or water) or other firm surface (as a carrier deck), and, usually, there to come to rest—said of aircraft or of persons within, as, a plane that *lands*, then rolls to a stop, or, a pilot who *lands* and alights from his airplane. b. Of an airship: To alight on the surface as indicated in sense 1a, or to come down near to the surface for mooring or docking—also of persons within. 2. *intr.* To alight upon or to hit the earth's surface (land

or water)—said of a parachutist, of a rocket, etc. 3. *tr.* To bring (an aircraft) down to the surface. 4. *tr.* To bring (passengers, cargo, etc.) down to earth in an aircraft and discharge the load, as, to *land* troops.

land airplane. A LANDPLANE.

landfall, noun. 1. The sighting of land from seaward; also, by extension, the contacting of land by other than visual means, as by radar, after a water crossing. 2. A navigational procedure in which an aircraft, in a passage over water, turns onto a line of position going through its destination and follows the line of position to destination.

landing, noun. 1. The action of the verb *land*, or an instance of accomplishing this action. 2. The entire action of descending to the surface in an aircraft (including flying the approaches), making contact, and, usually, completing the landing run or coming to rest.

Sense 2 may sometimes be arbitrarily defined to include the entire operation following descent to some specified altitude.

landing angle. The acute angle between a specified or understood wing chord of an airplane and the horizontal at the instant of touchdown with the airplane in its normal landing attitude.

landing approach. An APPROACH (esp. in sense 1).

landing area. That part of an airdrome or airport or any other land or water area, such as an airstrip, for the landing and take-off of aircraft; also, that area of a carrier deck for the landing of airplanes.

landing beam. A radio beam establishing the glide slope in an instrument landing system. See GLIDE PATH, sense 2.

landing brake. A device using aerodynamic reactions to slow down an aircraft in landing, such as a reversible-pitch propeller. See AIR BRAKE.

landing crew. A crew on the ground that assists in docking or mooring an airship, or in handling it on the ground. Sometimes called a "ground crew" (which see).

landing deck. The flight deck of an aircraft carrier. See FLIGHT DECK, sense 2.

landing distance. The distance that an airplane covers in its landing run.

landing field. A clear or cleared land area for the landing and take-off of aircraft; that part of an airfield or of an airship station where aircraft land and take off.

landing flap. A flap—so called when considering its special application in landing. See *FLAP*, *noun*, sense 1.

landing flare. 1. A pyrotechnic flare sometimes dropped from an aircraft for illumination during a night landing. See *FLARE*, *noun*, sense 1. 2. A *FLARE-OUT*.

landing gear. 1. The apparatus comprising those components of an aircraft that support and provide mobility for the aircraft on land, water, or other surface. The landing gear consists of wheels, floats, skis, bogies and treads, or other devices, together with all associated struts, bracing, shock absorbers, etc. "Landing gear" includes all supporting components, such as the tail wheel or tail skid, outrigger wheels or pontoons, etc., but the term is often conceived to apply only to the principal components, i. e., to the main wheels, floats, etc., and the nose gear, if any. See *AUXILIARY LANDING GEAR*. 2. Either of the main wheels or units of a wheel-type landing gear when such a landing gear is so disposed that the major units can be regarded independently, as, the left *landing gear*. 3. *Rocketry*. A parachute and release mechanism used in lowering a rocket to earth.

See *BICYCLE LANDING GEAR*, *CROSS-WIND LANDING GEAR*, *FIXED LANDING GEAR*, *NOSE GEAR*, *QUADRICYCLE LANDING GEAR*, *RETRACTABLE LANDING GEAR*, *TANDEM LANDING GEAR*, *TRACK-TYPE LANDING GEAR*, *TRICYCLE LANDING GEAR*.

landing-gear indicator, or landing-gear position indicator. An indicator that shows if the landing gear is extended or retracted.

landing light. A light, usually one of two or more, mounted on an aircraft and used to illuminate the surface during landing.

landing mat. A mat, usually of metal mesh or pierced metal strips, laid down as a runway.

landing pattern. Same as *APPROACH PATTERN*.

landing roll. The landing run of an aircraft with a wheeled or track-type landing gear. See *LANDING RUN*.

landing run. The movement or travel of an aircraft on the land, water, or other surface under the impetus of its landing speed after touchdown.

landing skid. A skid or runner used in the main landing gear of an airplane, upon which the airplane slides over the ground.

landing speed. 1. The minimum speed at which an airplane may touch down under control. 2. The speed of an airplane at touchdown in a normal landing. 3. The speed of an airplane at touchdown.

landing strip. 1. Any long and narrow area, usually paved, forming a part of a landplane airport or airfield, for the take-off and landing of airplanes; a runway. 2. An *AIRSTRIPE*.

landing T, or, landing tee. Same as *WIND TEE*.

landing wire. A wire or cable that braces a wing against forces opposite in direction to the direction of lift, as occur, e. g., in landing. Also called an "antilift wire." Cf. *FLYING WIRE*.

landmark, noun. A distinctive object, feature, or place on the ground, such as a mountain, river bend, or city, used to ascertain the position of an aircraft or to aid in flying a course.

landmark beacon. A light beacon, other than an airport or airway beacon, that marks a specific geographical location.

landplane, noun. An airplane designed for taking off and alighting on land or other firm surface—disting. esp. from a seaplane. Landplanes include carrier planes, and by definition, ski-planes also, although the term usually signifies an airplane with a wheeled or track-type landing gear.

lap belt. A safety belt that fastens across the lap. This is the usual kind of safety belt. Also called a "seat belt."

lapse rate. *Meteorol.* The rate of change of temperature, pressure, or some other meteorological phenomenon with altitude, usually the rate of decrease of temperature with increasing height.

lateral, adj. 1. Of or pertaining to the side; directed or moving toward the side. 2. Of or pertaining to the lateral axis; directed, moving, or located along, or parallel to, the lateral axis.

lateral acceleration. Acceleration substantially along the lateral axis of an aircraft, rocket, etc.

lateral attitude. The attitude of an aircraft, rocket, etc. with respect to the normal position of its lateral axis.

lateral axis. An axis going from side to side of an aircraft, rocket missile, etc., usually the side-to-side body axis passing through the center of gravity. Sometimes called a "transverse axis." See *AXIS*, sense 2 and note, *PITCH AXIS*.

lateral control. Control over the rolling movement of an aircraft, rocket, etc., or over lateral attitude. With a fixed-wing airplane, this control is usually accomplished by the use of ailerons.

lateral oscillation. A rolling, yawing, or sideslipping oscillation, or any combination of these oscillations.

The Dutch roll is a complex lateral oscillation.

lateral separation. In air traffic control, the separation of aircraft from side to side.

lateral stability. The tendency of a body, such as an aircraft, to resist rolling, or, sometimes also, to resist lateral displacement; the tendency of an aircraft to keep its wings level, either in flight or at rest.

lattice, noun. 1. A pattern or network of intersecting lines, such as a network of lines of position established by radio-directive devices. 2. An assembly of intersecting slats, bars, or the like; a grid; also, a row of parallel vanes or airfoils. See *CASCADE*, sense 1.

launch, verb tr. To release or send forth; to send forth by launcher; also, to catapult.

launcher, noun. 1. Specif., a structure or device, often incorporating a tube, a group of tubes, or a set of tracks, from which self-propelled missiles are sent forth and by means of which the missiles usually are aimed or imparted initial guidance—disting. in this specific sense from a *CATAPULT*. 2. Broadly, a structure, machine, or device, including the catapult, by means of which airplanes, self-propelled missiles, or the like are directed or hurled or sent forth.

launching angle. The angle between a horizontal plane and the longitudinal axis of a rocket, etc. being launched.

launching rack. A skeletonlike structure, usually incorporating rails, from which something is launched.

Laval nozzle. Same as *DE LAVAL NOZZLE*.

lazy eight. A kind of eight (which see) in which the airplane turns, dives, and climbs such that in the vertical plane the resulting flight path resembles a figure eight lying on its side and in the horizontal plane resembles the letter "S."

L class. A class of Goodyear airships having a volume of 123,000 cubic feet.

lead angle. A negative lag angle. See *LAG ANGLE*.

leading edge. The forward edge of an airfoil, blade, etc., i. e., the edge which normally meets the air or fluid first. See *SUPERSONIC LEADING EDGE* and cf. *TRAILING EDGE*.

leading-edge angle. The angle between the upper and lower surfaces near the leading edge of an airfoil, esp. an airfoil with a sharp leading edge and non-curved surfaces.

leading-edge flap. A flap installed at the leading edge of a wing. It may be a split flap, extensible flap, or other kind of flap. See *DROOP FLAP*.

leading-edge radius. The radius of a circle whose arc coincides with the leading edge of an airfoil profile.

lean, adj. Of a combustible mixture: Having a relatively low proportion of fuel to air or oxidant; more precisely, having a value less than stoichiometric.

lean blowout. A blowout (which see) caused by a too-lean fuel-air mixture.

left, noun. 1. Specif., the left side of an aircraft. See *LEFT*, *adj.* 2. The area or direction to one's left-hand side, as, to turn to the *left*.

See *PORT*, *noun*, sense 1.

left, adj. Specif., situated on, or directed toward, the left-hand side of a person at the longitudinal axis of an aircraft and facing forward, as in *left bank*, *left wing*; coming from the left, as in *left wind*. See *PORT*, *adj.*

left-hand engine. An engine whose crankshaft or other main shaft rotates in a counterclockwise direction, as seen from the antipropeller end of the engine.

With a turbojet engine, e. g., the direction of view is from the exhaust end.

leg, noun. 1. A distinct segment, as between landings, of an air journey, as, the *leg* between Seattle and Anchorage. 2. One of the straight-line segments of a pattern flown in the air, as, a cross-wind *leg*. 3. A landing-gear strut,

when the landing wheel is supported by a single strut.

length, noun. Specif., the dimension of an aircraft, rocket, etc. from nose to tail; the measure of this dimension. Cf. SPAN.

The length of an airplane, etc., takes in the extremities, such as propeller, antenna, and tail surfaces. It is sometimes called "over-all length."

length-beam ratio. The ratio of the length of a seaplane float or hull to its beam. Cf. FINENESS RATIO.

let, verb intr. To let down. To descend in a glide, usually a shallow glide, esp. preparatory to making an approach or landing.

letdown, noun. An act or instance of letting down, esp. the gliding descent of an aircraft from cruising altitude prior to an approach or landing.

level, noun. A horizontal line, plane, or region at a given height, as, a level at which icing conditions prevail.

level, verb intr. To level off or out. To enter horizontal flight after a climb, dive, or glide.

The tendency is to say, "to level off" from a climb, and "to level out" of a dive or glide.

lift, noun. 1. That component of the total aerodynamic force acting on a body perpendicular to the direction of the undisturbed airflow relative to the body. This lift, sometimes called "aerodynamic lift," acts on any body or system of bodies such as an airfoil, a fuselage, an airplane, an airship, a rotor, etc., at a suitable angle of attack in the airflow.

Lift is usually thought of as a force acting in an upward direction, giving sustentation to aircraft. By definition, however, lift can, and does, act in any direction: downward, as with a horizontal tail when required for longitudinal trim; sideward, as with a vertical tail when an aircraft is turned. When lift in a direction other than upward is under discussion, it may be specified in the expressions "negative (downward) lift," or "horizontal lift," although the latter expression is usually avoided.

This phenomenon of aerodynamic lift is explained by either or both of two laws or theorems: (1) By Newton's third law of motion, in which a body, deflecting air in one direction, obtains a force upon itself acting in the other direction. (2) By Bernoulli's law, in which an increase of air velocity over the body gives a pressure decrease resulting in lift. See BERNOULLI'S LAW.

2. The upward force or buoyancy exerted on a balloon or airship by the air it displaces. See AEROSTATIC LIFT. 3. An upward-acting force. See JET LIFT.

lift coefficient. A coefficient representing the lift of a given airfoil or other body.

The lift coefficient is obtained by dividing the lift by the free-stream dynamic pressure and by the representative area under consideration.

lift component, or lift force. The component of the total dynamic forces on a body in a fluid flow, acting in the lift direction.

lift direction. The direction in which lift acts on a body. The lift direction is perpendicular to the relative wind, and parallel or perpendicular to some other chosen reference, depending upon the body under consideration; with a wing, e. g., the direction is parallel to the plane of symmetry.

lift distribution. The spanwise disposition of the lift along a wing or other lifting surface.

lift-drag ratio. The ratio of lift to drag, obtained by dividing the lift by the drag, or the lift coefficient by the drag coefficient.

lifting gas. Any lighter-than-air gas for a balloon or airship.

lifting line. In aerodynamic theory, a spanwise line through an airfoil, identified with a bound vortex, along which the lift is assumed to be concentrated. See BOUND VORTEX.

lift-off jump. A parachute jump in which the jumper deploys his parachute from the aircraft and allows it to drag him off.

lift strut. A wing strut designed as an airfoil so that, in addition to serving as a brace, it contributes to the lift of the airplane.

lift web. Any one of the fabric straps connecting a parachute harness to the shroud lines. Sometimes called a "riser" (which see).

lift wire. Same as FLYING WIRE.

light beacon. A light, or a number of lights grouped together, set up as a beacon to aid in navigation.

See AIRPORT BEACON, AIRWAY BEACON, CODE BEACON, FLASHING BEACON, LANDMARK BEACON, ROTATING BEACON.

lighter-than-air, adj. 1. Of aircraft: That can be inflated so as to weigh less than the displaced air and so be lifted aerostatically. See LIGHTER-THAN-AIR AIRCRAFT, note. 2. Of, pertaining to, or dealing with, lighter-than-air aircraft, as in *lighter-than-air* activity, *lighter-than-air* pilot.

This term is hyphenated only as an attributive adjective.

lighter-than-air aircraft. Aircraft, or an aircraft, that can rise and remain suspended in the air by virtue of contained air or gas weighing less than the displaced air. A lighter-than-air aircraft is also called an "aerostat."

Dirigibles (as well as kite balloons) derive a measure of lift aerodynamically when flown at a proper angle of attack, and for this reason dirigibles may be flown actually somewhat heavier than air. See HEAVIER-THAN-AIR AIRCRAFT, note.

light gun. A spotlight with which differently colored light signals are flashed, used in traffic control at an airport.

lightplane, noun. Also light plane. A lightly constructed, lightweight airplane.

limit load. The maximum load which it is calculated that an aircraft member or part will experience in service.

limit stop. An abutment or other device that limits the movement of something, used, e. g., in a flexible machine-gun mounting on an aircraft to prevent gunfire from hitting a part of the aircraft, in a gyroscopic instrument to prevent excessive damaging angular movement, etc. Sometimes popularly called a "check stop." See DRAG STOP, DROOP STOP.

line, noun. An airline, control line, flight line, etc.

linear acceleration. Acceleration along a line or axis.

linear array. An antenna arrangement having its elements assembled in a straight line.

linear twist. A twist of an airfoil such that the angle of attack at any section is directly proportional to the spanwise distance from a specified reference line or plane.

line of flight. The line in air or space along which an aircraft, missile, etc., flies or travels.

line of position. In air navigation, a line along which an aircraft is known to be, i. e., a line containing all possible locations of an aircraft at a given instant. A line of position may be a circle of equal altitude, a radio bearing, a line in the direction of a bearing, etc. A railroad, highway, or the like may also provide a line of position.

line of sight. 1. The straight line between the eye of an observer and the observed object or point. 2. Any

straight line between one point and another, or extending out from a particular point.

liner, noun. Specif., an INNER LINER.

Link trainer. [After *Link Aviation, Inc.*] A simulator (which see) for training in certain skills or techniques, esp. instrument flying.

liquid-cooled, adj. Cooled by liquid, such as water or alcohol, as in *liquid-cooled* engine.

liquid propellant. Specif., a rocket propellant in liquid form. See ROCKET PROPELLANT.

Examples of liquid propellants include fuels such as alcohol, gasoline, aniline, liquid ammonia, and liquid hydrogen; oxidants such as liquid oxygen, hydrogen peroxide (also applicable as a monopropellant), and nitric acid; additives such as water; and monopropellants such as nitromethane.

liquid-propellant rocket engine or motor. A rocket engine or motor using a propellant or propellants in liquid form. Rocket engines of this kind vary somewhat in complexity, but they consist essentially of one or more combustion chambers together with the necessary pipes, valves, pumps, injectors, etc. See LIQUID PROPELLANT and ROCKET ENGINE.

load, noun. 1. That which is put, or intended to be put, aboard an aircraft; the amount of this burden. 2. *Engineering.* A stress-producing force, or the resultant of a system of stress-producing forces, imposed upon an aircraft, aircraft component, or other body; the value of such a load. See LOADING.

In sense 1, see PAYLOAD, USEFUL LOAD; in sense 2, see AERODYNAMIC LOAD, ALLOWABLE LOAD, AXIAL LOAD, BASIC LOAD, DESIGN LOAD, DYNAMIC LOAD, FULL LOAD, GUST LOAD, IMPACT LOAD, LIMIT LOAD, MANEUVERING LOAD, STATIC LOAD, ULTIMATE LOAD, YIELD LOAD.

load adjuster. A special slide rule used in weight and balance calculations of the load placed aboard an aircraft.

load face. Same as BLADE FACE.

load factor. 1. *Engineering.* A factor representing the ratio of some specified load (such as a maneuvering load, the design load, or the ultimate load) to a basic load. If the context does not indicate what load is being compared with the basic load, usually the design load is meant. 2. In air transport, a factor representing the ratio of the actual load carried to the maximum load that could be carried.

loading, noun. Engineering. 1. A load (in sense 2), as, a heavy *loading*. 2. Loads collectively, as, a distribution of *loading*; the application of a load, or of loads, as, repeated *loading*—often in these senses with the suggestion of continuing application or exertion.

See BLADE LOADING, DISK LOADING, SPAN LOADING, UNSYMMETRICAL LOADING, WING LOADING.

3. The ratio of the weight of a vehicle to its power, i. e., POWER LOADING or THRUST LOADING.

load ring. A concentration ring on a free balloon. See CONCENTRATION RING.

load water line. A line on a seaplane float or hull indicating the depth to which the float or hull sinks under a normal load.

lobe switching. The periodic directing of lobe-shaped radio-frequency beams between different positions in scanning or direction finding.

localizer, noun. A radio beacon used in an instrument landing system to give lateral guidance along the final approach. The localizer transmits two signal patterns overlapping along the center line of the runway and along the projection of the center line from both ends of the runway. Sometimes called a "runway localizer."

local velocity. The velocity at some localized point in a field of flow. Cf. REMOTE VELOCITY.

location marker. Any of several kinds of radio beacons located along an airway or in an instrument landing system, transmitting a characteristic signal to provide position or distance information to aircraft. Often called a "radio marker." See FAN MARKER, Z MARKER.

loft, noun. 1. A building, room, or place where lofting is done. 2. A PARACHUTE LOFT.

lofting, noun. The making or piecing together of full-sized drawings of a body or configuration, as of an airplane hull or fuselage or of a wing-fuselage intersection, so as to minimize error in determining dimensions and interference of components and in making patterns.

log, noun. 1. A record or history, as: a. A record of a flight by an aircraft, containing information such as that concerning the course or courses flown, speed, positions, important occurrences

aboard the aircraft, observations, etc. See FLIGHT LOG, sense 1. b. A history of a particular piece of equipment, as of an engine. See PARACHUTE LOG. c. A record of a person's flying hours, including kind of flying performed. 2. Any of certain instruments or devices that measure, indicate, or record data about the flight of an aircraft, a rocket missile, etc. See AIR LOG, FLIGHT LOG, sense 2.

longeron, noun. A principal longitudinal member in a fuselage, nacelle, or the like, heavier than a stringer (which see). Cf. SPAR.

longitudinal, adj. 1. Directed, moving, or placed lengthwise; of or pertaining to the lengthwise dimension. 2. Of or pertaining to the longitudinal axis.

longitudinal acceleration. Acceleration substantially along the longitudinal axis of an aircraft, rocket, etc.

longitudinal axis. An axis going from nose to tail of an aircraft, rocket, etc., usually a fore-and-aft body axis passing through the center of gravity. See AXIS, sense 2 and note, ROLL AXIS.

longitudinal control. Control over the pitching movement of an aircraft, rocket, etc.

longitudinal decalage. The decalage (which see) of two surfaces mounted in tandem.

longitudinal oscillation. 1. The oscillation of an aircraft or other flying body in its plane of symmetry, consisting of pitching, climbing, and diving motions. See PHUGOID OSCILLATION. 2. In *Rocketry*. Pressure oscillation in a combustion chamber along the longitudinal axis.

longitudinal separation. In air traffic control, the separation between aircraft along a longitudinal line.

longitudinal stability. The stability of an aircraft with respect to pitching motions, or, sometimes also, with respect to vertical displacement and fore-and-aft motion.

loop, noun. 1. An airplane maneuver in which the airplane makes an approximately circular flight path in the vertical plane, its lateral axis remaining horizontal and perpendicular to the flight path; specif., a NORMAL LOOP. 2. The approximately circular flight path flown in this maneuver.

See HALF-LOOP, INSIDE LOOP, INVERTED LOOP, OUTSIDE LOOP.

3. A GROUND LOOP or WATER LOOP. 4. A RAIN LOOP.

loop, verb. 1. *tr.* To put into a loop. 2. *intr.* To make a loop. 3. *To loop the loop.* To make a loop. *Popular.*

The phraseology of sense 3 derives from a circus stunt in which the performer rides a car that is made to coast over an upright circular track; hence, the performer "loops the loop."

loop antenna. A directional antenna in the form of a closed loop, rectangle, or other shape.

The loop antenna radiates or receives at a maximum intensity in or from a direction parallel to the plane of the loop. See AURAL NULL.

loop-the-loop, noun. [See LOOP, verb, note.] A normal loop. *Popular.* See LOOP, noun, sense 1.

loop-type radio range. A type of radio range employing two loop antennas placed at right angles to one another. One antenna sends out the Morse letter "A" and the other sends out the letter "N," producing a radiation pattern resembling in a graphic representation two figure eights crossing one another, containing four overlapping zones or quadrants, with alternating "A" and "N" zones. The dots and dashes of the "A" and "N" signals merge into a steady hum along lines bisecting the overlapping portions of the zones, producing four courses or beams centered at the antennas for the guidance of aircraft.

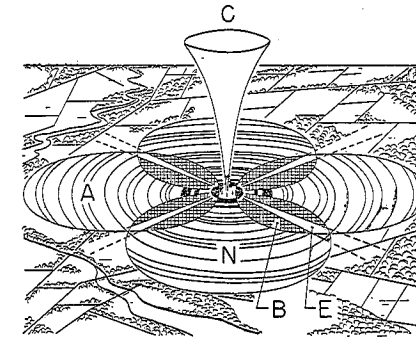

Radio range, loop-type or Adcock. A, N radiation patterns of Morse A and N signals; B bi-signal zone; E equisignal zone; C cone of silence.

LOP—Abbreviation for *line of position*—pronounced by letter.

loran, noun. [From "long-range navigation"; sometimes capitalized.] A particular kind of long-range navigation system in which hyperbolic lines of position are established by the time difference in the arrival of radio signals from ground stations. See HYPERBOLIC NAVIGATION.

low-altitude, adj. 1. Performed or conducted at an altitude considered relatively low, as in *low-altitude navigation*. 2. Designed for operation or use at a low altitude, as in *low-altitude fighter*. 3. Established or occurring at a low altitude, as in *low-altitude route*, *low-altitude turbulence*.

low-drag, adj. Specially designed to produce little drag, as in *low-drag cowling*, *low-drag fuselage*, *low-drag wing*.

lower camber. The camber of the underside of an airfoil. Sometimes called "bottom camber."

low pitch. The pitch of a propeller or propeller blade at a small blade angle.

low-pressure chamber. A chamber in which a low pressure prevails; a DECOMPRESSION CHAMBER.

low-wing monoplane. A monoplane whose wing or wing halves are mounted at or near the bottom of the fuselage.

lox, or loxygen, noun. Liquid oxygen.

lubber line, or, less frequently, lubber's line. 1. A line on any direction-indicating instrument or device, such as a compass or directional gyro, representing the longitudinal axis of the aircraft or vessel, and hence indicating heading. 2. Loosely, a reference line on any instrument, such as a horizontal line on an attitude gyro.

lufbery, noun, or lufbery circle. [After Raoul G. Lufbery (1885-1918), WW I aviator.] A military airplane maneuver or formation in which two or more airplanes follow one another in a spiral or in an approximately horizontal circle, offering mutual protection and defense against attacking planes; also, any formation or flight configuration in which planes follow one another in a circle or spiral.

—*lufbery, verb intr.* To fly in a lufbery circle.

M

M. A. C.—Abbreviation for *mean aerodynamic chord*.

Mach. See MACH NUMBER.

Mach angle. The angle between a Mach line and the direction of movement or undisturbed flow.

Mach cone. 1. The cone-shaped shock-wave theoretically emanating from an infinitesimally small particle moving at supersonic speed through a fluid medium. It is the locus of the Mach lines. See MACH LINE. 2. The cone-shaped shock wave generated by a sharp-pointed body, as at the nose of a high-speed aircraft.

Mach indicator. Same as MACHMETER.

machine, noun. A contrivance of some sort; in aeronautics, a contrivance, device, or structure intended to travel, glide, soar, or float in or through the air, or above the earth; a flying machine; an aircraft.

This term is applied to all aircraft, including balloons, airships, gliders, airplanes, rotary-wing aircraft, and experimental flying models, and is also applied, though infrequently, to guided rocket missiles and the like; this last usage, though rare, illustrates the need and search for an inclusive term for aircraft, rocket vehicles, and similar "machines." See CRAFT, sense 2 and note, VEHICLE and note; cf. FLYING MACHINE.

Mach line. A line representing a Mach wave; a MACH WAVE.

Machmeter, noun. An instrument that measures and indicates speed relative to the speed of sound, i. e., that indicates the Mach number. Also called a "Mach indicator."

Mach number. [Pronounced "mock." After Ernst Mach (1838-1916), Austrian scientist.] A number expressing the ratio of the speed of a body or of a point on a body with respect to the surrounding air or other fluid, or the speed of a flow, to the speed of sound in the medium; the speed represented by this number. Thus, a Mach number of 1.0 indicates a speed equal to the speed of sound, 0.5 a speed one half the speed of sound, 5.0 a speed five times the speed of sound, etc. See CRITICAL MACH NUMBER, FLIGHT MACH NUMBER.

Mach wave. 1. A shock wave theoretically occurring along a common line of intersection of all the pressure disturb-

ances emanating from an infinitesimally small particle moving at supersonic speed through a fluid medium, such a wave considered to exert no changes in the condition of the fluid passing through it. The concept of the Mach wave is used in defining and studying the realm of certain disturbances in a supersonic field of flow. 2. A very weak shock wave appearing, e. g., at the nose of a very sharp body, where the fluid undergoes no substantial change in direction.

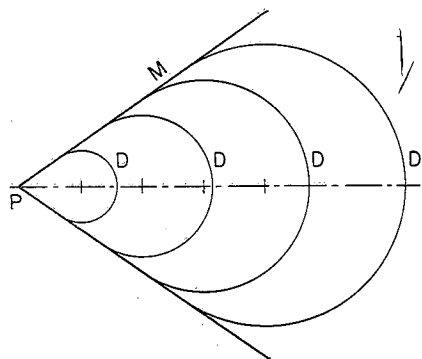

Mach wave, sense 1. Mach wave M from particle P moving at supersonic speed, outrunning its pressure disturbances D.

mag, noun. A clipped form of the word "magneto." Popular.

magnesyn, noun. [A trade name, from magnetic + synchronous; often capitalized.] An electromagnetic device that transmits the direction of a magnetic field from one coil to another, used to transmit measurements electrically from a point of measurement to an indicator in a remote-indicating system.

magnesyn compass. [See MAGNESYN.] A compass or compass system incorporating a flux gate and transmitting and receiving magnesyms for remote indication of the movements of the flux gate.

magnetic bearing. Bearing measured relative to magnetic north.

magnetic compass. A compass that uses a pivoted magnetic needle or other magnetic sensing element that aligns itself

with the earth's magnetic lines of force to indicate direction.

magnetic course. A course measured relative to magnetic north.

magnetic-drag tachometer. A MAGNETIC TACHOMETER.

magnetic heading. Heading measured relative to magnetic north.

magnetic north. The direction north as indicated by a magnetic compass influenced only by the earth's magnetic field.

Since the earth's magnetic lines of force are often irregular, magnetic north may not be in the direction of the north magnetic pole.

Magnetic north is sometimes confused with compass north.

magnetic tachometer. A type of tachometer in which a disk magnet, rotated mechanically or electrically, induces eddy currents in a nonmagnetic metal disk or cup mounted coaxially with it and rotates the nonmagnetic element to a degree proportional to the rotational speed of the magnet, indications of rpm being given by a pointer attached to the nonmagnetic element. Also called a "magnetic-drag tachometer."

magneto, noun. A type of electric generator using permanent magnets to supply an electric current for engine ignition.

magnetohydrodynamics, noun. The dynamics of the interaction between magnetic fields and electrically conducting fluids.

Magnus effect. [After Heinrich Gustav Magnus (1802-1870), German scientist.] A force acting substantially normal to the direction of relative motion of flow on a cylinder or sphere rotating in a flow. See CIRCULATION, note.

main-stage supercharger. In a setup where two or more superchargers are used, that supercharger which discharges into the intake manifold.

maneuver, noun. 1. A change in the movement or attitude of an aircraft in flight, such as a turn, a dive, a pull-out, a bank, etc. 2. An evolution or performance such as a loop, a roll, a wing-over, etc.

maneuver, verb tr. and intr. To put through, or to perform, a maneuver or maneuvers.

maneuverability, noun. The property of an aircraft that permits it to be ma-

neuvered easily, and to withstand the stresses imposed by maneuvers; the capability of a rocket missile or the like readily to alter its flight path.

maneuverable, adj. Capable of being maneuvered; responsive to controls.

maneuvering load. A load imposed upon an aircraft member or part by a maneuver, such as a dive, turn, loop, etc.

maneuvering valve. A valve fitted in the top of a balloon or gasbag for releasing gas.

manhole, noun. Specif., an opening, capable of being sealed, for entering the gasbag or ballonnet of an airship.

manifold absolute pressure. The pressure in the intake manifold of an engine, measured from zero and expressed in inches of mercury. Usually called simply manifold pressure.

manifold-pressure gauge. A gauge that measures the manifold absolute pressure of an engine.

manometer, noun. A gauge for measuring the pressure of gases or vapors. The sensitive element in the instrument may be a column of mercury in a U-shaped tube, an aneroid, etc.

marker, noun. Anything on the earth's surface used to mark or to point out something, such as a colored panel or a light (see CIRCLE MARKER, COURSE MARKER, DYE MARKER); specif., a LOCATION MARKER.

marker beacon. Any kind of beacon used as a marker; specif., a LOCATION MARKER.

marker light. Any light, or any one of a set of lights, that marks a particular object or area, such as a boundary light, obstruction light, or runway light.

mass balance. 1. Weight that brings about a desired balance under static or dynamic conditions. 2. A weight or counterpoise used to effect a desired condition of equilibrium, esp. about the hinge axis of an aircraft control surface.

mass ratio. Rocketry. The ratio of the mass of the propellant charge of a rocket to the total mass of the rocket, charged with the propellant.

mast, noun. A post, column, or upright structure, as: a. A post on an airplane's fuselage to which one end of an antenna is fastened, or an upright

structure containing an antenna. b. A column or upright structure on a rotary-wing aircraft supporting a rotor. Called also a "rotor mast." c. An upright structure or tower to which the nose of an airship is moored. Called also a "mooring mast." d. On certain early airplanes, a post or upright member used as a support, e. g., for bracing wires.

Cf. PYLON.

master station. In a hyperbolic navigation system, such as loran, that transmitting station which controls the transmissions of another station or of other stations. See HYPERBOLIC NAVIGATION and cf. SLAVE STATION.

M class. A class of Goodyear airships having a volume of 725,000 cubic feet.

mean aerodynamic chord. The chord of an imaginary rectangular airfoil that would have pitching moments throughout the flight range the same as those of an actual airfoil or combination of airfoils under consideration, calculated to make equations of aerodynamic forces applicable.

The mean aerodynamic chord is defined by the formula

$$\frac{2}{S} \int_0^{c/2} c^2 dy,$$

where c is the local chord, b is the span, S is the wing area, and y is the lateral coordinate.

mean blade-width ratio. The ratio of the mean width of a blade, esp. a propeller blade, to the diameter of the circle described by the tip of the rotating blade.

mean camber. The mean of the upper camber and lower camber of an airfoil, i. e., the curvature, or the amount of curvature, of the mean line of an airfoil profile from the chord.

This term is often shortened "camber"; thus, an airfoil that is symmetric about its chord, such as a biconvex airfoil, is called an "airfoil of zero camber."

mean chord. A mean aerodynamic chord or a mean geometric chord; specif., a MEAN GEOMETRIC CHORD.

mean effective pitch. Same as ZERO-THRUST PITCH. Sometimes loosely called "effective pitch" (which see, sense 2).

mean effective pressure. An average pressure inside the cylinders of an internal-combustion engine, based on some calculated or measured horse-

power; specif., same as INDICATED MEAN EFFECTIVE PRESSURE.

mean experimental pitch. Same as ZERO-THRUST PITCH.

mean free path. The average distance a molecule, such as an air molecule, travels between collisions with other molecules.

mean geometric chord. The average chord length of an airfoil, obtained by dividing the airfoil area by the span. Usually called simply "mean chord."

mean line. Specif., a line midway between the upper and lower contours of an airfoil profile.

mechanic, noun. Specif., a person trained in the maintenance and repair of aircraft or aircraft engines. See AIRCRAFT ENGINE MECHANIC, AIRCRAFT MECHANIC.

mechanical efficiency. Specif., the efficiency of the mechanical operation of an internal-combustion piston engine, expressed as the ratio of its brake horsepower to its indicated horsepower.

mechanical pilot. Same as AUTOMATIC PILOT.

mechanical tachometer. A shaft-driven tachometer.

Mechanical tachometers include the centrifugal tachometer, the chronometric tachometer, and some of the magnetic tachometers. Cf. ELECTRIC TACHOMETER.

mesosphere, noun. [Greek *mesos* ("middle"), thus, a middle sphere.] 1. A sphere or layer of the atmosphere between the ionosphere and the exosphere (about 250 to 600 miles). 2. A sphere or layer of the atmosphere between the top of the stratosphere and an unnamed layer where the minimum of temperature occurs (about 20 to 50 miles). In this sense the mesosphere is coextensive with the chemosphere.

metacenter, noun. The point of intersection of the vertical through the center of buoyancy of a body (such as a sea-plane hull or airship) and the vertical through the new center of buoyancy that occurs when the body is displaced. When the metacenter is above the center of gravity, the body is stable.

metacentric height. The distance between the center of gravity of a buoyant body and its metacenter.

metalclad airship. An airship having an envelope of light metal plating over a lightweight framework. See PRESSURE-RIGID AIRSHIP.

meteorograph, noun. An instrument or apparatus that records simultaneously the values of two or more meteorological phenomena, such as temperature, pressure, humidity, etc. Also called an "aerograph." See AEROMETEOROGRAPH, RADIOMETEOROGRAPH.

metering jet. A passage of particular size that regulates the flow of fuel in a carburetor.

microbarograph, noun. A highly sensitive barograph for recording small and rapid changes in atmospheric pressure.

middle marker. In an instrument landing system, a fan marker near the approach end of a runway. See FAN MARKER.

midwing monoplane. A monoplane whose wing is mounted approximately midway between the top and bottom of the fuselage.

military aviation. Aviation conducted by a military establishment—disting. esp. from commercial aviation. Cf. NAVAL AVIATION.

military rated power. The maximum power or thrust that a military aircraft engine can develop without damage for a period of time (e. g., 30 minutes) specified by qualified authority.

milk, verb tr. To milk the flaps. To deflect the flaps in a series of small-angle movements. Slang.

minimal flight path. The flight path between two points that affords the shortest possible time enroute.

The minimal flight path may be planned to take advantage of winds and pressure systems, and is thus not necessarily the shortest flight path between two points.

minimum, noun. The lowest condition or limit of ceiling, visibility, altitude, etc. at which flight operation is permitted, such as a circling minimum, the lowest altitude at which circling is permitted.

minimum flying speed. The lowest steady speed at which an airplane can maintain altitude under the given conditions and without ground effect.

minimum gliding angle. The shallowest or flattest gliding angle an aircraft can steadily maintain with no engine thrust.

minimum pressure point. Specif., the point on the surface of a body in a flow (such as an airfoil in an airflow) where the local stream static pressure is at a minimum.

missile, noun. Any object thrown, dropped, fired, launched, or otherwise projected with the purpose of striking a target. See GUIDED MISSILE (sense 2).

missile attitude. The position of a missile as determined by the relationship of its axes to some reference. See ATTITUDE.

mixed flow. Flow consisting of different types or kinds of flow; e. g., flows consisting of both subsonic and supersonic flow, or laminar and turbulent flow.

mixed-flow compressor. A rotary compressor through which the acceleration of fluid is partly radial and partly axial.

mixture control. Specif., a carburetor control for adjusting the fuel-air ratio. See ALTITUDE MIXTURE CONTROL, AUTOMATIC MIXTURE CONTROL.

mixture distribution. The distribution, with respect to both quantity and quality, of the fuel-air mixture supplied to the several cylinders of an engine.

mixture ratio. Specif., an air-fuel ratio or fuel-air ratio.

mixture setting. An adjustment of a mixture control so as to obtain a desired fuel flow.

A mixture setting may be made for best economy, a setting that provides the minimum fuel flow for the power output, or for best power, the setting that gives the least fuel flow when maximum power is developed. The so-called best setting is the setting which, by definition, results in a one-percent reduction in power from the best power setting, caused by a reduction in fuel flow only. See AUTO-LEAN, AUTO-RICH, FULL RICH.

mock-up, noun. A full-sized replica or dummy of something, such as an airplane, usually made of some substitute material, such as wood or clay, and sometimes incorporating actual functioning pieces of equipment, such as engines. A mock-up may be built for study or experiment.

model, noun. A replica of something, usually in miniature, as of an aircraft or aircraft component; specif., a replica having the same relative proportions as the original (a scale model). See DYNAMIC MODEL, SCALE MODEL.

mold line. A line formed by the intersection of two surfaces; also, the point of intersection of two lines—used as a reference line or point in developing fittings, frames, etc.

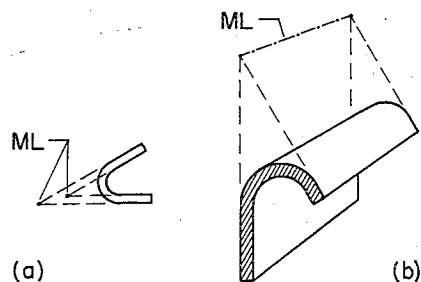

Mold lines.

moment, noun. *Specif.*, a tendency to cause rotation about a point or axis, as of a control surface about its hinge or of an airplane about its center of gravity; the measure of this tendency, equal to the product of the force and the perpendicular distance between the point or axis of rotation and the line of action of the force.

See DIVING MOMENT, HINGE MOMENT, PITCHING MOMENT, ROLLING MOMENT, TRIMMING MOMENT, YAWING MOMENT.

momentum pressure drop. A decrease in the static pressure of a fluid that balances an increase in momentum when the fluid is accelerated.

momentum theory. With respect to propeller and rotary-wing action, a theory which states that a propeller or rotary-wing system creates thrust or lift in reaction to the force required to accelerate a mass of air through its disk (see ACTUATOR DISK), the pressure differential before and behind the disk being equal to the rate of change of momentum of the air accelerated through the disk.

momentum thickness. In the study of fluid flow, a measure of the loss of momentum in a boundary layer with respect to the fluid momentum outside the boundary layer, indicating the thickness of the free-stream flow necessary to equal the momentum deficiency in the boundary layer. In compressible flow, the momentum thickness, θ , may be defined by the equation

$$\theta = \int_0^{\delta} \frac{\rho u}{\rho_0 U} \left(1 - \frac{u}{U}\right) dy,$$

where δ = boundary-layer thickness, ρ = local fluid density inside boundary layer, u = local velocity inside boundary layer, ρ_0 = local fluid density at edge of boundary layer, U = local ve-

locity at edge of boundary layer, and y = distance normal to surface. (For incompressible flow, $\rho = \rho_0$.)

monitor, verb tr. To observe, listen in on, keep track of, or exercise surveillance over by any appropriate means, as, to *monitor* radio signals; to *monitor* the flight of a missile by radar; to *monitor* a landing approach.

monocoque, noun. 1. A type of construction, as of an airplane fuselage, in which most or all the stresses are carried by the covering or skin. 2. Something embodying this type of construction, such as a fuselage or airfoil.

A monocoque may incorporate formers, but not longitudinal members. Cf. SEMI-MONOCOQUE, *noun*.

monocoque, adj. Built as a monocoque or embodying the principles of the monocoque, as in *monocoque* boom, *monocoque* design.

monofuel, noun. A MONOPROPELLANT.

monoplane, noun. An airplane having only one main supporting surface or wing, usually divided into two parts by the fuselage.

The monoplane, in its various styles, is now the commonest type of airplane. See HIGH-WING MONOPLANE, LOW-WING MONOPLANE, MIDWING MONOPLANE, PARASOL MONOPLANE, SHOULDER-WING MONOPLANE. See also DOUBLE MONOPLANE.

monoplane, adj. Having only one wing, as in *monoplane* fighter, *monoplane* glider.

monopropellant, noun. A rocket propellant consisting of a single substance, esp. a liquid, capable of producing a heated jet without the addition of a second substance. See ROCKET PROPELLANT.

Used attributively in phrases, such as monopropellant rocket engine or motor, monopropellant rocket fuel, monopropellant system, etc.

monospar, adj. Having or utilizing a single spar, as in *monospar* structure, *monospar* wing.

montgolfier, noun. A hot-air balloon, so named after Jacques (1745-1799) and Joseph (1740-1810) Montgolfier, who invented the type in 1783. See HOT-AIR BALLOON.

moor, verb tr. To hitch (an airship) to a mooring mast or to secure it to the ground; to secure (a balloon) to the ground; to tie up (a seaplane) to a dock, slip, or other place; to fasten (an airplane) to the ground or deck by means of cables, stakes, tie-downs, etc.

mooring, noun. 1. The act of securing or tying down an aircraft. See MOOR. 2. A place where an aircraft is moored, as, a *mooring* protected from winds. 3. *In plural.* The tackle or equipment used to moor an aircraft, as, a seaplane at its *moorings*.

mooring cone. A member shaped like a shallow cone capping the nose of an airship, to which the mooring devices are fastened.

mooring harness. A tackle of bands or tapes spread over an inflated balloon and used to distribute strains in mooring the balloon on the ground. Used chiefly with kite balloons.

mooring mast. A mast (which see, sense c) for mooring an airship. Some mooring masts are mobile or portable.

mosaic, noun. *Aerial Photography.* An assemblage of aerial photographs matched so as to form a continuous picture. See CONTROLLED MOSAIC, UNCONTROLLED MOSAIC.

mother aircraft. An aircraft from which another aircraft, a missile, or the like, such as a drone, is guided in flight; an aircraft that carries another aircraft, a large rocket missile, or the like, and launches and sometimes guides it. Also called a "parent aircraft." Cf. CARRIER AIRCRAFT, sense 2.

motor, noun. 1. A machine or apparatus that imparts motion or driving power, either to a vehicle or to a machine or mechanical apparatus. See note. 2. *Specif.*, a rotary machine that converts electric energy into work (electric motor).

"Motor" continues in good usage to be applied, though diminishingly, to internal-combustion reciprocating engines, despite efforts to suppress this application; custom also sanctions application of the word to rocket engines, but not to turbojet engines (except as they fall under the broad classification of "reaction motor") or to other gas-turbine engines.

Used in self-explanatory compounds, either in sense 1 or sense 2, as follows: motor armature, motor-driven, *adj.*, motor instrument (*rare*), motor mount, motor propellant (of a rocket), motor shaft, motor speed, motor thrust, motor torque, etc.

motorless, adj. Having no motor, or performed without a motor or without motor power, as in *motorless* flight (i. e., gliding or soaring flight), *motorless* glider (cf. POWER GLIDER).

mouse, noun. A bank of closely-spaced pressure-measuring tubes used to measure the pressures of a flow, esp. the

total pressures, near a bounding surface.

movable surface. An aileron, rudder, elevator, flap, or other primary control surface—disting. from a FIXED SURFACE.

moving target indicator. A radar indicator that permits cancellation of returns from fixed objects, showing returns from moving objects only.

muff, noun. A shroud of some kind surrounding a pipe or other object in any of various cooling, heating, or insulating systems, such as a cylinder around an exhaust collector or pipe through which carburetor air is passed for preheating. See HEAT EXCHANGER, sense 2.

multi-combining form. 1. Many. 2. More than one.

Compounds using this form include: *multibladed, multicell, multicylinder, multi-jet, multinozzle, multispar, etc.*

Whether this form is used in sense 1 or sense 2 is infrequently of importance, but where precision of meaning is necessary, context or the understanding of the reader can usually be relied upon for clarity. See following entries.

multiengine, or multiengineed, adj. Of aircraft: having two or more, or having more than two, engines, as in *multiengine* jet aircraft; *specif.*, without a qualifying word, having two or more, or more than two, internal-combustion piston engines, as in *multiengineed* flying boat.

The meanings "two or more," and "more than two," may be seen in such usage as the following: "Small single-engine aircraft do not require the long landing strip that *multiengine* aircraft do" (two or more); "In *multiengine* aircraft and large twin-engine aircraft a flight engineer is part of the crew" (more than two). See MULTI- and note.

multiplace, adj. Having space for more than one person. See PLACE.

multiplane, noun. 1. An airplane having two or more wings placed one above the other. 2. An airplane having three or more wings, or having many wings, placed one above the other.

Sense 1 includes the biplane and all other multiplanes, and is used for categorizing in distinction from the monoplane.

multiple combustion chamber. A combustion section of a gas-turbine engine consisting of a number of individual combustion chambers, or cans, surrounding the main shaft of the engine. See CAN, sense 1 and cf. CANNULAR COMBUSTION CHAMBER.

multiple-disk brake. A brake consisting of layered disks or rings, with stationary disks alternating with disks that rotate with the wheel or rotor. Application of pressure causing the disks to bear against each other provides braking action.

multiple-stage compressor. Same as MULTISTAGE COMPRESSOR.

multiple-stage rocket. Same as MULTISTAGE ROCKET.

multi-ropellant, noun. A rocket propellant consisting of two or more substances fed separately to the combustion chamber. See BIPROPELLANT.

multispar, adj. Having or utilizing more than two spars, as in *multispar* wing.

multispeed supercharger. A supercharger having two or more impeller gear ratios.

multistage compressor. An axial-flow compressor having two or more, or, usually, more than two stages of rotor

and stator blades; a radial-flow compressor having two or more impeller wheels. Also called a "multiple-stage compressor."

multistage rocket. A vehicle having two or more rocket units, each unit firing after the one in back of it has exhausted its propellant. Normally, each unit, or stage, is jettisoned after completing its firing. Also called a "multiple-stage rocket" or, sometimes, a "step rocket."

multistage supercharger. A supercharger having two or more impellers acting in series.

mush, verb, intr. Of an airplane: To settle or to gain little or no altitude while flying in a semistalled condition or at a high angle of attack.

M wing. A wing whose inboard sections are swept forward and whose outboard sections are swept back. Cf. W WING.

N

NACA cowling. A cowling designed by the National Advisory Committee for Aeronautics, consisting of a circular hood together with a part of the fuselage or nacelle behind the engine, providing a relatively low-drag body with a passage through it for a flow of cooling air.

nacelle, noun. A streamlined structure, housing, or compartment on an aircraft, as: a. A housing for an engine; a power car or gondola on an airship. See ENGINE NACELLE. b. A crew compartment or cabin of an airplane that does not have a conventional fuselage, i. e., where the tail surfaces are carried on one or more booms. c. A housing for some external component such as a loop antenna.

natural frequency. Generally, the frequency at which a freely vibrating (undamped) body oscillates.

nautical mile. A unit of distance equal to one minute of a great circle.

Because the earth is not a perfect sphere, several different values of the nautical mile are in use. The international nautical mile is taken to be 6076.10333 feet. This measure has been adopted by most maritime nations and is the measure accepted by the U. S. Department of Defense and the U. S. Department of Commerce. See KNOT.

naval aviation. Aviation conducted by a naval establishment—sometimes, for convenience, tacitly included within the general term "military aviation," but also sometimes disting. from military aviation.

navigable airspace. Airspace above certain minimum safe altitudes prescribed by proper authority, in which air navigation is permissible.

navigate, verb. 1. *tr.* To steer, direct, or guide (as a vessel or aircraft) from one place to another; also, to direct, guide or control the course of (a missile)—said of a person or of an automatic device or system, as, a device that *navigates* a missile along a desired path. 2. *intr.* To direct one's course from place to place, esp. in a vessel or aircraft; to perform navigation, as, a pilot who reconnoiters and *navigates* simultaneously.

navigation, noun. 1. The act or practice of navigating. 2. The art or science of guiding ships, aircraft, etc. from place to place, including determining position and distance traveled, and making use of any of several different methods or combinations of methods involving geometrical calculations, ref-

erence to celestial bodies, reference to landmarks, radio aids or other navigational aids, etc.; AIR NAVIGATION.

navigation aid, or navigational aid. Any instrument, device, installation, method, technique, facility, etc. that assists in navigation; specif., an AIR-NAVIGATION AID.

navigation computer. A kind of circular slide rule or calculator having scales for solving problems arising in navigation.

navigation dome. An ASTRODOME.

navigation instrument. An aircraft instrument that indicates, or that is used to ascertain, information relating to the position of an aircraft in flight, or to the direction in which it is flying. Navigation instruments include compasses, driftmeters, sextants, air-position indicators, radio compasses and other radio-navigation instruments, clocks, etc. See FLIGHT INSTRUMENT, note, and see also AIR-NAVIGATION AID.

navigation light. Any one of a group of lights mounted on an aircraft to make its dimensions, position, and direction of motion visible at night or under other conditions of poor visibility. Also called a "position light" or "running light."

Navigation lights are green (starboard), red (port) and clear (tail or nose). They are located on the tail and wing tips of airplanes and on the nose, envelope, and fins of airships.

navigator, noun. A member of the crew of an aircraft or vessel who plots its course or movement and ascertains its position; a person trained in the art of navigation.

N class. A class of Goodyear airships having a volume of 875,000 cubic feet.

negative acceleration. 1. Same as DECELERATION. 2. Accelerating force in a downward sense or direction, e. g., from top to bottom, head to seat, back to belly (of an aircraft), etc.; acceleration in the direction that this force is applied. See HEAD-TO-SEAT ACCELERATION.

negative dihedral. A downward inclination of a wing or other surface; ANHEDRAL. See DIHEDRAL.

negative g. A force acting on a body undergoing negative acceleration. See g.

negative lift. Lift acting in a downward direction. See LIFT, sense 1 and note.

negative thrust. REVERSE THRUST.

net, noun. A mesh rigging of rope or twine covering a balloon or gas cell to distribute or transmit loads or to restrain the envelope. See INFLATION NET.

net thrust. The gross thrust of a jet engine minus the drag due to the momentum of the incoming air.

neutral, adj. a. Of a control surface: Having neither positive nor negative displacement. b. Of a cockpit control: In a position corresponding to its neutral control surface.

neutral axis. Engineering. An axis that undergoes no stress in a beam, truss or the like subjected to bending.

neutral point. The location of the center of gravity of an aircraft for which static longitudinal stability would be neutral.

neutral stability. The stability of a body such that after it is disturbed it tends neither to return to its original state nor to move further from it, i. e., its motions or oscillations neither increase nor decrease in magnitude.

night airglow. Airglow (which see) discernible at night.

no-feathering axis. Same as AXIS OF NO FEATHERING.

no-flapping axis. Same as AXIS OF NO FLAPPING.

nondirectional, adj. Of a radio beacon, a signal, etc.: Not directional; OMNIDIRECTIONAL.

nonretractable landing gear. A FIXED LANDING GEAR.

nonrigid, noun. A nonrigid airship.

nonrigid airship. An airship without any rigid framework or keel, its form being maintained by the internal pressure of gas and by the air in the ballonets. This is the only type of airship presently used. See AIRSHIP and note.

nonviscous, adj. INVISCID.

normal axis. Specif., the Z-axis, or vertical axis. See AXIS, sense 2 and note.

normal climb. A regularly used climbing performance made at cruising airspeed and at more than cruising power but less than maximum power.

normal cruise. Cruise at a specified and regularly used percentage of rated horsepower.

normal glide. A glide in which the airplane travels the greatest horizontal distance for a given loss of altitude.

normal landing. A landing in which the airplane loses flying speed at the instant it makes contact with the surface in the manner usual for that airplane.

normal loop. The usual form of inside loop, in which the airplane, beginning from an upright flying position, passes successively through a backward-curving climb, inverted flight, and a curving dive, regaining its original attitude at the finish. See **INSIDE LOOP**.

normal power. **NORMAL RATED POWER.**

normal rated power. The maximum horsepower or thrust an engine can deliver for a protracted period of time without damage, as specified by the manufacturer or other qualified authority.

normal shock wave, or normal shock. A shock wave perpendicular, or substantially so, to the direction of flow.

normal spin. 1. A noninverted spin with the nose pointed steeply downward. 2. Specif., a spin initiated and continued at will and from which recovery may be effected within two turns.

In sense 2, sometimes called a "controlled spin."

nose, noun. The foremost point or part of a body, as of an aircraft, a rocket, a nacelle, an airfoil (the leading edge of an airfoil), etc. Cf. **BOW**.

nose, verb. 1. *tr.* To point or turn the nose of (an aircraft) in some direction while in flight—used with adverbs and prepositions, as in *to nose (an airplane) up, to nose down, to nose into*, etc. Also *intr.* of an aircraft or persons within, as, he *nosed down* toward the field. 2. *tr.* To turn (an airplane) over on its nose while moving on the ground—used with *over*. Also *intr.*

nose cap. A cap at the nose of an aircraft; esp., a **BOW CAP**.

nose cone. A cone or conelike section forming the foremost part of a rocket, of a fuselage, etc. See **MOORING CONE**.

nose dive. A steep dive of an airplane.

nose-down, adj. and adv. With the nose pointing downward, or tending to lower the nose, as in *nose-down* attitude, *nose-down* moment, or as, to fly *nose-down*.

nose gear. On some airplanes, that part of the landing gear which is situated at the nose.

noseheavy, adj. Having a tendency to sink at the nose. Applied esp. to airplanes. Cf. **BOWHEAVY, TAILHEAVY**.

nose-high, adj. and adv. **NOSE-UP.**
nose-low, adj. and adv. **NOSE-DOWN.**
nose-over, noun. An act or instance of nosing an airplane over on the ground. See **NOSE, verb, sense 2**.

nose rib. Same as **FALSE RIB**.

nose stiffening. **BOW STIFFENING.**

nose-up, adj. and adv. With the nose pointing upward, or tending to raise the nose, as in *nose-up* moment, or as, to glide *nose-up*.

nose wheel, or nosewheel, noun. A landing wheel in the nose gear of an airplane.

no-wind position. Same as **AIR POSITION.**

nozzle, noun. A duct, tube, pipe, spout, or the like through which a fluid is directed and from the open end of which the fluid is discharged, designed to meter the fluid or to produce a desired direction and type of discharge.

See **DE LAVAL NOZZLE, EXHAUST NOZZLE, JET NOZZLE, SUPERSONIC NOZZLE, TURBINE NOZZLE.**

nozzle blade. Any one of the blades or vanes in a nozzle diaphragm. Also called a "nozzle vane." See **NOZZLE DIAPHRAGM**.

nozzle box. In a turbosupercharger, a collecting chamber into which the exhaust gases from the engines are passed to exit through a series of nozzles onto the turbine wheel.

nozzle diaphragm. A kind of semipartition consisting of a ring of stationary, equally spaced blades or vanes forming an annulus of nozzles through which fluid is directed onto a turbine wheel, as in a gas-turbine engine. Sometimes called a "nozzle ring."

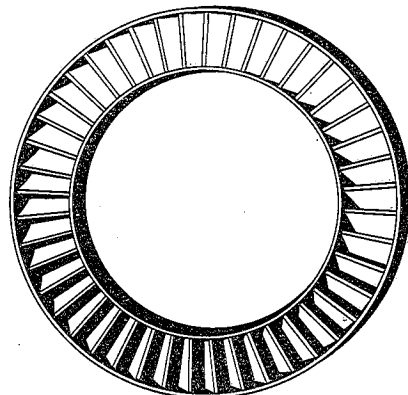

Nozzle diaphragm. Nozzle blades contained between inner and outer rings.

nozzle efficiency. The efficiency with which a nozzle converts potential energy into kinetic energy, commonly expressed as the ratio of the actual change in kinetic energy to the ideal change at the given pressure ratio.

nozzle ring. A **NOZZLE DIAPHRAGM**.

nozzle throat. The narrowest part of a nozzle.

nozzle vane. A **NOZZLE BLADE**.

N-struts, noun. A set of three struts, usually interplane struts, arranged like the letter "N."

nuclear reactor. An apparatus consisting of an arrangement of fissionable material together with a moderator (such as heavy water) and regulating devices, used to produce a controlled chain reaction for any of various purposes, as to generate heat. Also called a "pile" or "reactor."

oblique aerial photograph. An aerial photograph made with the optical axis of the camera at an angle to the vertical.

An oblique aerial photograph made with the optical axis at a large angle to the vertical, so as to include the horizon, is termed a high oblique; a photograph made at a smaller angle, not showing the horizon, is termed a low oblique.

oblique shock wave, or oblique shock. A shock wave inclined at an oblique angle to the direction of flow in a supersonic flow field.

observed altitude. *Nav.* The angular altitude of a celestial body above the celestial horizon of the observer.

observed brake horsepower. Same as **ACTUAL BRAKE HORSEPOWER**.

obstruction light. A light, or one of a group of lights, on a building, pole, tree, or other obstacle to flight to warn of the presence of the obstacle.

occulting light. A light that is shut off at intervals, the duration of the lighted period being equal to or greater than that of the dark period.

octane, noun. Any of a group of isomeric paraffinic hydrocarbons of eight carbon atoms. Specif.: a. Normal, or straight-chain, octane. b. **ISO-OCTANE**.

octane number or octane rating. A number given a fuel to indicate its antiknock quality, such number representing the percentage by volume of

nuclear turbojet. A turbojet engine having a nuclear reactor, rather than a combustion chamber, to heat the incoming air for expansion through the turbine and out the jet nozzle.

null, noun. A minimum radio signal or an absence of any signal, as in the transmitting pattern of an antenna or in the reception of a direction-finding set. See **AURAL NULL**.

Nusselt number. [After Wilhem Nusselt (1858-), German engineer.] A number expressing the ratio of convective to conductive heat transfer between a solid boundary and a moving

fluid, defined as $\frac{hl}{k}$, where h is the

heat-transfer coefficient, l is the characteristic length, and k is the thermal conductivity of the fluid.

iso-octane in a mixture of iso-octane and normal heptane that matches the antiknock property of the fuel being rated. Cf. PERFORMANCE NUMBER, note.

ogive, noun. A body of revolution formed by rotating a circular arc about an axis that intersects the arc; the shape of this body; also, a nose of a projectile or the like so shaped.

Typically, an ogive has the outline of a Gothic arch, although by definition it may be rounded rather than pointed. See **CONICAL OGIVE, DUCTED OGIVE, SECANT OGIVE, TANGENT OGIVE**.

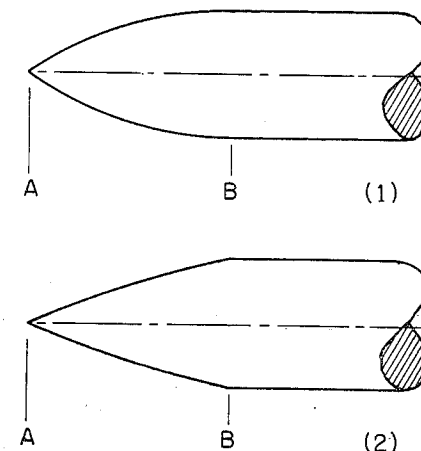

Ogives (ogive included between A and B). 1 tangent ogive; 2 secant ogive.

oilcan, *verb intr.* Of the sheet-metal skin of an aircraft or of other covering: To snap in and out between rows of rivets or between other places of support in a fashion like that of the bottom of an oilcan.

—oilcanning, *noun.* The action of snapping in and out, or the condition of a skin or covering deformed by this action.

oil cooler. A radiator for dissipating heat from lubricating oil. Also called an oil radiator.

oil-tank vent. A vent leading vapors or gases from an oil tank to an engine, or from an engine to an oil tank, thence to the open.

oleo, *noun*, or **oleo strut.** A telescoping landing-gear strut consisting essentially of a hollow piston that travels in an oil-filled cylinder, the oil, upon compression of the strut, being forced through a small orifice in the bottom of the piston to provide a shock-absorbing effect.

omni, *noun.* Airborne omnidirectional radio range receiving and indicating equipment. *Popular.*

omnidirectional, *adj.* That transmits or extends in all directions, as in *omnidirectional* beacon, *omnidirectional* pattern.

omnidirectional radio range. A type of radio range that gives bearings in all directions from the transmitter.

The omnidirectional radio range transmits two signals, one (the reference phase) having a constant phase throughout 360° of azimuth, the other having a variable phase. The two signals are in phase at magnetic north and out of phase in all other directions. By means of airborne equipment that measures the phase difference between the reference phase and the variable phase, a flier can find his bearing in terms of azimuth angle from magnetic north.

omnirange, *noun.* Same as *OMNIDIRECTIONAL RADIO RANGE.*

one-dimensional flow. Flow in which the fluid properties are assumed to vary only in one dimension, i. e., in the direction of the flow.

180-degree ambiguity. *AMBIGUITY.*

open-center system. A hydraulic system in which fluid flows through the selector valves set in the neutral position, no pressure being maintained when units are not in operation. *Cf. CLOSED-CENTER SYSTEM.*

open-circuit wind tunnel. A wind tunnel consisting essentially of a duct open at both ends, no provision being

made for recirculation. *Cf. CLOSED-CIRCUIT WIND TUNNEL.*

open-cycle engine. The ordinary kind of aircraft gas-turbine engine, in which air is drawn in from outside, heated by the combustion of fuel, and discharged, together with the combustion products, into the open. *Cf. CLOSED-CYCLE ENGINE.*

open-jet wind tunnel. Same as *OPEN-THROAT WIND TUNNEL.*

open-throat wind tunnel. A wind tunnel not having the test area enclosed by the tunnel walls. *Cf. CLOSED-THROAT WIND TUNNEL.*

operating line. A line on a graph representing the equilibrium (steady-state) operating conditions for a gas-turbine engine as the output is varied. The usual representations are compressor pressure ratio for ordinate and corrected engine speed or corrected airflow for abscissa.

operating weight. The weight of an aircraft equipped for flight. The term requires special definition whenever used, but usually included is the weight of oil, crew, crew's baggage, and emergency or extra equipment.

operations, *noun.* The organization or activity at an airport or air base that controls and directs flying operations.

opposed-cylinder engine. A reciprocating engine having its cylinders on opposite sides of the crankshaft. The cylinders are usually in the horizontal plane.

opposed-piston engine. A form of internal-combustion reciprocating engine in which two pistons work in opposition in each cylinder, driving different crankshafts.

orbit, *noun.* The path taken by a body or vehicle around a point or object, as by an airplane about an airport or other place.

orbit, *verb intr.* To fly or move around a point or object, as, a pilot who *orbits* about an aircraft carrier before landing.

ornithopter, *noun.* An aircraft designed to create lift by propulsion, or both, by means of flapping wings.

orthopter, *noun.* Same as *ORNITHOPTER.* *Rare.*

oscillate, *verb intr.* 1. To swing repeatedly back and forth, up and down, etc., as an aircraft about one of its axes.

2. To vibrate above and below a mean value.

oscillograph, *noun.* An oscilloscope, esp. a recording oscilloscope.

oscilloscope, *noun.* A device, usually including a cathode-ray tube, for representing visually the changes in an electric current or voltage. See *CATHODE-RAY TUBE.*

Otto cycle. [After N. A. Otto (1832-1891), German engineer.] A four-stroke cycle of operations for internal-combustion piston engines in which heat is added at essentially constant volume. See *FOUR-STROKE-CYCLE ENGINE.*

outboard, *adj.* Farther away from the hull or fuselage than another (component or section), as in *outboard* panel; farthest from the center line.

outboard, *adv.* Away from the center line, as, to displace (something) *outboard.*

outboard engine. The engine on either side of an airplane that is farther or farthest from the fuselage or hull.

outboard stabilizing float. A stabilizing float mounted much nearer to the wing tip than to the hull or fuselage of a seaplane. Also called a "wing-tip float."

outer chamber. Specif., in a gas-turbine engine, a casing containing a flame tube. See *COMBUSTION CHAMBER*, sense a.

outer cone. The casing, shaped like a truncated cone, of an exhaust-cone assembly. See *EXHAUST CONE.*

outer locator. Same as *OUTER MARKER.*

outer marker. In an instrument landing system, the outermost location marker from the end of the runway. See *FAN MARKER.*

outrigged, *adj.* Mounted on an outrigger, or mounted outboard, as in *outrigged* fin; projecting outward, as in *outrigged* girder. See *OUTRIGGER*, *adj.*

outrigger, *noun.* A frame, boom, or the like mounted on the main body but projecting away from it, as on an airship for mounting propellers or engines away from the car, on an airplane for supporting the tail surfaces, or on a rotorcraft for a rotor. See *BOOM*, sense a.

outrigger, *adj.* Used as an outrigger, as in *outrigger* boom; mounted outboard or attached to an outrigger, as

in *outrigger* float, *outrigger* wheel. See *OUTRIGGED.*

outside loop. A loop, usually entered from an upright flying position, in which the airplane's back remains toward the outside of the circle flown.

outside roll. A roll which the airplane begins and ends in inverted flight.

over-all efficiency. a. A net efficiency, i. e., the product of two or more efficiencies pertaining to the apparatus or system under consideration; specif., the efficiency with which an engine converts the heat energy of its fuel into effective propulsive energy, i. e., the product of thermal efficiency and propulsive efficiency. b. Same as *BRAKE THERMAL EFFICIENCY.* *Rare.*

over-all length. The dimension between the nose and tail extremities of an aircraft, rocket, etc. See *LENGTH* and note.

overbalance, *noun.* Specif., *AERODYNAMIC OVERBALANCE.*

overcast, *noun.* A cloud cover of all, or very nearly all, the sky; specif., a cloud cover of more than nine tenths of the sky.

overcontrol, *noun.* An act or instance of overcontrolling.

overcontrol, *verb intr.* Of a pilot: To displace or move an aircraft's controls more than is necessary for the desired performance.

overhang, *noun.* 1. On a biplane or other multiplane, an extension of one wing beyond another in a spanwise direction; the amount of this extension, equal to one half the difference in span of the two surfaces. 2. That part of a wing extending in a spanwise direction from the point of attachment of an outer strut, as on a high-wing monoplane; the distance between the outer-strut attachment and the wing tip. 3. That part of a balanced control surface that extends ahead of the hinge line; the amount by which the control surface extends ahead of this line.

overlap, *noun.* Specif., *VALVE OVERLAP.*

override, *verb tr.* To supplant or neutralize the operation or effect of an automatic control, esp. by a manually operated control.

overrun, *noun.* 1. An act or instance of an airplane rolling beyond the end of a runway in take-off or landing. 2. The area at either end of a runway which is cleared of obstructions and usually

graded or otherwise prepared to reduce danger from overruns or aborted take-offs.

overshoot, verb. 1. *tr.* To fly beyond (a mark or place) upon which a landing is intended. 2. *intr.* Of an aircraft or persons within: To perform an action as indicated in sense 1.

over-the-weather, adj. Above a region of bad weather or poor visibility, as in *over-the-weather* flying.

oxidant, noun. Specif., a substance (not necessarily containing oxygen) that supports the combustion reaction of a fuel or propellant.

oxidizer, noun. Specif., same as OXIDANT.

oximeter, noun. An instrument for measuring the oxygen saturation of the

blood, used, e. g., in a hypoxia warning system.

oxygen bottle. A small container for oxygen, used for breathing at high altitudes. See BAILOUT OXYGEN BOTTLE.

oxygen mask. A covering for the nose and lower face fitted out with special attachments for breathing oxygen.

The oxygen mask has provision for separating the expired breath from the incoming oxygen.

ozone layer. Same as OZONOSPHERE.

ozonosphere, noun. A layer or region in the atmosphere in which most of the ozone present in the atmosphere exists, beginning at about 13 miles above the surface and extending to about 22 miles or more.

P

pack, noun. Specif., a PARACHUTE PACK.

package, noun. Specif., any assembly or apparatus, complete in itself or practically so, identifiable as a unit and readily available for use or installation, such as an air-conditioning system for an aircraft, an engine, etc. See POWER PACKAGE.

paddle blade. A wide blade, esp. a propeller blade, with a tip more or less squared off.

pancake, verb tr. and intr. To put into, or to make, a pancake landing.

pancake landing. A landing in which the airplane is leveled off and stalled rather high above the surface, as a result of which the airplane settles rapidly on a steep flight path and strikes the surface forcefully.

panel, noun. 1. Any unit piece or block of fabric or similar material in the envelope of a balloon or airship, in the canopy of a parachute, etc. A gore (which see) in a parachute is ordinarily made up of several panels. See RIP PANEL. 2. Any strip or block of fabric laid out on the ground to identify the ground party to aircraft, to mark a position, etc. 3. A board of some kind holding controls or instruments, i. e., a CONTROL PANEL OR INSTRUMENT PANEL. 4. A section of an airplane wing. See WING PANEL.

pantobase, adj. Designating an airplane capable of taking off from and alighting on water, ice, snow, and almost any unprepared but fairly smooth and clear land surface, such as sand or swamp.

pants, noun. A set of teardrop-shaped fairings around the wheels of a fixed landing gear on certain airplanes. See SPAT.

PAR—Abbreviation for *precision approach radar*.

parabrake, noun. A DECELERATION PARACHUTE.

parachute, noun. 1. A contrivance, typically of light fabric without a stiffening framework, designed to create drag so as to slow down the descent or motion of any body to which it is attached. The common parachute used for descent consists principally of the canopy, the shroud lines, and the harness. 2. A PARACHUTE CANOPY. 3. A PARACHUTE PACK.

While the parachute was first designed, or envisioned at any rate, by Leonardo da Vinci (1452-1519), the first parachute jump is said to have been made by one Fouste Veranzio, from a tower in Venice, in 1617, using as a parachute a cloth-covered square framework. Promptly brought into use with the invention of the balloon, the parachute has been developed chiefly to permit safe leaps from great heights; other applications of the device have arisen, however, e. g., for the gentle lowering of air-sounding instruments, for braking airplane landing speeds, etc.

In senses 1 and 2, see ANTISPIN PARACHUTE, ATTACHED-TYPE PARACHUTE, CARGO PARACHUTE, DECELERATION PARACHUTE, FREE-TYPE PARACHUTE, PILOT PARACHUTE, RIBBON PARACHUTE; in sense 3, see BACK-PACK PARACHUTE, CHEST-PACK PARACHUTE, SEAT-PACK PARACHUTE. Also see ROTOCHUTE.

parachute, verb. 1. *intr.* To leap from a flying aircraft or from a height and descend to earth by means of a parachute. See note. 2. *tr.* To deliver or drop by parachute.

In sense 1, the verb is often followed by the adverbs *down* or *out*. See BAIL.

parachute boot. A container for a parachute, esp. on a rocket, from which the parachute is deployed to lower the rocket to earth.

parachute canopy. The umbrella-like main element of a parachute, which spreads out to catch the air.

parachute harness. The assembly of straps, buckles, etc. which fits around the body or around a burden to be dropped and to which a parachute pack is attached. See QUICK-RELEASE HARNESS.

parachute jump. An act or instance of leaping out of a flying aircraft or from a height and descending to earth by parachute.

parachute jumper. A PARACHUTIST.

parachute loft. A building or place where parachutes are serviced and stored.

parachute log. A log on a particular parachute, recording inspection, testing, repair, etc.

parachute pack. 1. A folded parachute, enclosed in a fabric container or wrapper, ready to be used. See PARACHUTE HARNESS. 2. The container that holds the folded parachute.

For different types of parachute packs, see PARACHUTE, *noun*, final note.

parachute rigger. A person who packs, repairs, inspects, and adjusts parachutes.

parachute troops. Soldiers organized, trained, and equipped to parachute into battle.

parachute vent. A distensible opening in the apex of a parachute, designed to relieve excessive air pressure inside the inflated canopy and so reduce the opening shock and the oscillation or swinging of the parachute.

parachutist, noun. One who parachutes; one who regularly makes, or who is trained to make, parachute jumps.

pararaft, noun. A raft, esp. an inflatable raft, designed to be dropped by parachute, or to be carried by a parachutist.

parasite drag, or parasitic drag. 1. As now generally accepted, any or all of the drag forces acting on an aircraft that are not formed in the production of lift; in subsonic flow, any or all of the drag forces acting on an aircraft exclusive of the induced drag. 2. In some contexts, esp. in the older literature, any or all of the drag forces from parts of the aircraft that do not contribute to the lift.

In sense 2, the parasite drag does not include profile drag. See INTERFERENCE DRAG.

parasol monoplane. A monoplane whose wing is mounted above the fuselage on struts.

Although sometimes classified as a "high-wing monoplane" (which see), the parasol monoplane is usually distinguished from the "high-wing" type.

paratrooper, noun. A member of the parachute troops.

parent aircraft. Same as MOTHER AIRCRAFT.

partial-admission turbine. A type of turbine in which the working substance is directed only through part of the annular area swept by the rotating turbine blades.

partial-panel flight. An instrument flight in which one or more of the usual instruments on the panel are inoperative or missing.

partial pressure. That part of the total pressure of a mixture, such as a gas mixture or gas-vapor mixture, that is contributed by one of the constituents.

pass, noun. A short, brief, run or movement of an aircraft in its flight, as by a fighter airplane in attacking an enemy aircraft, by a bomber at or over its target, by any airplane over an intended landing area, etc. In "dragging" a field, e. g., an airplane makes a *pass*. See DRAG, *verb*.

passenger, noun. Specif., a person other than a crew member who rides or travels in an aircraft, often a revenue-producing traveler.

This word is much-used as an attributive in compounds (all self-explanatory), such as passenger aircraft, passenger cabin, passenger door, passenger load, passenger manifest, passenger transport, etc.

passenger-mile, noun. One passenger carried one mile.

passing light. A very strong light or lamp, usually red, displayed on an aircraft to warn of the presence of the aircraft. The light may be variously located.

passive homing. The homing (which see) of a guided missile wherein the missile directs itself toward the target by means of energy waves transmitted or radiated by the target.

patch, noun. Specif., a piece of fabric or other material fastened against the envelope of an airship, etc., for any of various purposes, as: a. A piece of fabric secured to a gasbag to attach a line or cable and to distribute the load. See FINGER PATCH, SUSPENSION PATCH. b. A piece of material used to repair a rent or tear in an envelope, a canopy, etc., by covering it.

path, noun. A line of movement or a way; specif.: a. A FLIGHT PATH. b. A TRACK (in sense 1).

pathfinder, noun. One who or that which finds and marks a path or way—applied in military aviation to a flier, crew, or aircraft that finds a route to a target and marks the route and target, as by flares, sometimes checking and reporting on weather conditions, etc.

pattern, noun. Specif., the horizontal configuration or form of the flight path flown by an aircraft, or prescribed to be flown by aircraft, as in making an approach to a landing.

payload, noun. Also **pay load.** 1. Originally, the revenue-producing portion of an aircraft's load, e. g., passengers, cargo, mail, etc. 2. By extension, that which an aircraft, rocket, or the like carries over and above what is necessary for the operation of the vehicle for its flight.

peak pressure. A maximum pressure; specif., the maximum pressure reached during combustion in the cylinder of an internal-combustion reciprocating engine.

pedal, noun. Specif., a RUDDER PEDAL.

pelorus, noun. An instrument consisting of a compass card or bearing plate without any direction-seeking element but equipped with sighting vanes so that when the device is oriented visual bearings can be taken.

penetration, noun. Specif., that phase of the letdown from high altitude to a specified approach altitude.

percent-type tachometer. A tachometer that shows the percent of rotational speed as compared with the maximum allowable for the engine.

perfect fluid. In simplifying assumptions, a fluid chiefly characterized by nonviscosity and, usually, by incompressibility. Also called an "ideal fluid."

A perfect fluid is sometimes further characterized as homogeneous and continuous. See POTENTIAL FLOW.

performance, noun. The way in which something operates or performs, such as an engine, a propeller, an aircraft, etc.

The performance of an aircraft, for example, is judged by its speed, range, stability, rate of climb, and other qualities and capabilities (also referred to as flight characteristics and performance characteristics) as determined under the given conditions and measured against the appropriate criteria.

performance characteristic. A characteristic or capability exhibited by something in its operation or use.

The performance characteristics of an airplane, for example, include its rate of climb, speed, length of take-off and landing run, range, and ceiling; the performance characteristics of an engine include its power, fuel consumption, and endurance. See CHARACTERISTIC and note.

performance number. A number assigned to a fuel to represent the approximate average of the knock-limited performance (power output) of the fuel.

The performance-number scale is based on iso-octane at 100 (i. e., 100-octane fuel has a performance number of 100), the tested fuels being compared with leaded iso-octane. The scale has been extended to fuels below the 100 octane rating as well as to fuels having antiknock qualities above the 100-octane rating.

Two numbers in a performance number, e. g., 115/145, represent the lean and rich performance ratings, respectively.

performance-type glider. An advanced type of glider or sailplane having a high degree of aerodynamic refinement and a low minimum sinking speed, designed for extended soaring flight. Sometimes called a "high-performance sailplane."

peripheral speed. The linear speed in the direction of rotation at the outer edge of a rotating body, esp. a turbine wheel or compressor rotor. Cf. ROTOR SPEED, TIP SPEED.

permeability, noun. With respect to fabric or material used for the gasbags or envelopes of balloons and airships,

the capability of the material to allow the aerostatic gas to pass through; the rate of diffusion of a gas through a material, as measured over a unit area under standard conditions.

phototheodolite, noun. An instrument or device incorporating one or more cameras (sometimes a motion-picture camera) for taking and recording angular measurements and having various uses. In aeronautics, the phototheodolite, sometimes in conjunction with radar equipment, is used to track aircraft, rockets, etc. to measure and record attitude, altitude, azimuth and elevation angles, etc.

phugoid oscillation. A long-period longitudinal oscillation consisting of shallow climbing and diving motions about a median flight path and involving little or no change in angle of attack.

pibal, or PIBAL, noun. [From "pilot balloon."] Same as PILOT BALLOON.

pick-off, noun. A sensing device, used in combination with a gyroscope in an automatic pilot or other automatic or robotic apparatus, that responds to angular movement to create a signal or to effect some type of control. A pick-off may be a potentiometer, a photoelectric device, a kind of valve controlling the fluid flows and pressures in a system, or one of various other devices. See AIR PICK-OFF.

piezometer ring. A pipe or tube in the form of a ring, used to connect a number of taps for pressure measurement in a duct or passage.

pile, noun. A NUCLEAR REACTOR.

pilot, noun. 1. A person who flies an aircraft, i. e., who rides in the aircraft and handles its controls so as to guide it in the desired manner of flight; a person trained or rated to fly an aircraft. See BALLOON PILOT, and cf. CO-PILOT, sense 1 and FLIGHT OPERATOR. 2. AN AIRSHIP PILOT. 3. AN AUTOMATIC PILOT.

pilot, verb. 1. *tr.* To act or serve as the pilot of. 2. *intr.* To act or serve as pilot.

pilotage, noun. Specif., air navigation by visual reference to landmarks, esp. with the aid of maps or charts. Also called "piloting."

pilot balloon. Meteorol. A small free balloon sent up and tracked with a theodolite to find the direction and

speed of the wind from the drifting movement of the balloon. It may also serve as a ceiling balloon. Sometimes called a "pibal."

pilot certificate. A certificate issued a person by the Federal Aviation Agency granting authorization to operate aircraft to an extent limited by the type of certificate and the rating of the holder. Types of certificates include airline transport certificate, commercial certificate, private certificate, private glider certificate, student certificate, etc.

pilot chute. A PILOT PARACHUTE. *Popular.*

piloting, noun. 1. The action of the verb *pilot*. 2. Same as PILOTAGE.

pilotless aircraft. An aircraft, esp. an airplane (pilotless airplane), specially designed or equipped to fly and perform its function or mission without a human pilot aboard.

The term "pilotless aircraft" is sometimes used *generically* to embrace all kinds of pilotless vehicles, whether aircraft or not, but this extension of meaning is restricted to special circumstances and is not recognized in common usage. See AIRCRAFT and note, DRONE.

pilotless bomber. Specif., a winged guided missile without a human pilot, designed to be launched against surface targets—an AF term.

pilot parachute. A small auxiliary parachute attached to the apex of the main parachute, designed to pull the latter out of its pack.

pinwheel, noun. A rotary-wing aircraft. *Slang.*

pip, noun. Same as BLIP.

piston displacement. In a reciprocating engine, the total volume within the cylinder or cylinders displaced during one stroke of each piston.

piston engine. Same as RECIPROCATING ENGINE.

—piston-engine(d), *adj.*, as in *piston-engine(d)* airplane.

pitch, noun. 1. The cant or slant of a chosen chord of a propeller blade, rotor blade, or other blade with respect to a plane perpendicular to the axis of rotation of the blade; BLADE ANGLE. See EFFECTIVE PITCH, EXPERIMENTAL PITCH, ZERO-THRUST PITCH. 2. Specif., GEOMETRIC PITCH. 3. a. The rotational or oscillatory movement of an aircraft, rocket missile, etc. about a lateral axis, or pitch axis; pitching. b. The

amount of this movement, i. e., the ANGLE OF PITCH.

pitch, verb. 1. *intr.* To rotate or oscillate about a lateral axis. 2. *tr.* To cause to rotate about a lateral axis.

pitch angle. 1. Same as BLADE ANGLE (in all senses). 2. Same as ANGLE OF PITCH.

pitch attitude. The attitude of an aircraft, rocket missile, etc. referred to the relationship between the longitudinal body axis and a chosen reference line or plane as seen from the side.

pitch axis. A lateral axis through an aircraft, missile, or similar body, about which the body pitches. It may be a body, wind, or stability axis. Also called a "pitching axis." See AXIS, sense 2 and note.

pitch control. Any mechanism or device that controls or regulates pitch, either of a blade or of an aircraft, rocket missile, etc.

pitch distribution. The distribution or spread of various blade angles along a blade, accounting for twist.

pitch indicator. 1. An instrument that indicates the amount of pitch or the rate of pitch of an aircraft or other body. See ARTIFICIAL HORIZON, sense 1. 2. An instrument that indicates the amount of pitch of a blade.

pitching, noun. The action of rotating or oscillating about the lateral axis; pitch (in sense 3a, which see).

pitching axis. Same as PITCH AXIS.

pitching moment. A moment about a lateral axis of an aircraft, rocket, airfoil, etc. This moment is positive when it tends to increase the angle of attack, or to nose the body upward.

pitch lever. A lever for changing the collective pitch of a rotor. Cf. CYCLIC PITCH STICK.

pitch-under, noun. An act or instance of an aircraft pitching nose downward; a tendency of an aircraft to pitch nose downward. See TUCK and note.

pitch-up, noun. An act or instance of an aircraft pitching nose upward; a tendency of an aircraft to pitch nose upward. See TUCK and note.

pitot, noun. A PITOT TUBE.

pitot head. 1. Loosely, a PITOT-STATIC HEAD. 2. A PITOT TUBE. *Rare.*

pitot pressure. The pressure received in a pitot tube. It is the stagnation pres-

sure at the tube. See PITOT-STATIC TUBE (illus.) and STAGNATION PRESSURE.

pitot-static head. A device consisting of a pitot tube and a static tube assembled as a unit, esp. in a coaxial arrangement or with the static tube otherwise enclosing the pitot tube, together with any heating elements or other parts identified with the unit; a PITOT-STATIC TUBE.

pitot-static tube. A device consisting essentially of a unit combination of a pitot tube and a static tube arranged coaxially or otherwise parallel to one another, used principally in measuring impact and static pressures; a PITOT-STATIC HEAD.

The difference between impact and static pressures is used to measure the velocity of flow past the tube by means of an airspeed indicator. The static pressure from a pitot-static tube may in addition be used in the operation of an altimeter and similar instruments.

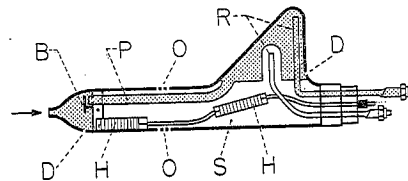

One form of pitot-static tube, or head (in longitudinal section). P pitot tube; S static tube; R risers; O static-pressure holes; D drain holes; H heaters; B baffle. Shaded area contains pitot pressure.

pitot tube. [Pronounced "pee-toe." After Henri Pitot (1695-1771), French scientist.] 1. An open-ended tube or tube arrangement which, when immersed in a moving fluid with its mouth pointed upstream, may be used to measure the stagnation pressure of the fluid. 2. Loosely, a PITOT-STATIC TUBE.

pitot-venturi tube. A combination pitot tube and venturi tube for measuring airspeed.

placard, noun. Specif., a posted notice on or in an aircraft setting forth a requirement or limiting condition in operation.

placard, verb tr. To post with a placard, as, the airplane was placarded at 150 mph; to limit by a placard, as, to placard engine temperature.

—placarded, *adj.*, as in placarded critical Mach number. See PLACARD, *adj.*

placard, adj. Posted with, or limited with, a placard, as in placard speed, a limiting speed. See PLACARD, *verb*, and note.

place, noun. A cockpit, seat, or station on an aircraft for one person.

This word is used as an element in combinations such as two-place, multiplace, etc., the place or places for the pilot or crew being included in the figure. Such terms are not customarily applied to transport or passenger aircraft. See SEAT and note.

plain flap. The elemental flap—nonextensible, nonslotted, and nonsplit—hinged to a wing and forming part of the trailing edge. Also called a "simple flap."

plane, noun. 1. An airplane. Also used in combinations, such as landplane, lightplane, skiplane. 2. A broad and thin structure that obtains a reaction with the wind, i.e., an airfoil, or surface. *Obs.* in this sense except in terms such as main plane, tail plane, biplane elevator, etc.; it appears vestigially in airplane, biplane, monoplane, etc.

plane, verb intr. To hydroplane. See HYDROPLANE, *verb*.

plane of rotation. The plane in which an object such as a propeller rotates; specif., a plane in which a rotary-wing system rotates, or is assumed to rotate. Cf. TIP-PATH PLANE.

plane of symmetry. A plane passed through a body or object, such as an airplane or airship, about which both halves of the body or object have the same form and dimensions.

The plane of symmetry of an aircraft is a vertical plane containing the longitudinal axis.

planform, noun. The outline of an object, such as a wing, as viewed from above.

With respect to wings and other surfaces particularly, "planform," as defined above, is sometimes called the projected planform, as disting. from the developed planform, in which the chords and axis of the airfoil are brought into a plane parallel to the plane of projection. The developed planform of an airfoil is thus larger than its projected planform.

planing surface. The bottom surface of a float or hull, designed for hydroplaning.

plan-position indicator. A type of radar set that gives a maplike presentation on a circular screen, indicating the range and azimuth of any discernible object respective to a point on the

screen representing the location of the transmitter.

plasma, noun. An electrically neutral, conductive, partially ionized gas.

plastic deformation. The permanent deformation of a material beyond its elastic limit, i. e., beyond the limit of the material to return of itself to its original shape.

plenum chamber. Specif., a chamber in certain ducting systems, as in a gas-turbine engine, that receives ram air for the compressor.

plotter, noun. Specif., a kind of rule or scale for drawing and measuring courses and distances on a chart.

plug aileron. A retractable aileron that fits into and closes a slot in the wing when retracted. It is a type of spoiler-slot aileron.

pneudraulic, adj. Operating by the resistance or pressures afforded by liquid and compressed air or gas working together, as in pneudraulic shock strut, a shock-absorbing strut in which the piston works against both the hydraulic action of a fluid and against a highly-compressed gas, the gas tending to return the piston to its extended position.

pod, noun. An enclosure, housing, or detachable container of some kind, as: a. A detachable compartment on certain airplanes for the cargo or other load. b. An ENGINE POD. c. AN EJECTION CAPSULE.

point of no return. The point along a line of flight at which an aircraft cannot return to its place of departure on its fuel supply.

polar distance. The angular distance of a celestial body from a celestial pole, measured along the hour circle from the celestial pole to the body from 0° through 180°. See CO-DECLINATION.

polytropic compressor efficiency. The efficiency of a compressor expressed as the ratio of the work of compression for an ideal polytropic process between fixed states of the gas to the work of compression for the actual process between the same states. See COMPRESSOR EFFICIENCY.

pontoon, noun. Specif., same as FLOAT.

porosity, noun. The quality or state of having pores or interstices, as of parachute or airship fabric. See PERMEABILITY.

porpoise, verb intr. Of a seaplane or flying boat: To jump and plunge, in the manner of a porpoise, while moving on the water; technically, to oscillate vertically and about the lateral axis while moving on the water.

port, noun. 1. a. The left side of an aircraft or vessel. b. The area or direction to one's left, as, to turn to *port*. See *LEFT, noun and adj.* 2. An opening of some kind, as: a. A circular window in the side of an aircraft fuselage, hull, or cabin, or a side aperture for a gun, a camera, etc. b. An opening in an engine cylinder for the passage of the fuel-air mixture or one for the passage of exhaust gases. 3. Short for *AIRPORT*.

port, adj. Situated on or at the left, as in *port aileron*; coming from the left, as in *port wind*. See *LEFT, adj.*

position, noun. Specif.: 1. The location of an aircraft, guided missile, or the like with respect to geographical coordinates, a city, a topographical feature, etc. The term is more general than "fix" (which see). 2. The attitude of an aircraft, rocket, etc. 3. The angular placement of a movable surface about its hinge axis. 4. A crew member's station aboard an aircraft.

position error. An error in the reading of an airspeed indicator owing to the difference between the pressure (esp. the static pressure) at the pressure-measuring location and the free-stream pressure.

position indicator. An instrument or device that shows the location of an aircraft, the deflection of a control surface, etc.

See *AIR-POSITION INDICATOR, FLAP-POSITION INDICATOR, GROUND-POSITION INDICATOR, LANDING-GEAR INDICATOR.*

position light. Same as *NAVIGATION LIGHT*.

position line. Same as *LINE OF POSITION*.

position report. A report from an aircraft in flight to a controlling station giving the aircraft's position, often together with other information, such as heading, speed, etc.

positive acceleration. 1. Acceleration such that speed increases. See *ACCELERATION, sense 2, and cf. ACCELERATION, sense 1.* 2. Accelerating force in an upward sense or direction, e. g., from bottom to top, seat to head, belly to back (of an aircraft), etc.; acceleration in the direction that this force is

applied. See *SEAT-TO-HEAD ACCELERATION*.

positive dihedral. An upward inclination of a wing or other surface (from root to tip). Usually called "dihedral" (which see, sense 1a).

positive-displacement compressor. A compressor, such as a piston-type compressor, that displaces a fixed volume of fluid with each stroke or revolution.

positive g. A force acting on a body undergoing positive acceleration. See *g*.

positive lift. Lift acting in an upward direction. See *LIFT, sense 1 and note*.

postflight, adj. After a flight, as in *postflight inspection*.

postignition, noun. The ignition of the mixture in the cylinder of a spark-ignition engine after the cessation of the electrical igniting spark.

potential flow. A frictionless, irrotational flow—applied to nonturbulent flows approximating this condition, for the sake of simplicity in developing formulas and equations.

potential temperature. The temperature a gas would have if brought adiabatically from a given initial condition to a certain final condition; specif., *Meteorol.*, the temperature a parcel of air would have if brought adiabatically to a pressure of 1000 millibars.

potentiometer, noun. Specif., an instrument or device that measures or compares the electrical potential, or electromotive force, between two points.

Properly hooked up to a deflecting component, such as an aircraft control surface, a potentiometer can be used to measure angular movement; the device can also be used for measuring temperature, fuel level in a tank, etc.

pound, noun. Specif., a unit of measurement for the thrust or force of a reaction engine, representing the weight the engine can move, as, an engine with 5000 *pounds* of thrust.

pound-mile, noun. One pound carried one mile.

pour point. The highest temperature at which an oil will not flow under prescribed test conditions; specif., the highest temperature at which an oil will not flow from the mouth of a testing vessel held in a steady horizontal position for five seconds.

power approach. A landing approach during which the airplane is under power (as contrasted to power-off glid-

ing approach), used esp. to provide better control.

power car. A car housing an engine on an airship. Also called an "engine car."

Power cars were used chiefly on rigid airships and some semirigid airships. On non-rigid airships the practice is to attach the engines to the main car by means of outriggers or to mount the engines in the main car.

power compensator. An economizer (which see) in a carburetor.

power dive. A dive in an airplane, esp. a steep dive, under considerable or full power.

—*power-dive, verb tr. and intr.*, as, to *power-dive* an airplane, or, a pilot who *power-dives*.

power glider. A glider equipped with a power plant for optional powered flight. On some power gliders, esp. military types, the power plant may serve only to flatten the gliding angle with the craft under maximum load.

power landing. An airplane landing in which the airplane is under power until it touches down.

power loading. The ratio of the gross weight of a propeller-driven aircraft to its power, usually expressed as the gross weight of the aircraft divided by the rated horsepower of the power plant corrected for air of standard density. With turboprop engines, the equivalent shaft horsepower is used. Cf. *THRUST LOADING*.

power package. An engine, esp. a reciprocating engine, together with its accessories, lines, cowling, etc., ready for quick installation on an aircraft.

power plant. Also *powerplant, noun.* 1. The complete assemblage or installation of engine or engines, accessories, induction system, cooling system, ignition system, etc. that generates the motive power for a self-propelled vehicle or vessel such as an aircraft or guided missile, an automobile, etc. See note. 2. An engine or engine installation regarded as a source of power.

In sense 1, with regard to aircraft power plants, no generally accepted and fixed definition of "power plant" exists with respect to what items or components, other than the engine or engines, are specifically included or excluded as a part of the power plant. Where such a definition is required, it is customary to include it in context. The definition commonly includes, in addition to the engine or engines, any propellers, the accessories, the induction, cooling, and ignition systems, and (less often) all fuel lines and tanks—in this sense sometimes also called the powerplant group.

power setting. The setting of any control or regulator that affects the output of an engine or power plant, such as a throttle setting, a mixture-control setting, or a propeller-pitch setting.

power-stall landing. A landing in which the airplane is put into a landing attitude under power some distance above the surface and allowed to settle gradually under power.

power stroke. In a four-stroke-cycle engine, the stroke or movement of the piston as it is pushed by the burning gases of combustion, thus delivering power. Sometimes called the "expansion stroke."

PPI—Abbreviation for *plan-position indicator*.

Prandtl-Meyer expansion. In two-dimensional flow, the acceleration and associated reduction in pressure and density that occurs where a supersonic stream flows around a corner or curve with no separation or losses.

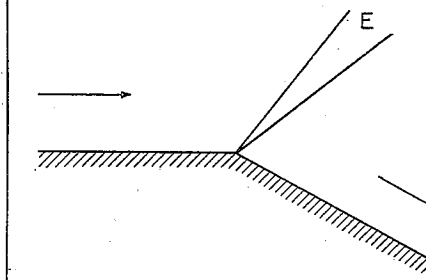

Prandtl-Meyer expansion E.

Prandtl number. [After Ludwig Prandtl (1875–1953), German scientist.] A dimensionless number representing the ratio of momentum transport to heat transport in a flow, defined by the

equation $N_{Pr} = \frac{\mu c_p}{k}$, where μ is the viscosity coefficient, c_p is the specific heat at constant pressure, and k is the coefficient of thermal conductivity.

prang, verb. [Onomatopoeic.] *tr. and intr.* To crash or crash-land. *Slang.*

Pratt truss. [After Caleb and Thomas Pratt, who developed the type for bridges in 1844.] A truss with tensioned cross-bracing rods, wires, or cables between uprights or side-by-side members, used in certain fuselages or airfoils.

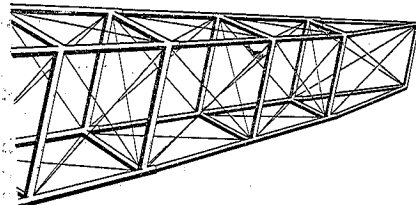

Pratt truss (fuselage).

precipitation static. Static resulting from particles in the atmosphere, such as water, sleet, dust, or sand particles, striking a receiving antenna or the surfaces of an aircraft.

precision approach radar. Radar equipment or a radar system used in an airport traffic control system, that displays, on radar screens in the airport control tower, highly accurate indications of the range, azimuth, and elevation of aircraft on approach to a landing. Used in conjunction with airport surveillance radar. See AIRPORT SURVEILLANCE RADAR.

precision landing. Same as ACCURACY LANDING.

precision spin. A planned spin in which the airplane is made to enter the spin from a particular heading and is caused to recover on a desired heading after a predetermined number of turns.

precombustion chamber. 1. In a compression-ignition engine, a small auxiliary combustion chamber in which the fuel is burned in the presence of insufficient air, and from which the combustion products expand turbulently into the main combustion chamber, where burning is completed. 2. In a rocket, a chamber in which the propellants are ignited and from which the burning mixture expands torchlike to ignite the mixture in the main chamber.

preflight, adj. 1. Before a flight, as in *preflight* planning. 2. Of or pertaining to activities, etc. preceding training involving flight, as in *preflight* school.

preignition, noun. The ignition of the mixture in the cylinder of a spark-ignition engine earlier in the cycle than the occurrence of the electric igniting spark, caused, e. g., by a hot spot in the cylinder wall.

prerotation, noun. Rotation in advance, as: a. The rotation of air, as by guide

vanes, before entering a rotary compressor, a fan, etc. b. The rotation of landing-gear wheels before touching down, esp. to reduce landing-gear loads.

presentation, noun. In electronics, the act or process of displaying radar echoes on a cathode-ray screen; the echo or images displayed on a cathode-ray screen.

preset guidance. A type of missile guidance in which devices in the missile, adjusted before launching, control the path of the missile.

pressure, noun. A force distributed over an area; specif., force per unit area.

See AIR PRESSURE, DYNAMIC PRESSURE, IMPACT PRESSURE, PARTIAL PRESSURE, PILOT PRESSURE, RELATIVE PRESSURE, STAGNATION PRESSURE, STATIC PRESSURE, STATION PRESSURE, TOTAL PRESSURE, VAPOR PRESSURE.

pressure accumulator. An accumulator (which see) that stores fluid under pressure, esp. an accumulator in a hydraulic system.

pressure airship. An airship that maintains its form, either wholly or in part, by internal pressure. Nonrigid, semi-rigid, and pressure-rigid airships are pressure airships.

pressure altimeter. An altimeter that utilizes the change of atmospheric pressure with height to measure altitude. It is commonly an aneroid altimeter (see ANEROID, *adj.*, sense 1), and is also called a "barometric altimeter." See ALTIMETER.

pressure altitude. 1. a. altitude above the standard datum plane, i. e., altitude measured from standard sea-level pressure (29.92" Hg) by a pressure, or barometric, altimeter. Although this altitude may be either an indicated altitude or a calibrated altitude, it is commonly considered to be calibrated. See INDICATED PRESSURE ALTITUDE. b. The altitude in a standard atmosphere corresponding to a given atmospheric pressure actually encountered. 2. The simulated altitude condition created in an altitude chamber by changing (usually by lowering) the pressure in the chamber.

Cf. PRESSURE HEIGHT.

pressure baffle. A baffle installed between, and partially around, adjacent cylinders on an air-cooled engine, designed to create a pressure difference so as to force cooling air to the rear of the cylinders.

pressure breathing. The breathing of oxygen or of a suitable mixture of gases at a pressure higher than the surrounding pressure.

See CONTINUOUS PRESSURE BREATHING, INTERMITTENT PRESSURE BREATHING.

pressure coefficient. Specif., a coefficient expressing the static pressure at any point in a flow in terms of its value with respect to free-stream static pressure and dynamic pressure, i. e.,

$$c_p = \frac{p_0 - p}{q}$$

where

c_p = pressure coefficient

p_0 = free-stream static pressure

p = pressure at some point in the flow

q = free-stream dynamic pressure

pressure-demand oxygen system. A demand oxygen system that furnishes oxygen at a pressure higher than atmospheric pressure above a certain altitude. See DEMAND OXYGEN SYSTEM.

pressure distribution. The distribution or disposition of the various pressures acting on a surface or area.

pressure drag. The drag on a body moving in a fluid medium due to the aerodynamic pressure distribution on the body, the net effect of which is to retard the body in its movement. See BASE DRAG, FORM DRAG.

pressure drop. A decrease in pressure, esp. from one point in a flow to another. See FRICTION PRESSURE DROP, MOMENTUM PRESSURE DROP.

pressure gradient. A change in the pressure of a gas or fluid per unit of distance.

A pressure gradient of increasing static pressure in the direction of flow is considered positive. See ADVERSE PRESSURE GRADIENT, FAVORABLE PRESSURE GRADIENT.

pressure head. 1. See HEAD, sense 2. 2. A device that projects into a field of flow to measure pressures. Usually called a "head."

pressure height. 1. The height at which the gas cells or the gasbag of an airship or balloon becomes filled with the expanded lifting gas. 2. Same as PRESSURE ALTITUDE (esp. in sense 1).

pressure-injection carburetor. Same as INJECTION CARBURETOR.

pressure jet. A kind of cup or a small combustion chamber at or near the tip of a rotor blade, which turns the rotor by ejecting a fluid jet. The pressure

jet may eject compressed air or exhaust gases from a central power plant or exhaust gases from combustion occurring inside the jet. See JET ROTOR.

pressure orifice. A flush orifice in a surface, to which a pressure measuring device is connected.

pressure-pattern flying. Flying and navigating an aircraft with consideration of the atmospheric pressure distributions so as to take advantage of favorable winds, the object being to achieve the shortest time en route.

pressure ratio. The ratio between two pressures, as between the chamber pressure and the nozzle pressure of a rocket. See COMPRESSOR PRESSURE RATIO and cf. COMPRESSION RATIO.

pressure-rigid airship. An airship that maintains form both by means of a light rigid framework and internal pressure. Applied specifically to the metalclad *Z. M. C.-2*, built in the late 1920's. See AIRSHIP and note.

pressure suit. A suit designed to maintain pressure over all or part of the body under conditions of low ambient pressure. Cf. G-SUIT.

pressure switch. A switch that is activated under a given pressure differential, as in a hydraulic system.

pressurized, noun. [A trade name, from "pressure control"; often capitalized.] A regulating or controlling apparatus consisting essentially of a pressure-responsive sealed bellowslike device enclosed within a chamber, used, e. g., in a turbosupercharger to control the waste gate according to pressure.

pressurize, verb tr. 1. To introduce and maintain a higher-than-ambient pressure inside of, as, to *pressurize* an aircraft or aircraft cabin, a fuel tank, etc. 2. To subject to a higher-than-ambient pressure, as, to *pressurize* a person, a part of the body, an electrical component, fuel, etc.

—*pressurization, noun, pressurized, adj.*, as in *pressurized* cockpit, *pressurized* oil, etc.

primary, noun. Specif., a PRIMARY GLIDER.

primary air. Air introduced into a combustion chamber, as in a turbojet engine, to support combustion of the fuel—distinct from SECONDARY AIR.

primary glider. A ruggedly built glider, typically having an open-framework fuselage, for the elementary training

of glider pilots. The craft is designed chiefly for gliding, rather than soaring.

primary structure. The structural elements of an aircraft that carry the major portion of the critical loads, principally, in an airplane, the main structural members of the wings, fuselage, empennage, and the landing gear, together with their fittings and braces. Elements not a part of the primary structure include cowlings, fairings, windshields, etc.

prime, verb tr. Specif., to introduce fuel into the induction system or cylinders of an engine before starting as an aid in firing the engine.

primer, noun. 1. A PRIMING PUMP. 2. A substance that burns or explodes when subjected to heat (as supplied, e. g., by percussion or electricity), used to initiate a combustion or explosion in another substance, as in a rocket igniter.

priming pump. A pump, such as a wobble pump, for priming an engine. Often called a "primer."

private aviation. Aviation conducted by individuals, firms, or establishments for their own convenience or benefit not directly (and in many instances not indirectly) for profit.

probe, noun. Specif.: 1. A slender device or apparatus projected into a moving fluid, as for measurement purposes; a pitot tube. 2. A slender projecting pipe on an aircraft which is thrust into a drogue to receive fuel in air refueling. 3. An instrumented research rocket, or its payload, for penetrating the upper atmosphere or beyond.

procedure turn. A timed turn in which an aircraft reverses its heading in accordance with a specified procedure, used when accuracy is required in controlling time or in maintaining a track, as in reversing heading along a radio beam.

proficiency flight. A flight made by a pilot or other aircrew member or members to develop or improve proficiency in flying duties. Cf. CHECK FLIGHT, sense 2.

profile, noun. 1. The contour or form of a body, esp. in section; specif., an AIRFOIL PROFILE. 2. Something likened to a profile (in sense 1), such as a line on a graph. See FLIGHT PROFILE, VELOCITY PROFILE.

profile drag. The sum of an airfoil's friction drag and its form drag which is related to its profile.

profile thickness. The maximum distance between the upper and lower contours of an airfoil profile, measured perpendicularly to the mean line of the profile.

projected area. The area of the shadow of a structure cast by parallel rays of light normal to the surface on which the projection is made. See FRONTAL AREA.

projected diameter. The greatest diameter of an expanded parachute.

—projected effective diameter. The projected diameter of a parachute under a specified load.

projected propeller area. The projected propeller-blade area multiplied by the number of blades of the propeller. See PROJECTED PROPELLER-BLADE AREA.

projected propeller-blade area. The area of the projection of a propeller blade exclusive of the shank (see BLADE, sense 1b), on a plane perpendicular to the axis of rotation of the propeller.

projectile, noun. 1. By extension, any object, esp. a missile, fired, thrown, launched, or otherwise projected in any manner, such as a bullet, a guided rocket missile, a sounding rocket, a pilotless airplane, etc. Cf. sense 2. 2. Originally, an object, such as a bullet or artillery shell, projected by an applied external force.

prop, noun. A clipped form of the word "propeller." Popular.

propellant, noun. That which is expelled from a rocket engine to provide thrust. See ROCKET PROPELLANT.

This term is construed in both singular and plural in the same manner as "rocket propellant."

propeller, noun. 1. An engine-driven screw (see SCREW) mounted, e. g., on an aircraft or vessel, which in its rotation reacts with the surrounding fluid to impart forward motion to the craft; specif., such a screw mounted on an aircraft, not contributing directly to sustentation, and so disting. from a lifting rotor, as on a helicopter. Sometimes called an "air propeller," as disting. from a marine propeller. 2. A fan, esp. a fan in a wind tunnel. Rare. 3. A WINDMILL (in sense 1). Rare.

In sense 1, see ADJUSTIBLE-PITCH PROPELLER, AUTOMATIC PROPELLER, CLUB PROPELLER, CONSTANT-SPEED PROPELLER, CONTRAROTATING PROPELLER, CONTROLLABLE-PITCH PROPELLER, DUCTED PROPELLER, ELECTRIC PROPELLER, FIXED-PITCH PROPELLER, FULL-FEATHERING PROPELLER, HYDROMATIC PROPELLER, PUSHER PROPELLER, REVERSIBLE-PITCH PROPELLER, SINGLE-BLADE PROPELLER, TRACTOR PROPELLER, TURBOPROPELLER, sense 1, VARIABLE-PITCH PROPELLER.

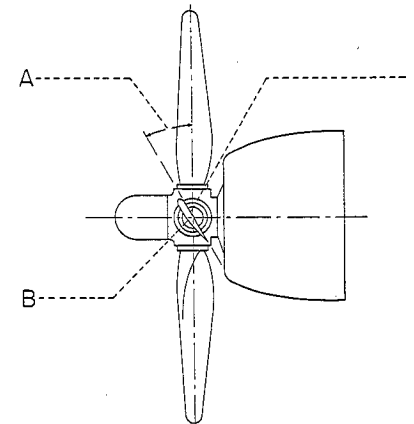

Propeller. A blade angle; B blade back; F blade face.

propeller afterbody. A convex fairing situated immediately behind a propeller, used to improve the airflow. Also called a "dishpan."

propeller blade. A blade or airfoil (see AIRFOIL, sense 1) of a propeller. See BLADE, sense 1.

propeller-blade angle. The blade angle of a propeller blade. See BLADE ANGLE, sense a and note.

propeller cuff. An airfoil-shaped fairing fitted around the shank of a propeller blade (see BLADE SHANK) to increase the flow of air over engine cylinders or into air scoops, etc., or to improve propeller efficiency.

propeller diameter. The diameter (which see) of the circle described by a rotating propeller.

propeller disk. The disk (which see, sense 1) of a rotating propeller.

propeller-driven, adj. Of aircraft: Given thrust by a propeller or by propellers, as in *propeller-driven* fighter.

propeller efficiency. The efficiency with which a propeller converts power input into thrust power, expressed as the ratio of the product of the thrust produced and the forward speed to the power input.

propeller hub. The central portion or part of a propeller, often containing a pitch-changing mechanism, from which the blades radiate and by means of which the propeller is mounted on its drive shaft. See boss.

propeller interference. The interference of the propeller slipstream by a body or bodies placed near the propeller, such as a nacelle, fuselage, radiator, etc., affecting the thrust and torque of the propeller.

propeller-load horsepower. The horsepower required or absorbed by a given propeller at a specified rotational speed. The propeller-load horsepower varies directly as the cube of the rotational speed.

propeller pitch. The pitch of a propeller blade, as disting. from any other pitch. See PITCH, noun, senses 1 and 2.

propeller radius. The radius of a circle described by a rotating propeller. See BLADE RADIUS.

propeller rake. The inclination to a plane perpendicular to the axis of rotation of a line joining the centroids of the sections of a propeller blade; the mean angle of this inclination.

propeller root. That part of a propeller arm nearest the hub—said of all types of propellers. Also called a "blade root" (which see).

propeller slip. The slip (which see, sense 1a) of a rotating propeller, as disting. from any other slip.

propeller slipstream. The SLIPSTREAM (in sense 1).

propeller speed. The speed of a propeller, esp. in revolutions per minute. Cf. TIP SPEED.

propeller thrust. The thrust of a propeller; technically, the component of the total air force on the propeller parallel to, and in the same direction as, the direction of advance. See EFFECTIVE PROPELLER THRUST.

Like aerodynamic lift, propeller thrust may be explained by either or both of two theories, analogous to the theories of lift: See BLADE-ELEMENT THEORY, MOMENTUM THEORY; also see LIFT, THRUST. The so-called primitive theory explains propeller thrust by analogy with the action of an ordinary screw penetrating a solid.

propeller tipping. A protective metal shielding for nonmetallic propellers covering the tip and part of the blade edge.

propeller tip speed. The tip speed of a propeller. See TIP SPEED.

propeller turbine, or propeller-turbine engine. Same as TURBOPROPELLER ENGINE.

propeller wash. The wash (which see) produced aft of a rotating propeller.

propjet engine. Also **propjet, noun.** A turbopropeller engine. See TURBOPROPELLER ENGINE and cf. COMPOSITE POWER PLANT.

proportional control. Radio control of an aircraft, missile, etc. in which control-surface deflection is proportional to the movement of the remote controls. Cf. FLICKER CONTROL.

proportional navigation. The navigation of a guided missile toward a moving target in which the missile turning rate is proportional to the rate of change of the line of sight between missile and target.

propulsive efficiency. The efficiency with which power available for propulsion is converted into thrust, expressed as the ratio of (a) thrust power to shaft power (for propellers) or (b) the ratio of thrust power to the rate of production of kinetic energy in the jet (for jet and rocket engines). See PROPELLER EFFICIENCY.

proving stand. A test stand for reaction engines, esp. rocket engines. See TEST STAND.

pull, verb. 1. *To pull off.* To bring up off the surface, as, to *pull* an airplane off the ground; to break contact with the surface. 2. *To pull out.* To bring out of a dive; to recover from a dive. 3. *To pull up.* To bring the nose of an airplane up sharply, esp. from level flight.

These special senses allude to the pulling action applied to a control stick or column.

pull-out, noun. An act or instance of recovering from a dive. See PULL, sense 2.

pull-up, noun. An act or instance of pulling an airplane's nose up; also, a pull-out. See PULL, sense 3.

pulse altimeter. A radio altimeter that sends out brief surges, or pulses, of radio-frequency energy, the time distance between the transmitted and reflected pulses being used to determine absolute altitude.

pulsejet, noun. A PULSEJET ENGINE.

pulsejet engine. A type of compressorless jet engine in which combustion takes place intermittently, producing thrust by a series of explosions, com-

monly occurring at the approximate resonance frequency of the engine. Often called a "pulsejet."

In the earlier, and commoner, type of pulsejet (as used, e. g., in the German V-1 flying bomb of WW II), air is admitted into the combustion chamber by a set of alternately opening and closing flaps or valves; later types have been designed to operate intermittently without the use of moving parts. (The latter type is sometimes called specifically a "valveless pulsejet.") All types are capable of static operation.

Also called "aeropulse engine," "aeroresonator," "intermittent-jet engine," "resojet," etc. See RESOJET ENGINE.

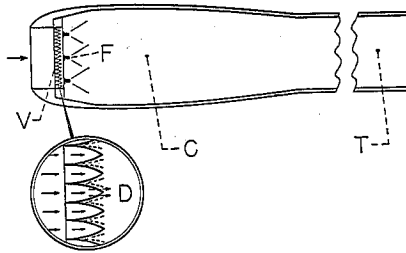

One form of pulsejet engine. (Arrows indicate flow direction.) V flapper valve assembly; F fuel spray nozzles; C combustion chamber; T tailpipe; D detail of valve assembly (dotted lines showing open position).

pursuit airplane. An airplane designed to pursue and attack other aircraft—the former designation for a fighter, or fighter airplane.

push-down, noun. An act or instance of nosing an airplane down. Also called a "push-over."

pusher, noun. 1. A PUSHER AIRPLANE. 2. A PUSHER PROPELLER.

pusher airplane. An airplane with its propeller or propellers aft of the center of gravity or lateral axis.

pusher engine. An engine fitted with a pusher propeller. Cf. TRACTOR ENGINE.

pusher propeller. A propeller mounted aft of an engine; a propeller mounted behind the lateral axis or center of gravity of an aircraft. Cf. TRACTOR PROPELLER.

push-over, noun. Same as PUSH-DOWN.

pylon, noun. 1. a. A structure, strut, or post supporting an engine pod, an external tank, etc. on an aircraft. b. A ROTOR MAST. 2. A post or towerlike structure used as a course marker or as a ground reference for precision maneuvers. See COURSE MARKER. Cf. MAST.

pylon eight. An eight on pylons. See EIGHT, note.

quadrant, noun. Specif.: 1. Any one of the four signal zones in a four-course radio range. See LOOP-TYPE RADIO RANGE. 2. A CONTROL QUADRANT.

quadrantal error. An error in the indication of a radio compass or magnetic compass owing to the distortion or re-radiation of the radio waves or magnetic lines of force by the body of the airplane.

With a radio compass, the quadrantal error is at a maximum when the incoming radio waves cross the wings or horizontal tail at a relative bearing between the airplane and the station of 45°, 135°, 225°, or 315°.

racer, noun. Specif., an aircraft, esp. an airplane, specially designed or modified for racing; an aircraft used for racing.

rack, noun. Specif., a LAUNCHING RACK.

racon, noun. [From "radar beacon."]

Same as RADAR BEACON.

radar, noun. [From "radio-detection and ranging."] 1. A method, system, or technique of using beamed, reflected, and timed radio waves for detecting, locating, or tracking objects (such as airborne aircraft), for measuring altitude, etc., in any of various activities, such as air traffic control, guidance, or gunnery. 2. The electronic equipment or apparatus used to generate, transmit, receive, and, usually, to display radio scanning or locating waves; a RADAR SET.

radar altimeter. A RADIO ALTIMETER.

radar beacon. A kind of beacon (which see) consisting of a radar transmitter and other associated equipment that sends out radar waves for pickup and display on a radar set, giving indications of the beacon's range, bearing, or, usually, both range and bearing, from the radar set. Also called a "racon."

A radar beacon normally transmits signals only when activated by a pulse from a radar set. Such a beacon is often called a transponder (which see). Some types of radar beacons, however, emit signals continuously, not requiring triggering action.

Radar beacons are employed in air navigation and have numerous military uses, as in bombing, and identification of friend or foe.

radar horizon. The angle of elevation at which the beams from a radar ap-

quadricycle landing gear. A landing gear consisting of four separate wheels or wheel units.

quadriplane, noun. A form of airplane, now obsolete, having quadruple-decked wings.

quartering wind. A wind moving in a direction that makes an angle of approximately 45° with the longitudinal axis of an aircraft.

quick-release harness. A parachute harness which allows all straps binding the parachute to the wearer to be released by the action of one unlocking device.

R

paratus are intercepted by the earth's horizon.

radar indicator. A RADARSCOPE.

radar range. The maximum distance at which a radar set is effective in detecting targets.

Radar range depends upon variables such as weather conditions, type of target, etc. "Radar range" is sometimes given a specific definition, e. g., the range at which the set is effective one half of the time.

radar scan. 1. The searching motion of a radar beam through space in any of various path configurations; the pattern of a radar beam's motion. 2. RADAR SCANNING.

radar scanning. The action or process of moving or directing a searching radar beam.

See CIRCULAR SCANNING, CONICAL SCANNING, HELICAL SCANNING.

radarscope, noun. The cathode-ray tube or oscilloscope in a radar set, which displays the received signal in such a manner as to indicate range, bearing, etc. Sometimes called a "radar indicator."

radar screen. 1. The face of a radarscope. 2. A network of radar installations, or their emanations, serving, e. g., to detect strange aircraft.

radar set. A set of electronic apparatus consisting principally of a transmitter, antenna, receiver, and indicator for sending out scanning beams and receiving and displaying the reflected waves or the waves emitted by a radar beacon. See RADAR.

radar wave. A transmitted or reflected radio wave used in radar.

radial, noun. 1. A RADIAL ENGINE. 2. Something that extends radially, such as any one of the bearing lines radiating from an omnidirectional radio range.

radial compressor. Same as RADIAL-FLOW COMPRESSOR.

radial engine. An internal-combustion reciprocating engine having its cylinders disposed radially around the crankshaft; specif., such an engine with which the cylinders remain stationary while the crankshaft rotates and which has five or more cylinders to a row (the row being in a plane perpendicular to the crankshaft). Cf. ROTARY ENGINE.

The term "radial engine" is not applied to such engines as the opposed-cylinder engine or V-engine, nor is it customarily applied to engines such as the X-engine, Y-engine, etc.

radial-flow compressor. A rotary compressor through which the compressible fluid is accelerated radially. See CENTRIFUGAL COMPRESSOR.

radiator, noun. 1. A device that radiates energy, such as electromagnetic energy. 2. A device that dissipates the heat from something, as from water or oil, not necessarily by radiation only.

Generally, the application of the terms "radiator" (in sense 2) or "heat exchanger" to a particular apparatus depends upon the point of view: If the emphasis is upon merely getting rid of heat, "radiator" is most often used, or sometimes "cooler"; if the emphasis is upon transferring heat, "heat exchanger" is used—but these distinctions do not always hold true.

radio aid. Any navigation aid utilizing radio, such as a radio beacon, radio compass, etc.

radio altimeter. An absolute altimeter that measures altitude by measuring the lapsed time between the transmission of radio waves from an aircraft and the reception of the waves reflected from the earth's surface. See PULSE ALTIMETER.

radio beacon. Any radio transmitter, together with its associated equipment, that emits signals enabling the determination, by means of suitable receiving equipment, of direction, distance, or position with respect to the beacon. See EQUISIGNAL BEACON, LOCALIZER, LOCATION MARKER, RADIO-RANGE BEACON.

radio beam. A beam (which see, sense 3) of radio signals, as in an equisignal zone.

radio compass. A direction-indicating radio-receiving apparatus used aboard aircraft, which makes use of the directional characteristics of a loop antenna for finding and indicating direction in relation to a radio-transmitting station to which the receiver is tuned.

Radio compasses exist in several different forms, some types employing fixed loop antennas, and other more elaborate and useful types using antennas rotatable either manually or automatically. Radio compasses are used in homing on a transmitting station and in obtaining bearings and fixes.

radio control. 1. Remote control of a pilotless airplane, a rocket, etc., by means of radio signals that activate controlling devices. 2. Any radio apparatus used for this kind of control. 3. The control of aircraft or air traffic by means of radio communication.

radio direction-finder. A radio-receiving set, together with its associated equipment, used to determine the direction from which a radio signal is transmitted.

"Radio direction-finder" is a broad term, applied to radio compasses and other airborne or ground-based radio-receiving sets or stations in direction-finding systems. See AUTOMATIC DIRECTION FINDER.

radio direction-finding system. A system in which radio is used to determine position or bearing; specif., a system in which two or more ground stations are used to establish fixes on aircraft transmissions, the resulting position information being transmitted to the aircraft.

radio-frequency heating. The heating of electrically conducting material by means of electric currents induced by electromagnetic waves of radio frequency.

radio magnetic indicator. A radio-navigation instrument coupled with a gyrosyn compass or the like that indicates magnetic heading and bearing with respect to a transmitting station.

radio marker. A LOCATION MARKER.

radiometeorograph, noun. An instrument or apparatus that senses meteorological phenomena, such as temperature, pressure, etc., and transmits by radio the values of these phenomena to a receiving station for automatic recording; a radiosonde.

radio navigation. Navigation by means of radio aids or navigation systems using radio, as by the radio compass, radio direction-finding systems, loran, etc. See HYPERBOLIC NAVIGATION.

radio range. 1. A radio transmitting station or installation that sends out directional radio beams for the guidance of aircraft throughout a comparatively large area. 2. The signals and electronically defined flight paths emanating from such a directional transmitting station; the area covered by these directional signals.

See ADCOCK RADIO RANGE, LOOP-TYPE RADIO RANGE, OMNIDIRECTIONAL RADIO RANGE, VISUAL-AURAL RADIO RANGE.

3. The distance to which a radio transmitter can send effectively. 4. The span of radio frequencies in the electromagnetic spectrum.

radio-range beacon. The central radio beacon in a radio range, which sends out directional beams or signals.

radiosonde, noun. An airborne radiometeorograph. See DROPSONDE, RADIO-METEOROGRAPH.

radius, noun. 1. The maximum distance out from its point of departure that an aircraft can fly without landing and return to its departure point under the given or specified conditions. 2. a. BLADE RADIUS. b. LEADING-EDGE RADIUS.

In sense 1, sometimes called radius of action (esp. of military aircraft) or radius of operation. See CRUISING RADIUS and cf. RANGE, sense 1a.

radome, noun. [From "radar dome."] Pronounced "raydome." A dome housing for a radar antenna and sometimes its associated equipment on an aircraft, the dome material being pervious to radio waves.

rain loop. A continuous strip of fabric attached to an airship envelope around the car to deflect water.

rake, noun. 1. A device consisting essentially of a row of pressure-measuring tubes or temperature sensitive elements arranged like a rake or comb, used to sense the pressure or temperature at desired intervals in a fluid flow. Also called a "comb" (which see). 2. Inclination from a straight line or plane; the amount of this inclination. See PROPELLER RAKE, WING-TIP RAKE.

ram, noun. 1. The action of air or other fluid shoving its way into an air intake or open duct owing to the motion of the intake or duct through the fluid; RAM

EFFECT OR RAM PRESSURE. 2. A scoop, intake, duct or the like that receives ram air.

ram air. Air shoved into an air intake or open duct by the motion of the intake or duct through the air.

ram drag. The drag on a jet engine due to the change of momentum of the incoming air, equal to the product of the rate of mass flow at the air intake and the free-air velocity.

ram effect. The effect resulting from ram (which see, sense 1); RAM PRESSURE.

ramjet, noun. A RAMJET ENGINE.

ramjet engine. A type of compressorless jet engine consisting of a specially shaped tube or duct open at both ends, the air necessary for combustion being shoved into the duct by the forward motion of the engine, where the air passes through a diffuser and is mixed with fuel and burned, the exhaust gases issuing in a jet from the rear opening. The ramjet engine cannot operate under static conditions. Often called a "ramjet."

See ATHODYD, ROCKET RAMJET, TURBORAMJET ENGINE, TWO-DIMENSIONAL RAMJET.



Ramjet engine (supersonic type). (Arrows indicate flow direction.) H flame holders.

ramp, noun. 1. An inclined structure, works, or surface, e. g.: a. A compression surface ahead of an air intake. b. A works or platform sloping into the water for beaching or launching seaplanes. c. An inclined framework for launching rockets or pilotless airplanes off the ground. 2. Loosely, any paved or otherwise prepared area around the hangars or flight line of an airdrome; an apron.

ram pressure. The pressure in excess of atmospheric or ambient pressure owing to ram (which see, sense 1).

ram pressure recovery, or ram recovery. The recovery or conversion of velocity pressure in the free-air stream to static pressure at some point in a duct receiving ram air; the amount of static pressure produced in this process.

range, noun. Specif.: 1. a. The maximum distance from its departure point to which an aircraft can fly without

landing under the given or specified conditions. The range of any given aircraft depends upon the load carried, flight altitude, flight speed, atmospheric conditions, the possibility of air refueling, etc. Cf. RADIUS. b. The maximum distance to which a rocket, a missile, etc. may be projected or flown under the given conditions. 2. a. The capability of an aircraft, rocket, etc. as measured or judged by the maximum distance it can fly or be projected; this capability regarded figuratively as reach, as, a plane with long range. b. A good or excellent capability of this nature, as, an aircraft that has both range and endurance. 3. A row of landmarks used in maintaining a straight course. 4. The distance that a radio or radar transmitter can cover. See RADAR RANGE, RADIO RANGE, SENSE 3. 5. A RADIO RANGE (in senses 1 or 2).

rate climb. A climb at a constant rate.
rated, adj. Of airspeed, altitude, horsepower, etc.: Designated as the best or maximum for safe and efficient operation.

rated engine speed. The rotative speed of an engine specified as the maximum for continuous reliable performance.

rate descent. A descent at a constant rate.

rated horsepower. The maximum horsepower an engine can develop under specified operating conditions.

See MILITARY RATED POWER, NORMAL RATED POWER, TAKE-OFF HORSEPOWER, WAR EMERGENCY POWER.

rate gyroscope. A gyroscope sensitive to the rate of angular motion.

rate of climb. The rate at which an aircraft gains altitude, i. e., the vertical component of its airspeed in climbing.

rate-of-climb indicator. A flight instrument that indicates the rate of climb or rate of descent of an aircraft in any convenient units, e. g., feet per minute. Also called a "climb indicator" or "vertical-speed indicator."

rate of descent. The rate at which an aircraft descends, i. e., the vertical component of its airspeed in descending; the rate at which a parachute and its burden descend.

rate-of-turn indicator. A TURN INDICATOR.

ratiometer, noun. Specif., an instrument or device sensitive to the ratio between two electric currents, used,

e. g., in temperature-measuring instruments.

RATO, Rato, or rato, noun. [From "rocket-assisted take-off."] 1. A take-off in which a rocket or rockets, commonly of the solid-fuel type, are used to provide additional thrust. Hence, RATO bottle, Rato bottle, rato unit, etc., a rocket so used. 2. A RATO bottle or unit; the complete apparatus on an aircraft, comprising rockets, ignition system, etc., for assisted take-off.

See JATO

RAWIN, Rawin, or rawin, noun. [From "radar wind" or "radio wind." Pronounced "raywin."] 1. The action of observing or determining wind direction and speed by radio or radar tracking of a balloon carrying a radiosonde, a radar reflector, or a radio transmitter. 2. Wind, the direction and speed of which is determined by radio or radar tracking of a specially equipped balloon; the wind information gathered in this manner.

rawinsonde, noun. A radiosonde used to find wind direction and speed. See RAWIN, SENSE 1.

reaction balance. A type of thrust meter using a balance to measure the static thrust of a rocket or jet engine.

reaction engine, or reaction motor. An engine or motor that develops thrust by its reaction to a substance ejected from it; specif., such an engine that ejects a jet or stream of gases created by the burning of fuel within the engine. A reaction engine operates in accordance with Newton's third law of motion, i. e., to every action (force) there is an equal and opposite reaction. Rocket engines and jet engines are reaction engines. See JET ENGINE, ROCKET ENGINE.

reaction propulsion. Propulsion by reaction to a jet or jets ejected from one or more reaction engines.

reaction turbine. A type of turbine having rotor blades shaped such that they form a ring of nozzles, the turbine being rotated by the reaction of the fluid ejected from between the blades. Cf. IMPULSE TURBINE.

reactor, noun. Specif., a NUCLEAR REACTOR.

read, verb tr. To hear clearly or understand (a radio station or a person speaking by radio). *Colloq.*

rear, adj. Specif., at, near, or belonging to the hind part of an aircraft, as in rear cockpit, rear fuselage, rear gunner.

Rebecca-Eureka system. A radar homing system for aircraft in which an airborne interrogator-responder, called "Rebecca," homes on a ground radar beacon, called "Eureka." The system is used, e. g., by pathfinders.

rebreather bag. A bag attached to an oxygen mask which captures the exhaled gas from the upper part of the respiratory system, consisting primarily of unused oxygen, for breathing again.

receding blade. Same as RETREATING BLADE. *Rare.*

receiver aircraft. The aircraft that receives fuel in air refueling.

reciprocal, adj. Of a bearing, heading, etc.: Opposite in direction to, and colinear with, another bearing, heading, etc.

reciprocating engine. An engine (which see) esp. an internal-combustion engine, in which a piston or pistons moving back and forth work upon a crankshaft or other device to create rotational movement.

Reciprocating engines of the internal-combustion type are classified according to: a. Arrangement or disposition of cylinders, as barrel, fan, H-, in-line, inverted, opposed-cylinder, radial, V-, W-, X-, and Y-engine. b. Method of ignition, as compression-ignition and spark-ignition engine. c. The manner in which the working gases act upon the piston or pistons, as double-acting, opposed-piston, and single-acting engine. d. The piston strokes per engine cycle, as four-stroke-cycle and two-stroke-cycle engine. e. Some special mechanical feature, as cam engine. f. The conditions specified for rated operation, as altitude and sea-level engine. (See individual entries on various types.) Also see COMPOUND ENGINE.

reciprocating-type supercharger. A supercharger that utilizes one or more pistons for compression. This is a positive-displacement supercharger.

recompression, noun. 1. The act or process of subjecting to, or undergoing, an increase in air or atmospheric pressure after a decompression. 2. The act or process of compressing air or other fluid again.

reconnaissance aircraft. Aircraft, or an aircraft, designed, modified, or used for reconnaissance.

recording, adj. Of an instrument: That makes a record of its measurements, as in recording accelerometer, record-

ing altimeter (see ALTIGRAPH), recording dynamometer, etc.

recovery, noun. 1. In flying, the action of an aircraft returning, or being restored, to the initial attitude after a spin, dive, loop, roll, etc. 2. A reclaiming. See RAM PRESSURE RECOVERY, WATER RECOVERY.

red-out, noun. A temporary condition in which vision is obscured by a reddishness, or in which objects appear to have a reddish color. This condition, sometimes followed by unconsciousness (not considered a part of the red-out), is caused by blood rushing to the head. Cf. BLACKOUT, SENSE 1.

reduced frequency. The frequency of vibration of a body, or of the variation of the flow behind the body, expressed as the circular frequency times the representative length of the body divided by the velocity of the flow.

reduction gear. A set of gears by means of which the rotational speed of a driven shaft is reduced from that of the drive shaft, as between an engine shaft and a propeller shaft.

reef, verb tr. To constrain (a parachute), as by a metal ring about its shroud lines, so that it opens only partially; to open (a parachute) in stages.

reentry, noun. Specif., an act or instance of a rocket, an airplane, etc., having risen above the earth's atmosphere, or above the denser portion of the atmosphere, penetrating the atmosphere or its denser portion in its downward plunge.

In compounds, such as reentry heating, reentry slowdown, an act or instance of a projectile's slowing down, or of slowing it down, upon reentry.

reference area. Specif., any characteristic area of a body used in defining an aerodynamic or hydrodynamic force coefficient.

reflected wave. 1. A shock wave, expansion wave, or compression wave reflected by another wave incident upon a wall or other boundary. 2. *Electronics.* A radio wave reflected from a surface or object.

reflection plane. In wind-tunnel testing, a plane surface or plate, corresponding to a plane of symmetry, upon which a split, or semispan, model is mounted. The plane produces results comparable with the results that would have been obtained with the complete model, thus

allowing models of a larger scale to be accommodated in the tunnel.

reflexed trailing edge. A curled trailing edge; technically, the trailing edge of an airfoil in which the curvature of the mean camber line changes sign near the trailing edge. Also called a **reflex trailing edge**.

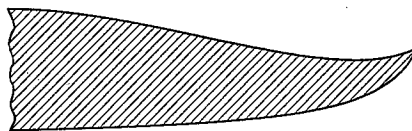

Reflexed trailing edge.

regenerative cooling. The cooling of a part of an engine by the fuel or propellant before burning; specif., the cooling of a rocket-engine combustion chamber or nozzle by circulating the fuel or oxidant, or both, around the part to be cooled.

regenerator, noun. A device used in a thermodynamic process for capturing and returning to the process heat that would otherwise be lost, as a device in a gas-turbine engine for transferring heat from the exhaust to the air entering the combustion chamber. Also called a "heat exchanger" (which see).

reheat, noun. REHEATING (esp. in sense 1).

reheating, noun. 1. The adding of heat to a working fluid in an engine after a partial expansion. Afterburning is a form of reheating. 2. The retention of heat in a fluid, as after passing through a turbine stage, owing to the inefficiency of the stage.

relative bearing. The bearing of a point or object relative to the heading of an aircraft or vessel.

relative density. A density relative to another density; specif., the actual density of the air relative to the density under standard conditions, expressed as a ratio. See DENSITY RATIO.

relative humidity. Humidity expressed as the ratio of the amount of water vapor present in the atmosphere to the greatest amount possible under the prevailing conditions, usually expressed in percent.

relative pressure. A pressure relative to another pressure; specif., the actual atmospheric pressure relative to the standard atmospheric pressure, expressed as a ratio.

relative wind. Air in motion with respect to a body in it; the velocity or direction of air in motion with respect to a body, usually of the air outside the region affected by the body, i. e., the free stream.

The relative wind may arise from the motion of the body, from the motion of the air, or from both the motion of the body and of the air.

relaxation time. In general, the time required for a system, object, or fluid to recover to a specified condition or value after disturbance.

remote control. Control from a distance, esp. by means of electricity or electronics; a controlling switch, lever, or other device used in this kind of control.

In compounds, "remote control" properly takes the hyphen, as in remote-control armament, remote-control switch, etc., but in common usage the hyphen is just as often omitted, as in remote control system.

remote-indicating, adj. Of an instrument: Displaying indications at a point remote from its sensing element, often by electrical or electromagnetic means.

remote velocity. The velocity of the free stream—disting. from the LOCAL VELOCITY.

renversement, noun. [French; un-Anglicized pronunciation.] Same as REVERSEMENT.

repeater, noun. An indicator that reproduces at a remote point the indications of another indicator. Also called a repeater indicator.

Repeaters are used for the remote reproduction of the indications of a compass, of a plan-position indicator, etc.

reporting point. A geographic location in relation to which the position of an aircraft is reported, or is to be reported.

reserve, noun. FUEL RESERVE.

reserve buoyancy. Same as EXCESS BUOYANCY.

residual gas. Specif., the gas remaining in the cylinder of an engine immediately after the closing of the exhaust valve or valves.

resistance, noun. The act or an instance of resisting, of opposing; specif., AIR RESISTANCE.

resistance derivative. A STABILITY DERIVATIVE.

resojet engine. Also **resojet, noun, or resonant jet.** A pulsejet engine that operates at its resonance frequency. Also called an "aeroresonator."

responder, noun. 1. A TRANSPONDER. 2. The receiver unit in a transponder.

retractable aileron. An aileron that retracts into the wing: specif., a retractable spoiler used as an aileron. See SPOILER and note.

retractable landing gear. A landing gear that may be retracted into or up against the aircraft in flight, to reduce drag.

retreating blade. On a rotary-wing aircraft in horizontal motion, a rotor blade or wing moving with the relative wind. With a rotary-wing aircraft in forward motion, the blade is considered retreating as it moves 180° from its extreme forward position to its extreme aft position. Cf. ADVANCING BLADE.

retrofit, noun. [From "retroactive fit."] A modification of an aircraft, aircraft component, or other object that duplicates a change or modification made in later models of the same type.

—retrofit, verb tr., as, to retrofit an aircraft with a tricycle landing gear.

retro-rocket, noun. [From "retroacting."] A rocket fitted on or in an aircraft, missile, or the like that produces thrust to retard forward motion.

return-flow wind tunnel. Same as CLOSED-CIRCUIT WIND TUNNEL.

rev, noun. 1. A revolution (of an engine, a rotor, etc.). Colloq. 2. In plural. Revolutions per minute. Colloq.

rev, verb tr. Usually, to rev up. To increase the rotary speed of. Also intr. Colloq.

reversal, noun. 1. An act or instance of moving or acting in an opposite direction. See AILERON REVERSAL, CONTROL-FORCE REVERSAL. 2. Specif.: a. A change in the deflection of a control surface from one direction to the opposite direction. b. A change in the direction of a flow from the original to the opposite direction.

reversed flow. Specif., flow from the trailing edge to the leading edge of a rotor blade, as occurs esp. over the inboard portion of a retreating blade.

reverse-flow combustion chamber. A form of burner used in early aircraft gas-turbine engines, in which air from the compressor travels the full length of the chamber then has its direction of flow reversed to enter the flame tube or inner liner, the exhaust gases issuing from the chamber near the end where the compressor air is introduced. Also

called a "counterflow burner." See REVERSE-FLOW ENGINE and cf. STRAIGHT-FLOW COMBUSTION CHAMBER.

reverse-flow engine. An early type of gas-turbine engine for aircraft in which the air from the compressor is introduced into a special form of burner where its direction of flow is reversed before combustion. This design resulted in an engine of short length, but its disadvantages of low power and efficiency caused its discontinuance.

—reverse-flow gas-turbine engine, reverse-flow turbojet engine. See REVERSE-FLOW COMBUSTION CHAMBER.

reversement, noun. Any maneuver or stunt in which an airplane is made to reverse its direction of flight, as a chandelle, an Immelmann turn, or wing-over. Also called a "renversement." See VERTICAL REVERSEMENT.

reverse-pitch propeller. Same as REVERSIBLE-PITCH PROPELLER.

reverse thrust. The thrust, or a large component of the thrust, of a propeller or jet directed opposite to the usual direction, providing braking action. Sometimes called "negative thrust."

Propellers are turned to a negative pitch to direct the air blast forward; defectors or other devices are used to direct the thrust of jets forward.

reversible, adj. Of a process: Capable of going through its stages in reverse order.

reversible-pitch propeller. A propeller whose pitch may be changed to a negative angle so as to give reverse thrust, used for braking action. Also called a "reverse-pitch propeller."

reversible propeller. An ambiguous term for "reversible-pitch propeller."

revolving beacon. Same as ROTATING BEACON.

Reynolds number. [After Osborne Reynolds (1842-1912), English scientist.] A nondimensional parameter representing the ratio of the momentum forces to the viscous forces about a body in a fluid flow. It is often expressed as the

fraction $\frac{\rho V l}{\mu}$, where ρ is the density of the fluid, V is its velocity, l is a characteristic dimension of the body, and μ is the coefficient of viscosity of the fluid.

See CRITICAL REYNOLDS NUMBER, EFFECTIVE REYNOLDS NUMBER.

rho-theta system. Any electronic navigation system in which position is defined in terms of distance, or radius (ρ) and bearing (θ) with respect to a transmitting station. Also called an "R-theta system."

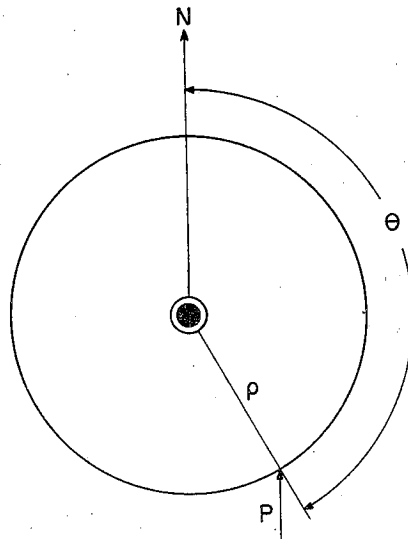

Illustrating principle of a rho-theta system. P located point.

rhumb line. A line of constant direction that intersects all meridians at the same angle. A rhumb line appears as a straight line on a Mercator projection.

rhumb-line course. A course laid out or taken along a rhumb line.

rib, noun. Specif., a chordwise structural member, usually a former, in a wing or other airfoil.

See BOX RIB, BUTT RIB, COMPRESSION RIB, FALSE RIB.

ribbon parachute. A type of parachute having a canopy consisting of an arrangement of closely spaced tapes. This parachute has high porosity with attendant stability and slight opening shock.

rich, adj. Of a combustible mixture: Having a relatively high proportion of fuel to air or oxidant; more precisely, having a value greater than stoichiometric.

rich blowout. A blowout or flameout caused by a too-rich fuel-air mixture. See BLOWOUT, FLAMEOUT.

rig, verb tr. 1. To attach, adjust, and align (the parts, gear, or other apparatus of an aircraft), as, to rig a flap, to rig a car to an airship envelope, or, to rig a cable into a truss. 2. To fit out (an aircraft) with control cables, bracing wires, control surfaces, or other apparatus or gear. 3. To assemble, inspect, repair, adjust, and pack (a parachute or its harness).

rigger, noun. One who rigs aircraft or parachutes. See PARACHUTE RIGGER.

rigging, noun. 1. The action of the verb rig; the result of this action, as, uneven rigging. 2. The system of cables, wires, fittings, etc. with which an aircraft is rigged. 3. The shroud lines of a parachute.

right, noun. 1. Specif., the right side of an aircraft. See RIGHT, *adj.* 2. The area or direction to one's right-hand side, as, a slip to the right.

See STARBOARD, *noun.*

right, adj. Specif., situated on, or directed toward, the right-hand side of a person at the longitudinal axis of an aircraft and facing forward, as in right slip, right wing; coming from the right, as in right wind. See STARBOARD, *adj.*

right-hand engine. An engine whose crankshaft or other main shaft rotates in a clockwise direction, as seen from the antipropeller end of the engine. See LEFT-HAND ENGINE, *note.*

rigid, noun. A rigid airship.

rigid airship. An airship whose form is maintained by a rigid framework.

The last rigid airship, the LZ-130, a sister ship to the Hindenburg, was completed in Germany in 1938. It was disassembled in 1940, having been test-flown but never having been put into service. See AIRSHIP and *note*, ZEPPELIN.

rigid rotor. A nonarticulated and non-tilting rotor. See ARTICULATED ROTOR, TILTING ROTOR.

rime, noun, or rime ice. An opaque white ice of granular structure, less dense than glaze.

ring airfoil. Same as ANNULAR AIRFOIL.

ring cowling. A narrow, ring-shaped cowling for a radial engine, designed to reduce drag and improve cooling.

ringworm, noun. A circular crack in a doped surface.

rip cord. Also, less often, ripcord, *noun.* 1. A cord, cable, or the like, together with its handle and fastening pins,

holding a parachute pack closed and which when pulled free opens the pack and allows the parachute to deploy. 2. A cord, rope, or other line, together with its hand pull and other appurtenances, for opening the rip panel on a balloon or airship.

In compounds, this term is written either "rip-cord" or "ripcord," as in rip-cord handle, ripcord pin, etc.

rip panel. A strip of fabric or other material in a balloon or pressure airship, which may be torn or ripped open for quick deflation.

riser, noun. Something that rises, i. e., that extends upward, as: a. A lift web of a parachute assembly. See LIFT WEB. b. A tube from a pitot or static line sticking up into a pressure chamber in a certain type of pitot-static tube. See PITOT-STATIC TUBE (*illus.*).

roadable airplane. An airplane, either fixed-wing or rotary-wing, capable by means of some ready conversion of being used as a road vehicle.

This term is applied esp. to vehicles that fold their wings or blades for road travel. See CONVERTIBLE and cf. FLYING AUTOMOBILE and *note*.

robomb, noun. [From "robot bomb."] Same as ROBOT BOMB.

robot, noun. An automatic or self-acting apparatus or mechanism that performs actions ordinarily done by man; a vehicle or machine operated by such apparatus.

This term is applied esp. to pilotless aircraft; it is seldom applied to rocket missiles or the like, whether self-guided or guided remotely.

robot bomb. A self-propelled, winged bomb that automatically keeps on course and descends on its target—applied particularly to the German V-1 winged jet bomb of WW II or to a bomb of that type. Sometimes called a "robomb."

rock, verb tr. 1. To tilt (an airplane's wings) from side to side. 2. To pitch (a seaplane or flying boat) while moving on the water, esp. so as to expedite the get-away.

rocket, noun. 1. A projectile, pyrotechnic device, or flying vehicle propelled by a rocket engine or motor. See ROCKET ENGINE. 2. a. A rocket engine or motor. b. Any one of the combustion chambers or tubes of a multi-chambered rocket engine.

rocket airplane. An airplane using a rocket or rockets for its chief or only propulsion.

rocket-assisted take-off. The full term for "RATO" (in sense 1, which see).

rocket booster. A BOOSTER, senses 2 and 3.

rocket engine, or rocket motor. A jet-reaction engine or motor (see REACTION ENGINE) that contains within itself, or carries along with itself, all the substances necessary for its operation or for the consumption or combustion of its fuel, not requiring intake of any outside substance and hence capable of operation in outer space. Chemical-rocket engines contain or carry along their own fuel and oxidant, usually in either liquid or solid form, and range from simple motors consisting only of a combustion chamber and exhaust nozzle to engines of some complexity incorporating, in addition, fuel and oxygen lines, pumps, cooling systems, etc., and sometimes having two or more combustion chambers. Experimental rocket motors have used gaseous propellants. Rocket motors are chiefly employed to propel pyrotechnic devices, missiles, aircraft, and other flying vehicles, and are also used extensively as auxiliary thrust units on aircraft. See RATO. See also LIQUID-PROPELLANT ROCKET ENGINE, SOLID-PROPELLANT ROCKET ENGINE, and also see ROCKET PROPELLANT.

There is noted a tendency to employ the term "rocket engine" in reference to the relatively complicated liquid-propellant types and to use "rocket motor" as a general term embracing both liquid-propellant and solid-propellant types; no sharp distinction between the terms has been observed, however. See ROCKET, sense 2a.

rocket nozzle. The exhaust nozzle of a rocket. See JET NOZZLE.

rocket propellant. a. Any agent used for consumption or combustion in a rocket and from which the rocket derives its thrust, such as a fuel, oxidant, additive, catalyst, or any compound or mixture of these; specif., a fuel, oxidant, or a combination or mixture of fuel and oxidant used in propelling a rocket. b. Also rocket propellants. All of the individual agents, esp. fuel and oxidant, taken collectively, used in a rocket for its propulsion.

Rocket propellants are commonly in either liquid or solid form. See BI-PROPELLANT, DOUBLE-BASE PROPELLANT, HYPERGOLIC PRO-

PELLANTS, LIQUID PROPELLANT, MONOPROPELLANT, MULTIPROPELLANT, SOLID PROPELLANT. "Rocket propellant," is often shortened to "propellant."

rocket-propelled, adj. Propelled solely by a rocket or rockets, as in *rocket-propelled* missile. See JET PROPELLED.

rocket propulsion. Propulsion by a rocket or rockets. It is a type of reaction propulsion. See REACTION PROPULSION.

rocket ramjet. A ramjet engine having a rocket mounted within the ramjet duct, the rocket being used to bring the ramjet up to the necessary operating speed. Sometimes called (with a shift in emphasis) a "ducted rocket."

rocketry, noun. The science or study of rockets, including theory, research, development, experimentation, and application; the art or science of using rockets.

roll, noun. 1. a. The act of rolling; the rotational or oscillatory movement of an aircraft or similar body which takes place about a longitudinal axis through the body—called "roll" for any degree of such rotation. b. The amount of this movement, i. e., the ANGLE OF ROLL. 2. A stunt, maneuver, or performance in which an aircraft is caused to make a complete rotation (of 360°) about its roll axis, usually maintaining an approximately horizontal direction of flight. See note. 3. The movement, travel, or run of a wheeled aircraft on the ground or other surface in take-off or landing, i. e., a *landing roll* or *take-off roll*. (See individual entries.)

In sense 2, see BARREL ROLL, HALF-ROLL, OUTSIDE ROLL, SLOW ROLL, SNAP ROLL.

roll, verb. 1. *tr.* To rotate (an aircraft or similar body) about a longitudinal axis. 2. *tr.* To put (an aircraft) into a roll (in sense 2). 3. *intr.* Of an aircraft, etc.: a. To rotate about a longitudinal axis. b. To make a roll (in sense 2)—also said of persons in an aircraft.

roll axis. A longitudinal axis through an aircraft, missile, or similar body, about which the body rolls. It may be a body, wind, or stability axis, or any other lengthwise axis. See AXIS, sense 2 and note.

rolling axis. Same as ROLL AXIS.

rolling moment. A moment that tends to rotate an aircraft, a rocket, etc. about a longitudinal axis. This moment is

considered positive when it tends to depress the starboard side of the body.

roll-off, noun. An uncontrolled rolling motion of an airplane resulting from stalling.

roll-out, noun. 1. An act or instance of making a landing roll. 2. An act or instance of recovering from a banked attitude. 3. The first showing of a prototype.

root, noun. Specif., the base or inner end of an airfoil or blade. See BLADE ROOT, WING ROOT.

root diameter. Specif., the diameter of the rotor of an axial-flow compressor at any given stage or of a turbine wheel, measured between the points of juncture of the blades with the disk or hub. Cf. TIP DIAMETER.

root rib. Same as BUTT RIB.

Roots-type supercharger. A positive-displacement supercharger consisting of two intermeshing double-lobed impellers (dumbbell-shaped in section) turning on parallel shafts within a housing with small clearances. The type is used mainly on stationary and automotive engines.

rotary engine. 1. An engine incorporating a gas turbine or other rotating element as its principal part. 2. An obsolete kind of aircraft engine in which the crankshaft or its equivalent remains stationary while the cylinders rotate around it—usually a radial type of engine, but sometimes a barrel type. See BARREL ENGINE, RADIAL ENGINE.

rotary induction system. An induction system for radial engines in which a fan assists in distributing the fuel-air mixture to the individual cylinders.

rotary-wing, adj. 1. Of or pertaining to rotary-wing aircraft, or to rotating and sustaining airfoils, as in *rotary-wing* aerodynamics; performed in or with rotary-wing aircraft, as in *rotary-wing* flight. 2. Deriving lift from rotating airfoils, as in *rotary-wing* glider, or, an aircraft that is *rotary-wing*.

rotary-wing aircraft. A type of aircraft which in all its usual flight attitudes is supported in the air wholly or in part by wings or blades rotating about a substantially vertical axis. Also *collective*, as, ten *rotary-wing* aircraft.

"Rotary-wing aircraft" embraces the autogyro, gyrodyne, gyroplane, and helicopter; the convertiplane is a hybrid. (See individual entries on these craft.) Cf. ROTORCRAFT.

rotate, verb tr. To rotate the courses.

To move the courses of a four-course radio range in azimuth without changing their angular relationship. Cf. SQUEEZE.

rotating beacon. A light beacon that rotates about a vertical axis. Airport beacons and airway beacons are rotating beacons. Also called a "revolving beacon."

rotating-beam ceilometer. A type of ceilometer in which a light projector is rotated in the vertical plane of a detector fixed to receive from the zenith. The intensity of the reflected light received by the detector changes from zero to maximum to zero again as the projector rotates, with the projector elevation angle that corresponds to the maximum of light received by the detector depending on the height of the cloud base and the cloud structure.

rotating stall. A species of blade stall or compressor stall in which the stall condition shifts in the plane of rotation from one group of blades to another.

rotating wing. An airfoil that rotates in a substantially horizontal plane.

rotating-wing aircraft. Same as ROTARY-WING AIRCRAFT.

rotational flow. Flow in which the individual small fluid elements rotate about their own axes.

rotachute, noun. [*Rotor* + *parachute*]. A device or apparatus consisting essentially of a set of freely rotating blades, used as a parachute to lower a burden slowly from altitude, the blades being turned by the air in the descent.

rotor, noun. A part or assembly that rotates or spins, such as the armature in an electric motor, the wheel in a gyroscope, an antitorque screw on a helicopter, etc.; specif.: a. An assembly of airfoils, together with a hub, hinges, etc., that rotates about a substantially vertical axis to provide lift and thrust or lift only for a helicopter, an autogyro, or the like. b. A turbine wheel or the rotating component of a compressor.

The term "rotor" is not applied to a propeller.

See ANTI TORQUE ROTOR, ARTICULATED ROTOR, CONTRAROTATING ROTOR, CONTROL ROTOR, JET ROTOR, RIGID ROTOR, SEMIRIGID ROTOR, TAIL ROTOR, TILTING ROTOR.

rotor angle of attack. The angle of attack of a rotor, expressed as the angle

between a rotor disk and the relative wind. Positive when the leading edge of the rotor disk is elevated with respect to the trailing edge. See ANGLE OF ATTACK, sense 1.

rotor axis. An axis of rotation or a reference axis through a rotor.

See AXIS OF NO FEATHERING, AXIS OF NO FLAPPING, AXIS OF ROTATION, CONTROL AXIS.

rotor blade. 1. A blade or airfoil (see AIRFOIL, sense 1) of the rotor of a rotary-wing aircraft. See BLADE, sense 1. 2. A blade or vane of the rotor in an axial compressor or of a turbine wheel.

rotor-blade angle. The blade angle of a rotor blade. See BLADE ANGLE, sense b and note.

rotor-blade radius. The radius of a rotor blade. See BLADE RADIUS.

rotor-blade root. 1. That part of a rotary wing nearest the hub; the inboard end of a rotary wing, joined to the bar or arm that attaches the blade to the hub. 2. That part of an axial-flow compressor rotor blade or of a turbine rotor blade nearest the disk or hub; that part of a compressor or turbine blade imbedded in the disk or hub.

See BLADE ROOT.

rotorcraft, noun. An aircraft which in all its usual flight attitudes is supported in the air wholly or in part by a rotor or rotors, i. e., by airfoils rotating or revolving about an axis. Also *collective*, as, five *rotorcraft*. A rotorcraft is also called a "rotor plane."

The term "rotorcraft" (or "rotor plane") is commonly applied to a helicopter, autogyro, or the like, in which the sustaining airfoils rotate about a substantially vertical axis; it is also applied to aircraft such as the cyclogiro (which see). Cf. ROTARY-WING AIRCRAFT.

rotor diameter. The diameter (which see) of the circle described by a rotating rotor.

rotor disk. 1. The disk (which see, sense 1) of the rotating rotor of a helicopter, autogyro, or the like. 2. Any one of the flat circular plates that constitute the rotor of an axial-flow compressor, to which the blades are attached; also, the hub of a turbine wheel.

rotor head. A rotor hub assembly, including that part of the control system mounted on the rotor hub. See ROTOR HUB.

rotor hub. Specif., the central part or portion, usually an assembly, in a rotary-wing system, to which the blades are attached and by means of which the rotor is mounted on the drive shaft. See HUB.

rotor inflow. The inflow (which see) of a rotor, esp. as disting. from any other inflow.

rotor lift. The lift component, parallel to the plane of symmetry and perpendicular to the line of flight, acting on a rotor. See ROTOR THRUST.

rotor mast. A column or structure supporting a rotor on a rotary-wing aircraft. Usually called simply a "mast" or "pylon."

rotor plane. A ROTORCRAFT.

rotor slipstream. The stream of air driven downward by a powered rotor. *Rare.* See DOWNWASH.

rotor speed. The speed of a rotary-wing system, of a compressor rotor, or of any other rotative component, esp. in revolutions per minute. Cf. PERIPHERAL SPEED, TIP SPEED.

rotor system. 1. The system or assembly of airfoils, hinges, attaching shafts, hub, etc. comprising a rotor. 2. The system or assemblage comprising all the rotors on a rotorcraft.

This is ordinarily a general term, but where specifically defined it may be taken to include, where applicable, the rotor or rotors, the drive shaft, the tail rotor and its drive shaft, the freewheel device, control linkages, etc.

rotor thrust. The force component exerted by a rotor along the axis of rotation or other chosen axis.

With a helicopter, the rotor thrust provides both sustentation and propulsion.

rotor tip speed. The tip speed of a rotor, esp. a rotary-wing system. See TIP SPEED.

round-out, noun. A flare-out, esp. that part of the flare-out near the surface.

route, noun. A way traveled, or to be traveled; an AIR ROUTE.

route forecast. A weather forecast of conditions to prevail along a route.

rpm, or r. p. m.—Abbreviation for *revolutions per minute*—often used in the sense of "rotational speed" (in revolutions per minute), and so in this sense construed as a singular noun, as, a given rpm, or, an rpm that is constant.

R-theta system. Same as RHO-THETA SYSTEM.

rudder, noun. 1. An upright control surface that is deflected to impress a yawing moment, i. e., to make the aircraft or other body of which it is a part rotate about its vertical axis; a movable jet vane, as on a rocket. See DRAG RUDDER. 2. The movement or deflection of a rudder, as, to apply full left rudder. 3. A rudder bar or rudder pedal, as, to move the stick and rudder simultaneously. 4. A WATER RUDDER. 5. Either a vertical or horizontal control surface. *Obs.*

—left rudder, right rudder. Rudder deflection with the trailing edge to left or right, respectively.

This word occurs in numerous compounds (mostly self-explanatory), some of which are: rudder axis, rudder buffeting, rudder control, rudder control wheel (on certain ships), rudder fillet, rudder-force reversal (see CONTROL-FORCE REVERSAL), rudder-free motion (motion with the rudder not under the restraint of the controls), rudder horn (see CONTROL HORN), rudder position indicator, rudder reversal (see REVERSAL, sense 2a), rudder trim tab.

rudder angle. The acute angle between the rudder and the plane of symmetry of an aircraft, or between the rudder and the plane of the fin. This angle is considered positive when the trailing edge of the rudder is to the port side of the aircraft.

rudder bar. In some airplanes, a pivoted, foot-operated bar for operating a rudder or other directional-control device.

rudder booster. A control booster for a rudder. See CONTROL BOOSTER.

rudder lock. 1. An airplane control condition in which the rudder maintains a full deflection if left free, requiring a right rudder force to return the rudder to neutral in a right sideslip and vice versa. 2. A control lock for a rudder or rudder control. See CONTROL LOCK.

rudder pedal. Either one of a pair of cockpit pedals for operating a rudder, an antitorque rotor, or other directional-control device.

rudderpost, noun. 1. The post or top-to-bottom member at the leading edge of a rudder. 2. A hinge post through a rudder. 3. A post at the rear of a vertical fin, to which the rudder is attached. See STERNPOST, sense 3.

ruddervator, noun. [*Rudder* + *elevator*.] Also *ruddevator*. A control surface, set at a pronounced dihedral,

that serves both as a rudder and as an elevator. Also called an "elerudder."

Ruddervators are used, e. g., in the butterfly tail on an airplane, in the dihedral tail surfaces on an airship, and on the "flying boom" aerial refueling tube.

rumble, noun. 1. A form of combustion instability, esp. in a liquid-propellant rocket engine, characterized by a low-pitched, low-frequency rumbling noise; the noise made in this kind of combustion. 2. A low-pitched, rumbling noise of combustion in an internal-combustion piston engine, distinct from knock, accompanied by rough operation.

run, noun. Specif., a LANDING RUN or a TAKE-OFF RUN.

run, verb tr. *To run up.* To operate (an aircraft engine) at a relatively high rotational speed while the aircraft remains standing, in order to test or warm the engine or to examine it for proper operation. Cf. WARM.

runner, noun. A kind of slide, other than a ski, used in the main landing gear of certain airplanes, esp. early airplanes; a skid.

running fix. A fix determined by intersecting lines of position obtained at dif-

ferent times and resolved to a common time.

running gear. The landing gear of an airplane. *Obs.*

running light. Same as NAVIGATION LIGHT.

running take-off. 1. A take-off by a helicopter or similar craft in which a run is required to become airborne. 2. A take-off made immediately after touching down, before coming to a stop. See TOUCH-AND-GO LANDING.

run-up, noun. An act or instance of running an engine up. See RUN, *verb*.

runway, noun. A long and narrow prepared strip or piece of ground, usually hard-surfaced, for the take-off and landing of airplanes.

The term "runway" is rarely applied to the flight deck of an aircraft carrier. The term is applied to water areas or strips only in a general sense, as, the natural *runway* provided by a river. See WATER LANE.

runway contact light. Same as RUNWAY LIGHT.

runway light. Any one of a line of lights along either side of a runway to mark its location at night. Sometimes called a "contact light."

runway localizer. Same as LOCALIZER.

rupture disk. Same as BURST DISK.

S

sabot, noun. [French, "wooden shoe." Commonest pronunciation "sa-bo," the *a* as in "about" and accent on the last syllable.] A device fitted around or in

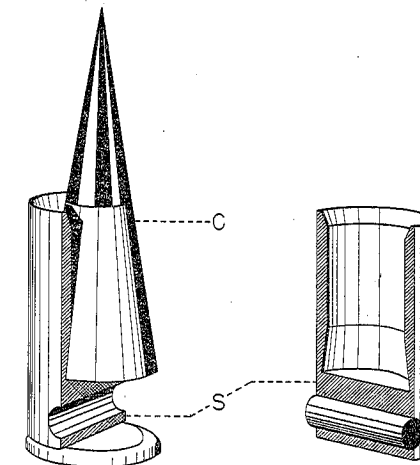

One kind of sabot S; C projectile cone.

back of a projectile in a gun barrel or launching tube to support or protect the projectile or to prevent the escape of gas ahead of it.

The sabot is used, e. g., with gun-launched free-flight models, and separates from the projectile after launching.

SAE number. Specif., any of a series of numbers established as standard by the Society of Automotive Engineers for grading lubricating oils according to viscosity, beginning with 10 for the lightest oil and expressed in multiples of ten for heavier oils. The SAE number is roughly one half of the Saybolt number. See SAYBOLT NUMBER.

safety, verb tr. To secure against loosening or rotating, as, to *safety* a bolt by passing a restraining wire through its head.

—safetied, *adj.*, *safetying, noun.*

safety belt. A restraining belt used in an aircraft or other vehicle, which is fastened about a person's body to pre-

vent being thrown about under sudden or abnormal accelerations, as in crash landing or violent maneuvering. See LAP BELT, SHOULDER HARNESS.

safety pilot. 1. A pilot who accompanies a student pilot or a pilot practicing hooded flight to warn of danger or to take over the controls if need be. Cf. CHASE PILOT. 2. A pilot who rides in a remotely controlled or automatically controlled aircraft or vehicle to fly it in the event of control failure.

sag, verb intr. Of an airship or flying boat: To bend downward in the middle, the ends pointing upward. Cf. HOG.

—*sag, noun*, as, the *sag* of the airship.

sail, verb intr. To soar, or to glide and soar; to pass smoothly through the air.

sailplane, noun. A glider having a high glide ratio, designed for soaring. It is typically characterized by very clean lines and a wing of high aspect ratio.

Cf. GLIDER, and see PERFORMANCE-TYPE GLIDER, SECONDARY GLIDER.

sandwich, adj. Of sandwich construction, as in *sandwich* panel, *sandwich* skin, etc. See SANDWICH CONSTRUCTION.

sandwich construction. A type of construction in which two sheets, sides, or plates are separated by a core of stiffening material, generally lightweight, such as balsa wood. See HONEYCOMB SANDWICH CONSTRUCTION.

saturation, noun. *Meteorol.* The condition of a body of air holding the most water vapor it can at the prevailing temperature.

sausage balloon. A kite balloon resembling a sausage. *Slang.*

sawtooth climb. Any one of a series of climbs made at different airspeeds or angles of attack between given pressure altitudes to determine the speed or angle giving the maximum rate of climb at a given altitude, the trace of such a series of climbs, as recorded by a barograph, making a zigzag line resembling sawteeth.

Saybolt number. [After George M. Saybolt (1853-1924), American scientist.] A number expressing the viscosity of an oil in the seconds (Saybolt universal seconds) required for 60 cc of the oil at a given temperature to flow through a standard orifice, the tem-

peratures usually being 130° F. for lighter oils and 210° F. for heavier oils. See SAE NUMBER.

scale effect. Any variation in the nature of the flow and in the force coefficients associated with a change in value of the Reynolds number, i. e., caused by change in size without change in shape.

scale error. An error in the indication of an instrument owing to incorrect calibration or to maladjustment.

scale model. A model of a different size from its prototype and having dimensions in some constant ratio to the dimensions of the prototype, esp. such a model of smaller size than its prototype.

scanner, noun. A radar mechanism incorporating a rotatable antenna, or radiator, motor drives, mounting, etc. for directing a searching radar beam through space and imparting target information to an indicator.

scanning, noun. RADAR SCANNING.

scavenge pump. A pump in a dry-sump lubricating system that removes used oil from the sump and returns it to the supply tank. Also called a *scavenger pump* or *scavenging pump*.

schlieren, noun. [German, "streaks," "striae."] Specif.: 1. Regions of different density in a fluid, esp. as shown by special apparatus. 2. A method or apparatus for visualizing or photographing regions of varying density in a field of flow. See SCHLIEREN PHOTOGRAPHY.

Used in compounds, such as *schlieren* lens, *schlieren* method, *schlieren* photograph, etc.

schlieren photography. A method of photography for flow patterns that takes advantage of the fact that light passing through a density gradient in a gas is deflected as though it were passing through a prism.

scissors, noun. A set of torque arms. *Slang.* See TORQUE ARMS.

scissors range. A radio range with squeezed courses. See SQUEEZE.

scoop, noun. Specif., an AIR SCOOP.

scoop pressure. The air pressure from an air scoop, measured as the static absolute pressure at the exit of the scoop and after the screen when a screen is present.

scope, noun. A clipped form of the word "oscilloscope" or "radarscope."

screaming, noun. A form of combustion instability, esp. in a liquid-propellant

rocket engine, occurring at relatively high frequencies and characterized by a high-pitched noise; the noise made in this kind of combustion.

screeching, noun. A form of combustion instability, esp. in an afterburner, occurring at relatively high frequencies and characterized by a harsh, shrill noise; the noise made in this kind of combustion; screaming.

screw, noun. A device or contrivance consisting essentially of a hub with (usually) two or more radiating blades twisted or inclined so that each blade, as it rotates with the hub and moves in the direction of its axis of rotation, describes a helical path, and being likened to a segment of a common screw. Most screws are engine-driven and are used to propel ships, aircraft, etc. (*screw propeller*); a wind-driven screw is usually called a "windmill" (which see, sense 1). The term *screw* is also applied to helicopter rotors and tail rotors, chiefly in the combination *airscrew* (which see, sense 1 and note). See PROPELLER.

scroll, noun, or scroll collector. On some centrifugal compressors, a spiral casing or passage of diverging aperture around the diffuser, which collects the compressed fluid from the diffuser and discharges it through one or more outlets.

sealed internal balance. An internal balance in which a flexible curtain or partition connects the nose of the control-surface overhang with the wall of its chamber in the fixed airfoil. The seal assists in utilizing air forces to deflect the control surface in the desired direction. See INTERNAL BALANCE.

sea level. As used in most aeronautical contexts, the mean, or standard, sea level, which has a pressure of 29.92 in., or 760 mm., of mercury at 15° C. (59° F.). See STANDARD ATMOSPHERE and note, STANDARD DATUM PLANE.

This term is often used attributively in compounds designating conditions at mean sea level, the power or output of an engine at mean sea level, etc., as in *sea-level* atmospheric pressure, *sea-level* brake torque, *sea-level* density, *sea-level* thrust, etc.

sea-level engine. A supercharged engine having its maximum rated power output at sea level and intended esp. for

use at low altitudes. Cf. ALTITUDE ENGINE.

seaplane, noun. An airplane, commonly a floatplane or a flying boat, designed to take off and alight on water only—disting. esp. from a LANDEPLANE; specif., a FLOATPLANE—disting. from a FLYING BOAT.

seaplane base. A base or airdrome for seaplanes, either military, naval, or civil, comprising water lanes, taxi channels, anchorage areas, shore facilities, etc.

seaplane float. A float (which see) on a seaplane, esp. a main float of a floatplane, as disting. from a stabilizing float of either a floatplane or flying boat.

seaplane hull. The main body of a flying boat, which floats the craft upon the water. Also called a "flying-boat hull."

search radar. Radar apparatus or a radar set designed for locating aircraft or other objects, as disting. from radar used for any other purpose.

seat, noun. Specif., a place to sit in an airplane or the chair in which one sits in an airplane.

Used in compound attributive adjectives, such as *two-seat*, *six-seat*, etc., designating aircraft with seats for two people, six people, etc., the figure usually including the seat or seats for the pilot or crew; the term "multi-seat" has no currency. See PLACE and note, SEATER and note.

seat belt. Same as LAP BELT.

seater, noun. Specif., a word used only in combination, as in *single-seater*, *two-seater*, etc. (i. e., an aircraft providing a seat for one person, one with seats for two persons, etc., including pilot or crew).

Combinations including "seater" are also used as attributive adjectives, as in *two-seater* glider. See SEAT and note.

seat-pack parachute. A parachute or parachute pack worn at the rump.

seat-to-head acceleration. *Av. med.* 1. Accelerating force acting on the body in the direction from the seat to the head, as occurs, e. g., when seated in an airplane pulling out of a dive. Sometimes called "positive acceleration" (which see). 2. An inertial force acting in the direction from the seat to the head. *Rare.* See ACCELERATION, sense 3 and final note.

sea wing. A short, broad structure or surface, roughly wing-shaped, projecting from either side of a flying-boat

hull near the bottom to provide lateral stability on the water. Also called a "sponson" or "stub wing." (See individual entries on these terms.)

secant ogive. An ogive whose circular-arc contours have their centers on a line aft of the normal to the axis at the base of the ogive, therefore forming a corner where the ogive joins the cylindrical body behind it. See *ogive* (illus.).

secondary air. Air introduced at a point downstream of the combustion section of a turbojet engine or the like to lower the temperature of the combustion gases—disting. from PRIMARY AIR.

secondary glider. A glider or sailplane of a type more or less intermediate between the primary glider and the performance-type glider, ruggedly built and adapted both to student glider training and to soaring.

second pilot. A COPILOT (esp. in sense 1).
section drag. Same as PROFILE DRAG.

Rare.

seeding, noun. The action of strewing condensation nuclei, such as crystals of dry ice or silver iodide, over or through a cloud so as to induce precipitation or to clear a cloud cover.

seesawing, noun. The rocking motion of a tilting rotor. See TILTING ROTOR.

selector valve. A valve used to direct the flow of a fluid to a particular mechanism, as in a hydraulic system; a valve by means of which fluid is drawn from a particular tank. See FUEL SELECTOR.

self-guided missile. A missile that is not remotely controlled but instead guides itself along its course by self-contained devices, such as preset devices or homing devices.

self-sealing, adj. Of a fuel tank, a coupling, etc.: Capable of covering or closing small ruptures in itself, as by means of a lining substance.

self-synchronous motor. Same as SYNCHRONOUS MOTOR.

selsyn, noun. [A trade name, from "self-synchronous"; often capitalized.]
1. An electrical remote-indicating instrument operating on direct current, in which the angular position of the transmitter shaft, carrying a contact arm moving on a resistance strip, controls the pointer on the indicator dial. Used as a position indicator, etc. 2.

Incorrectly, an autosyn or similar electrical apparatus.

semiactive homing. The homing (which see) of a guided missile wherein the missile seeks its target utilizing energy waves transmitted from a point outside of the target and outside the missile and reflected from the target. The transmission of energy waves may be from the missile launching station or from a point external to the launching station.

semicantilever, adj. Of a beam or member: Supported in part by external bracing but having most of the load carried by the structure of the member, as in *semicantilever* wing. Cf. FULL-CANTILEVER.

semimonocoque, noun. 1. A type of construction, as of a fuselage or nacelle, in which longitudinal members, as well as formers, reinforce the skin and help carry the stresses. 2. Something incorporating such construction, such as a wing. Cf. MONOCOQUE, *noun*.

semimonocoque, adj. Built as a semimonocoque or embodying the principles of the semimonocoque, as in *semimonocoque* construction, *semimonocoque* fuselage.

semirigid, noun. A SEMIRIGID AIRSHIP.

semirigid airship. An airship that maintains its form by means of a rigid or flexible keel in conjunction with internal pressure in the gas compartments and ballonets. The type has not been built in recent years. See AIRSHIP and note.

semirigid rotor. 1. A partly articulated rotor, esp. a rotor with blades free to flap but not to drag. 2. A TILTING ROTOR.

semispan, noun. One half the span of an airfoil or airplane. See SPAN.

sense indicator. An aircraft radio indicator that shows whether the aircraft is flying toward or away from an omnirange station. Sometimes called a "to-from indicator."

sensitive altimeter. A kind of aneroid altimeter constructed so as to respond to pressure changes with a high degree of sensitivity and having two or more pointers indicating altitude in different divisions of measurement (hundreds of feet, thousands of feet, etc.).

separated flow. Flow over or about a body that has broken away from the

surface of the body and no longer follows its contours.

separation, noun. 1. FLOW SEPARATION.

2. The spacing of airborne aircraft laterally, longitudinally, or vertically.

separation point. The point on the surface of a body at which flow separation occurs. See FLOW SEPARATION.

sequence valve. An automatic valve in a hydraulic system that causes one hydraulic action to follow another in a definite order.

service ceiling. The height above sea level, under standard air conditions, at which a given airplane or rotary-wing aircraft is unable to climb faster than a specified rate.

service tank. A fuel tank near an engine from which the fuel is drawn for the engine, the fuel being drawn into this tank from a supply tank.

service test. A test, as of an aircraft or engine, under service conditions or conditions simulating those expected to be encountered in service.

—service-test, *verb tr.*, as, to *service-test* an engine.

servo, noun. Short for "servomechanism," "servomotor," etc.

servo, adj. Of or pertaining to a servo control, a servomechanism, etc., as in *servo* action, *servo* amplifier, *servo* piston, etc.; accomplished by means of a servomechanism, as in *servo* stabilization.

servo control. 1. a. A controlling device or apparatus incorporating a servomechanism. b. A control apparatus incorporating a booster, such as a hydraulic control booster or a servo tab. 2. Control utilizing a servomechanism or a control booster.

Also spelled *servocontrol*, esp. in sense 1.

servo control tab. Same as SERVO TAB.

Rare.

servo flap. A servo tab, esp. a servo tab on a rotor blade. See SERVO TAB and TAB, note.

servomechanism, noun. 1. A mechanism in which the output quantity, such as angular position, rotational speed, voltage, etc., is monitored and compared with a desired quantity, the difference between the two quantities (the error) being used to actuate the system and to generate a rate of change of the output.

An example of a servomechanism is the automatic-pilot apparatus comprising a gyro unit, air relay, oil valve, hydraulic control-actuating mechanism, follow-up device, etc., in which the follow-up, connecting the hydraulic piston with the gyro unit, operates so as to cause the correct degree and rate of control to be applied.

A mere power-boost device, although incorporating what is sometimes called a "servomotor," a "servo tab," etc., is not ordinarily called a "servomechanism."

2. *Specif.*, as defined by the American Institute of Electrical Engineers, a device such as described in sense 1 in which the controlled variable is mechanical position.

servomotor, noun. 1. A motor in a servomechanism. 2. A motor that supplements a primary control force; a booster motor. See CONTROL BOOSTER.

servo rotor. A rotor for controlling a main rotor. See CONTROL ROTOR.

servo tab, or servotab, noun. A tab (which see) directly actuated by the aircraft control system and which, when deflected, causes the control surface or other surface to which it is attached to be deflected or moved by the air forces acting on the tab. Sometimes called a "Flettner tab" or "flying tab." See SERVO FLAP, SPRING TAB.

sesquiplane, noun. A biplane in which one of the wings is one half, or less than one half, the area of the other wing.

set, verb tr. To set (an aircraft) down. To land an aircraft. Also *intr.* of an aircraft or persons within.

settling chamber. A chamber, as in a wind tunnel or pitot-static tube, in which the moving fluid is brought substantially to rest so as to reduce the turbulence of the fluid.

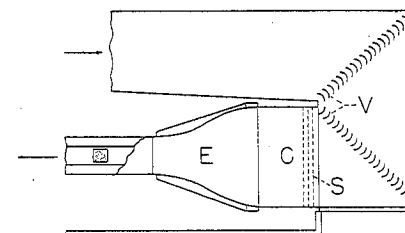

Settling chamber in a wind tunnel. (Arrows indicate flow direction.) C settling chamber; V vanes; S screens; E entrance cone.

shadowgraph, noun. 1. A picture or image in which steep density gradients in the flow about a body are made visible, the body itself being presented in silhouette. 2. The optical method or technique by which this is done.

shaft horsepower. The horsepower delivered by an output shaft. This is a brake horsepower, but "shaft horsepower" appears to be a preferred term where there is reduction gearing between the output shaft and the main shaft of the engine.

shallow, adj. Making an angle with the horizontal of only a few degrees, as in *shallow* climb, *shallow* glide, *shallow* turn (a turn with the wings only slightly banked).

shank, noun. Specif., a **BLADE SHANK**.
sharp-edged gust. A theoretical gust with a velocity gradient distance approaching zero, used in mathematical computations of the effect of actual gusts.

shed, noun. Specif., an airship shed. See **AIRSHIP HANGAR**.

shielding, noun. Specif., the action of enclosing electrical or radio equipment in conduits, boxes, etc. so as to prevent electrical interference; the material or coverings used in this.

shimmy damper. Any of various devices attached to a castoring wheel to damp oscillation about the castoring axis.

ship, noun. Specif.: 1. Any aircraft. *Colloq.* 2. An **AIRSHIP**.

shock, noun. Short for **SHOCK WAVE**.

shock cord. A strong, many-stranded rubber cord encased in a braided fabric sheath, used, e. g., as a shock absorber on certain lightplanes or as a launching device for gliders.

shock drag. Same as **WAVE DRAG**.

shock front. 1. A shock wave regarded as the forward surface of a fluid region having characteristics different from those of the region ahead of the wave. 2. The front side of a shock wave.

shock mount. A shock-absorbing mount for a sensitive apparatus, as for an instrument panel.

—*shock-mount, verb tr.*, as, to *shock-mount* an instrument.

shock-stall, noun, or shock stall. A stall brought on by compressibility burble, i. e., by separation of flow aft of a shock wave.

shock strut. A shock-absorbing landing-gear strut. See **AIR-OIL SHOCK STRUT**, **OLEO**.

shock tube. A relatively long tube or pipe in which very brief high-speed gas flows are made to occur by the sudden release of gas at a very high pressure into the low-pressure portion of the tube, the high-speed flow as it moves into the region of low pressure being preceded by a shock wave. The shock tube is used as a tool in the study of gases or as a kind of intermittent wind tunnel.

shock wave. A surface or sheet of discontinuity (i. e., of abrupt changes in conditions) set up in a supersonic field of flow, through which the fluid undergoes a finite decrease in velocity accompanied by a marked increase in pressure, density, temperature, and entropy, as occurs, e. g., in a supersonic flow about a body. Sometimes called a "shock."

See **ATTACHED SHOCK WAVE**, **BOW WAVE**, **SENSE 1**, **CONDENSATION SHOCK WAVE**, **DETACHED SHOCK WAVE**, **MACH WAVE**, **NORMAL SHOCK WAVE**, **OBLIQUE SHOCK WAVE**.

shoot, noun. The action of firing a rocket from the earth's surface; an instance of this, as, to attend a *shoot*. *Popular*. Cf. **SHOT**, sense 1.

shoot, verb tr. To shoot a landing. To make a practice landing. *Popular*.

shoran, noun. [From "short range navigation"; sometimes capitalized.] An electronic position-finding system in which a pulse transmitter triggers responses from two transponders of known location, the elapsed time between transmittal of a triggering signal and the reception of a response from each transponder establishing a fix.

short take-off and landing. The full term for "STOL" (which see).

shot, noun. 1. An act or instance of firing a rocket, esp. from the earth's surface, as, the *shot* carried the rocket 200 miles. Cf. **SHOOT**. 2. The flight of a rocket, as, the rocket made a 200-mile *shot*; the action of a rocket engine firing.

shoulder harness. A harness that fastens over a person's shoulders to prevent his being thrown forward in his seat. See **LAP BELT**.

shoulder-wing monoplane. A monoplane whose wing halves are mounted just below the top of the fuselage.

shroud, noun. 1. A hood, casing, covering, or enclosure of some kind, such as a circular covering for several flame tubes in a jet engine, a case for a compressor, etc. See **SHROUD RING**. 2. A **SHROUD LINE**, as, to pull on the *shrouds*.

shroud line. In a parachute, any one of a number of lines that attach the harness or load to the canopy. Also called a "shroud" or "suspension line."

shroud ring. A ring-shaped shroud; esp., a band around the periphery of a turbine wheel, used to strengthen the blades.

side car. A car, usually a power car, suspended or attached off the center line of an airship. Also called a "wing car." See **POWER CAR**.

side float. A stabilizing float at the side of a floatplane or flying boat. See **STABILIZING FLOAT**.

side-skid, verb. To skid. See **SKID, verb**.

sideslip, noun. 1. A movement of an aircraft such that the relative wind has a velocity component along the lateral axis. See **ANGLE OF SIDESLIP**. 2. Specif.: a. A sidewise movement of an aircraft to one side or the other of the projected initial flight path—disting. from a **FORWARD SLIP**; a sidewise movement of a parachute in descent. b. In a turn, a sidewise movement toward the inside of the turn—disting. from a **SKID**.

sideslip, verb. 1. *intr.* Of an aircraft or persons within: To move in a sideslip. 2. *intr.* Of a parachutist: To move to the side of the direction of descent. 3. *tr.* To put (an aircraft) into a sideslip.

sideslip angle. Same as **ANGLE OF SIDESLIP**.

sideslipping, noun. The action of the verb *sideslip*.

sidewash, noun. A flow deflected laterally by a body.

sidewash angle. The acute angle in the horizontal plane between the sidewash from a body and the line of the undisturbed airstream. This angle is positive when the sidewash deflection is to port.

signal flare. A pyrotechnic flare of distinctive color and characteristics, used for signaling.

silk, noun. A synecdoche for "parachute" (in allusion to the material of which formerly made) in the phrase

"to hit the silk," i. e., to parachute out. *Slang*.

simple flap. Same as **PLAIN FLAP**.

simulated altitude. A set of air conditions maintained within a room or chamber that duplicates certain of the conditions, commonly pressure and temperature, that usually occur at some given altitude. See **ALTITUDE CHAMBER**.

simulated flight. An exercise or set of conditions that simulates that occurring in actual flight. See **FLIGHT SIMULATOR**.

simulator, noun. A device, such as a Link trainer, an electronic apparatus, etc., that simulates flight or some other condition in one way or another, used, e. g., in exercises or problem solving. See **FLIGHT SIMULATOR**.

single-acting engine. A reciprocating engine in which the gas or other working substance acts on one end of the piston only. This is the usual form of internal-combustion reciprocating engine.

single-blade propeller. A propeller, chiefly experimental, having only one blade, counterbalanced opposite its root.

single-engine, or, less often, single-engined, adj. 1. Of aircraft: Having only one engine, esp. a reciprocating engine. See **ENGINE**, note, **TWIN-ENGINE**, and cf. **SINGLE-JET**. 2. Achieved or performed by or in a single-engine aircraft, as in *single-engine* ceiling, *single-engine* flight. 3. Of a pilot: Trained, experienced, or qualified to fly single-engine aircraft.

single-entry compressor. A centrifugal compressor that takes in air or fluid on only one side of the impeller, the impeller being faced with vanes only on that side.

single-float seaplane. A seaplane supported on the water by one central float, stabilized on water by smaller outboard floats.

single-jet, adj. Having only one jet engine, as in *single-jet* fighter.

single-stage compressor. A centrifugal compressor having a single impeller wheel, with vanes either on one or on both sides of the wheel; also, an axial-flow compressor with one row of rotor blades and one row of stator blades. Axial-flow compressors are normally multistage.

single-stage rocket. A rocket propelled by or comprising a single rocket motor which may have several chambers.

single-stage turbine. A turbine having one set of stator blades followed by a set of rotor blades.

sink, noun. 1. In the mathematical representation of fluid flow, a hypothetical point or place at which the fluid is absorbed. 2. A HEAT SINK.

sink, verb intr. To descend; to descend in a glide.

sinking speed. The rate at which an aircraft loses altitude; esp., the rate at which a heavier-than-air aircraft descends in a glide in still air under given conditions of equilibrium.

skag, noun. A vertical plate or member serving as a continuation of the keel behind the main step on a float or hull, esp. on a float, installed to protect the bottom.

skewed aileron. An aileron having a hinge axis that passes through points not at a constant percent of the chord length of the wing from the leading edge—usually so called only when the hinge axis cuts across the chords at a rather pronounced slant.

skid, noun. 1. A sidewise movement of an aircraft toward the outside of its turn—disting. from a sideslip (in sense 2b, which see). 2. A runner or slide used in the landing gear of certain aircraft. See LANDING SKID, TAIL SKID, WING SKID.

skid, verb intr. To make a skid (in sense 1.)

—skidding, *noun.*

skin, noun. The covering of a body, of whatever material, such as the covering of a fuselage, of a wing, of a hull, of an entire aircraft, etc.; a body shell, as of a monocoque fuselage; the surface of a body.

skin friction. The friction (which see) of a fluid against the skin of an aircraft or other body; FRICTION DRAG.

skin-friction drag. Viscous drag over the skin of a body; FRICTION DRAG.

skin temperature. The outer-surface temperature of a body.

skip, verb intr. Of a seaplane or flying boat: To skim along the surface of the water, alternately touching the water and rising slightly into the air.

skiplane, noun. An airplane fitted with skis in place of wheels or other gear,

for taking off and landing on ice or snow.

skirt, noun. Specif., the peripheral border of a parachute canopy.

sky cover. The cover of the sky by cloud; the extent of cloud cover in the sky. See OVERCAST.

sky diving. The action of making a delayed-release parachute jump or jumps for sport.

Skyhook, noun. [Originally a code name for a US Navy project.] A large free balloon having a plastic envelope, used esp. for meteorological soundings.

skyrocket, noun. A fireworks rocket that is fired into the sky, there sometimes to explode in a burst of fireballs. It is commonly made with a heavy paper combustion chamber and a long stabilizing stick.

skywriting, noun. The act of forming letters or other figures in the sky with the visible trail, as of smoke, of an aircraft.

—skywriter, *noun.*

slab tail. Same as ALL-MOVABLE TAIL.

slant range. The distance between two points not at the same height, as between a ground observer and an airborne aircraft.

slat, noun. Any of certain long, narrow vanes or auxiliary airfoils, used, e. g., in a venetian-blind flap; specif., the vane used in an automatic slot.

slave station. In a hyperbolic navigation system, a station whose transmissions are controlled by a master station. See HYPERBOLIC NAVIGATION and cf. MASTER STATION.

sleeve, noun. Specif., a tubular article of fabric or other material suggesting a shirt sleeve. See INFLATION SLEEVE, TOW TARGET, note.

slinger ring. A device at the hub of a propeller from which de-icing or anti-icing fluid is thrown out along the blades by centrifugal force.

slip, noun. Specif.: 1. a. The action of a propeller sliding or slipping in the helical path indicated by its geometric pitch (in effect, contracting that helix along the line of advance), owing to the yielding nature of the air, such an action being expressed as the difference between the geometric pitch and the effective pitch of the propeller and stated either as a percentage of geometric pitch or as a linear dimension. b. The elastic yielding action of a fluid

acted upon by a blade, vane, compressor, etc., esp. by the impeller of a centrifugal compressor, thus incurring losses wherein the theoretical work is not achieved. See SLIP COEFFICIENT.

2. A sidewise movement of an aircraft in flight. See FORWARD SLIP, SIDESLIP.

slip, verb intr. and tr. To make, or to put into, a slip (in sense 2); specif., to sideslip. See SIDESLIP, verb.

—slipping, *noun.*

slip coefficient. A coefficient expressing the slip of a centrifugal compressor, expressed as the ratio of tangential fluid velocity to the impeller tip velocity.

slip flow. Flow about a body in which the fluid directly next to the surface of the body is in motion with respect to the body, slipping over it, as occurs when the mean free path of the fluid molecules is of approximately the same magnitude as the thickness of the boundary layer.

slip function. A function of propeller slip, expressed as the ratio of the speed of advance through the undisturbed air to the product of the rpm and the propeller diameter, i. e., V/nD , where V is the speed of advance, n is the rpm, and D is the diameter.

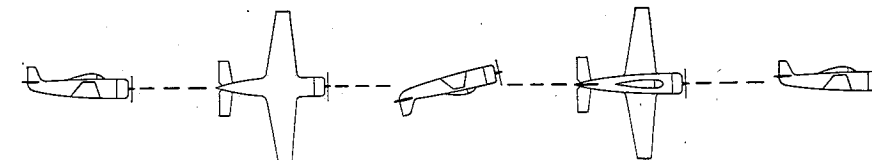

Slow roll.

slipper tank. An auxiliary fuel tank form-fitted up against an aircraft.

slipstream, noun. 1. The stream of air driven backward by a rotating propeller. 2. a. The stream of air driven downward by a powered rotor. *Rare.* See DOWNWASH. b. Loosely, the airstream past an aircraft, a rocket, etc. *Rare.*

slip tank. On an airship, a secondary fuel tank which may be "slipped" through the bottom of the ship when necessary to lighten the load.

slot, noun. A long and narrow opening, as between a wing and a deflected Fowler flap; specif., a long and narrow spanwise passage in a wing, usually near the leading edge, for improv-

ing flow conditions at high angles of attack. See AUTOMATIC SLOT, FIXED SLOT, SUCTION SLOT.

slot-lip aileron. A type of aileron consisting of a hinged flap-type spoiler comprising the lip of a slot through a wing. The aileron lies partially over the slot along the upper surface of the wing and is deflected upward for control.

slotted aileron. An aileron having a specially contoured leading edge which, in conjunction with the wing, forms a slot for the smooth passage of air over the aileron upper surface when the aileron trailing edge is deflected downward.

slotted flap. A flap that exposes a slot between itself and the wing when deflected, or a flap consisting of a number of slim surfaces, or slats, fastened together with slots between them. See DOUBLE-SLOTTED FLAP, VENETIAN-BLIND FLAP.

slow roll. A roll (which see, sense 2) performed largely by movement of the ailerons, the rudder and elevators being used for trimming purposes, and the flight path remaining substantially straight throughout. Also called an "aileron roll."

slurry fuel. A fuel comprising a suspension of fine solid particles in a liquid.

small circle. A circle on the surface of a sphere, esp. the earth, whose plane does not pass through the center of the sphere.

smoke jumper. A forest-fire fighter who parachutes to the scene of a fire. See FIRE JUMP.

snaking, noun. A weaving of an aircraft, missile, etc. from side to side; technically, a persistent directional oscillation of constant amplitude.

snap roll. A roll (which see, sense 2), in which the airplane is first brought sharply nose-up, then rolled by a quick application of the rudder in the desired direction of roll. This roll is essen-

tially a spin executed in horizontal flight.

snap-roll, *verb tr.* To cause (an airplane) to make a snap roll.—*intr.* To make a snap roll, as, the plane (or the pilot) *snap-rolled*.

sniffler valve. Also *sniff valve*. A valve in a pressurized system, such as a pressurized cooling system, that allows air to enter the system when the pressure in the system drops below the ambient pressure.

soar, *verb intr.* To fly along without engine power, esp. in a sailplane, maintaining or gaining altitude from ascending air currents.

—*soaring*, *noun*.

soaring glider. A *SAILPLANE*.

sock, *noun*. Same as *WIND SOCK*.

sock, *verb tr.* To be *socked in*. Of an

contain other components, as grids, liners, etc. See *ROCKET ENGINE* and *SOLID PROPELLANT*.

solo, *noun*. 1. Same as *SOLO FLIGHT*, as, he was ready for *solo*. 2. An act or instance of soloing.

solo, *verb*. 1. *intr.* To make a solo flight. 2. *tr.* To pilot (an aircraft) in solo flight, as, to *solo* a helicopter. *Rare*.

solo, *adj.* Performed by oneself and alone, as in *solo attempt*, *solo ocean crossing*.

solo, *adv.* Alone, as, to fly the ocean *solo*, or, to fly an airplane *solo*.

solo flight. A flight in which the pilot is alone in the aircraft.

sonic, *adj.* 1. *Aerodynamics*. Of or pertaining to the speed of sound (see *SPEED OF SOUND*); that moves at the speed of sound, as in *sonic flow*; de-

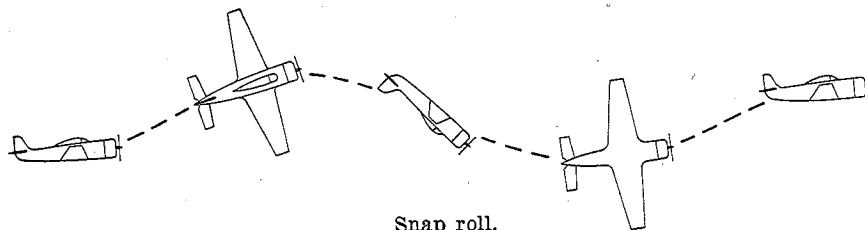

Snap roll.

airport, an airfield, etc.: To be closed to flying operations for a lack of visibility. *Popular*.

solidity, *noun*. Short for *SOLIDITY RATIO*.

solidity ratio. 1. Of a propeller or rotor, the ratio of the total projected area of the blades to the disk area. 2. Of a turbine or axial-flow compressor, the ratio of blade chord to blade pitch.

solid propellant. *Specif.*, a rocket propellant in solid form, usually such a propellant containing both fuel and oxidizer combined or mixed in a monolithic (not powdered or granulated) form. See *ROCKET PROPELLANT* and *GRAIN*.

Many different solid propellants exist, such as ammonium perchlorate plus polyurethane rubber with various additives; and various compounds containing chiefly nitroglycerine and nitrocellulose.

solid-propellant rocket engine or motor. A rocket engine or motor using a solid propellant. Such motors consist essentially of a combustion chamber containing the propellant, and a nozzle for the exhaust jet, although they often

signed to operate or perform at the speed of sound, as in *sonic leading edge*. 2. Of or pertaining to sound, as in *sonic amplifier*.

sonic altimeter. An experimental form of altimeter that measures absolute altitude by means of the elapsed time interval between the transmission of a distinctive sound from an aircraft and the return of its echo from the surface.

sonic barrier. A popular term for the large increase in drag that acts upon an aircraft approaching the speed of sound. Also called the "sound barrier."

sonic boom. A noise caused by a shock wave that emanates from an aircraft or other object traveling at or above the speed of sound. A shock wave is a pressure disturbance, and is received by the ear as a noise or clap.

sonic speed. The speed of sound.

Sound travels at different speeds through different mediums and at different speeds through any given medium under different conditions of temperature, etc. In the standard atmosphere at sea level, *sonic speed* is approximately 1100 fps, or 760 mph.

sound barrier. Same as *SONIC BARRIER*. *Popular*.

sounding, *noun*. *Specif.*, same as *AIR SOUNDING*.

sounding balloon. A small free balloon that carries aloft air-sounding equipment, esp. self-registering or telemetering equipment. See *AIR SOUNDING*.

sounding rocket. A rocket that carries aloft air-sounding equipment. See *AIR SOUNDING* and cf. *PROBE*, sense 3.

source, *noun*. In the mathematical representation of fluid flow, a hypothetical point or place from which fluid emanates.

span, *noun*. 1. a. The dimension of an airfoil from end to end, from tip to tip, or from root to tip; the measure of this dimension. b. The dimension of an airplane, measured between lateral extremities. 2. a. More particularly, the dimension of an airfoil from tip to tip, measured in a straight line. Where ailerons or elevators extend beyond the tips of the airfoil proper, their extension is included in the span. Sweeping an airfoil or giving it dihedral decreases the span. b. *Specif.*, *WING SPAN*.

"Span" is not normally applied to vertical airfoils; see *HEIGHT*, senses 2 and 3. Cf. *CHORD* and *LENGTH*. See *EFFECTIVE SPAN*.

span axis. An axis directed along the span of an airfoil. See *AXIS*, sense 1.

span load distribution. The disposition of the load or loads on an airfoil measured along the span, i. e., the load per unit length measured in the spanwise direction.

span loading. The ratio of the weight of an airplane to its span or to the span of its equivalent monoplane wing.

spanwise, *adj.* Moving, located, or directed along the span, as in *spanwise flow*.

spanwise, *adv.* Along the span, or in the direction of the span, as, to aim (a camera) *spanwise*.

spar, *noun*. *Specif.*, a principal spanwise beamlike member in the structure of a wing or other airfoil. See *AUXILIARY SPAR*, *FALSE SPAR*; cf. *LONGERON*.

spar cap. A flange of a spar; an upper or lower strip running the length of a spar.

spark-ignition engine. An internal-combustion reciprocating engine in which the fuel-air mixture is ignited on

each power stroke by an electric spark. Cf. *COMPRESSION-IGNITION ENGINE*.

spat, *noun*. A teardrop-shaped fairing around the wheel of a fixed landing gear on certain airplanes. *Usually in plural*, "spats." Also called "pants." **specific fuel consumption**. The amount of fuel, measured in pounds per hour, consumed or required by an engine for each horsepower or pound of thrust developed.

Brake specific fuel consumption is the amount of fuel per hour used for each brake horsepower; *indicated specific fuel consumption* is the amount of fuel per hour used for each indicated horsepower; *thrust-horsepower specific fuel consumption* is the amount of fuel per hour used per thrust horsepower; and *thrust specific fuel consumption* is the amount of fuel per hour used per pound of thrust.

specific impulse. The thrust produced by a jet-reaction engine per unit weight of propellant burned per unit time, or per mass of working fluid passing through the engine in unit time, usually expressed as pounds per pounds per second which is commonly called "seconds." See *IMPULSE*.

specific propellant consumption. The ratio of the amount of propellant consumed per unit time to the thrust of a rocket engine.

specific thrust. 1. The thrust in pounds produced by a jet engine or by a propeller per pound of airflow per second. 2. *Rocketry*. Equivalent to *SPECIFIC IMPULSE*.

speed, *noun*. Rate of motion relative to a frame of reference; *specif.*, *AIR SPEED*. See *GROUND SPEED*, *RPM*, *VELOCITY*, sense 1 and note.

speed brake. An air brake in the form of a flap or plate. Also called a "drag brake." See *AIR BRAKE*, sense 1.

speed-density control. A type of control that meters fuel to an engine in response to variations in rpm, air density, intake manifold pressure and temperature, and exhaust back pressure.

speed line. A line of position as plotted on a chart, perpendicular, or almost so, to the course of an aircraft, and showing the distance along the course the aircraft has flown.

speed of sound. The speed at which sound travels in a given medium under given conditions. See *SONIC SPEED*.

Speedpak, *noun*. [A trade name.] A kind of carrier that fits externally to the bottom of a fuselage for carrying extra cargo, mail, or luggage.

spin, noun. A maneuver or performance of an airplane, controlled or uncontrolled, in which the airplane descends in a helical path while flying at an angle of attack greater than the angle of maximum lift. The nose of an airplane in a spin is usually, though not necessarily, pointed sharply downward.

See **FLAT SPIN, INVERTED SPIN, NORMAL SPIN, PRECISION SPIN.**

spin, verb. 1. *intr.* Of an airplane: To perform a spin. 2. *tr.* To make (an airplane) perform a spin.

spinner, noun. Something that spins, such as a radar antenna, etc.; specif., a conical or parabolic fairing affixed coaxially with a propeller and which revolves with the propeller.

spinproof, adj. Of an airplane: Highly resistant to spinning, or incapable of spinning.

spin-stabilized, adj. Of a projectile: Stabilized in flight by a rotating motion about its longitudinal axis, as in *spin-stabilized* rocket. Cf. **FIN-STABILIZED.**

spin tunnel. A type of tunnel in which unmounted model airplanes are made to spin in a vertical air blast.

The air speed in the spin tunnel may be kept equal to the rate of descent of a tested model, causing the model, while spinning, to remain at a given height relative to the observer.

spiral, noun. A maneuver or performance, esp. of an airplane, in which the craft ascends or descends in a helical (corkscrew) path, disting. from a spin in that the angle of attack is within the normal range of flight angles; the flight path of an aircraft so ascending or descending.

spiral, verb intr. To fly in a spiral path.

spiral dive. A dive in which the airplane spirals.

spiral glide. A glide in which the airplane spirals.

spiral instability. A form of instability of an airplane which causes it, when the airplane is in a banked turn, to assume too great a bank and to sideslip, the bank continuing to increase and the radius of turn to decrease.

spiral stability. The property of an airplane to recover of itself from a steeply banked downward spiral, or the property of an airplane not to enter a

spiral from a banked turn. See **SPIRAL INSTABILITY.**

split flap. 1. A plate or surface hinged to the bottom of a wing, usually near the trailing edge, deflected downward for increased lift and drag. 2. An **UPPER-SURFACE AILERON.** *Rare.*

split-S, noun. An airplane performance or maneuver consisting of a half snap roll or half slow roll followed by an inverted half-loop (usually an inverted inside half-loop), resulting in a reversal of the direction of flight of the airplane. See **HALF-ROLL.**

spoiler, noun. A plate, series of plates, comb, tube, bar, or other device that projects into the airstream about a body to break up or spoil the smoothness of the flow, esp. such a device that projects from the upper surface of an airfoil, giving an increased drag and a decreased lift. Cf. **DEFLECTOR**, sense a.

Spoilers are normally movable, and consist of two basic types: the flap-type spoiler, which is hinged along one edge and lies flush with the airfoil or body when not in use, and the retractable spoiler, which retracts edgewise into the body.

spoiler aileron. A movable or retractable spoiler intended for the lateral control of an airplane.

spoileron, noun. [*Spoiler* + *aileron*.] Same as **SPOILER AILERON.**

spoiler-slot aileron. A combination lateral-control device consisting of a slot and spoiler combination, the slot being closed or covered by the spoiler when the spoiler is in the retracted or undeflected position.

sponson, noun. 1. In general, a conspicuous projection, esp. a structural projection, from the side of an aircraft's hull or ship's hull or from the side of an airplane's fuselage, such as a broad lateral strut helping to support the fixed landing gear on a certain type of aircraft. 2. *Specif.:* a. A structural protuberance or enclosure appearing as a kind of ridge running along the side at the bottom of a flying-boat hull, providing additional planing surface and increasing lateral stability. b. A **SEA WING.**

spontaneous-ignition temperature. In testing, the lowest temperature of a plate or other solid surface adequate to cause ignition in air of a fuel upon the surface.

spool, noun. 1. An assembly of an axial-flow compressor rotor and a turbine

wheel on a common shaft. 2. In some contexts, an axial-flow compressor rotor by itself.

spot landing. An airplane landing in which the pilot attempts to make initial contact with the ground during a landing at a pre-selected spot. Same as **ACCURACY LANDING.**

The spot landing is usually a training exercise, intended to aid the student in evaluating wind, in coordinating his actions, etc.

spray strip. A strip affixed to a seaplane hull to deflect the spray.

spreader bar. A bar or brace that maintains a given space between two things; esp., a horizontal member between the two wheels, floats, etc. of a landing gear.

spring tab. A tab (which see) attached to a control surface and actuated through a control linkage spring-loaded in such a manner that the tab supplies a certain amount of the force necessary to move its control surface. Its action and use are similar to those of the servo tab, but the springs incorporated in the control system work so as to make the tab supply only a part, rather than all, of the force required to move its surface.

springy tab. A tab (which see) that has a constant torque applied about its hinge axis by a spring, its degree of deflection being determined by the dynamic pressures acting upon the tab. The tab is intended to cancel out variation of the control-surface hinge moment with changes in air speed.

squadron, noun. 1. A military, naval, or semimilitary aviation organization, variously defined. In the AF, the squadron is immediately superior to the flight and immediately inferior to the group. 2. A formation of aircraft, usually six or more. 3. A fleet of rockets or missiles.

squat, noun. A downward displacement of a seaplane while running on the water.

squeeze, verb tr. To squeeze the courses. To bring adjacent courses in a four-course radio range closer together while maintaining a straight-line relationship with reciprocal courses, the effect being similar to the partial closing of a pair of scissors. Cf. **BEND**, sense 1.

squib, noun. Any of various small explosive devices; a small pyrotechnic device; an electrical device, either used as a rocket or jet-engine igniter or as a primer for a pyrotechnic igniter. See **IGNITER.**

squidding, noun. The action of a deployed parachute in assuming an elongated, squidlike shape.

stabilator, noun. [*Stabilizer* + *levator*.] A horizontal all-movable tail. See **ALL-MOVABLE TAIL.**

stability, noun. *Specif.:* 1. The property of a body, as an aircraft or rocket, to maintain its attitude or to resist displacement, and, if displaced, to develop forces and moments tending to restore the original condition. See note. 2. *Meteorol.* The condition that exists in a body of air when there is resistance to the vertical displacement of air within it. 3. Of a fuel, the capability of a fuel to retain its characteristics in an adverse environment, e. g. extreme temperature.

In sense 1, see **AERODYNAMIC STABILITY, AUTOMATIC STABILITY, DIRECTIONAL STABILITY, DYNAMIC STABILITY, INHERENT STABILITY, LATERAL STABILITY, LONGITUDINAL STABILITY, NEUTRAL STABILITY, SPIRAL STABILITY, STATIC STABILITY.**

stability axis. Any one of a system of mutually perpendicular reference axes used for mathematical convenience in treating of the stability of an aircraft or similar body. See **AXIS**, sense 2 and note.

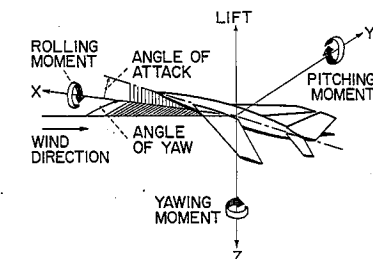

Stability axes, X, Y, Z. Arrows indicate positive direction of angles, forces, and moments.

stability derivative. A partial derivative of a function showing the relation between a force or moment acting on an aircraft in steady flight and the motion or variable causing the force or moment.

Stability derivatives are known as lateral stability derivatives, rotational stability derivatives, etc., depending on the motion involved.

stabilizer, noun. A fixed or adjustable airfoil or vane that provides stability for an aircraft, i. e., a fin (which see, sense 1); specif., the horizontal stabilizer on an airplane.

The plural form of the word, "stabilizers," is sometimes used in reference to an airplane's horizontal stabilizer distinctly separated into two parts by the fuselage. See ADJUSTABLE STABILIZER, FIXED STABILIZER, HORIZONTAL STABILIZER, VERTICAL STABILIZER.

The word "stabilizer" is not applied to the fin of a rocket or bomb.

stabilizer bar. In certain rotor systems, a weighted, rotating bar that tends to maintain its plane of rotation in tilting motions of the drive shaft, linked to the pitch-changing mechanism so as to cause the rotor blades to rotate in a plane parallel to its own.

stabilizing float. A small float used to stabilize a seaplane in the water, usually one of a pair attached to the wings on either side of a flying boat or single-float seaplane.

See INBOARD STABILIZING FLOAT, OUTBOARD STABILIZING FLOAT.

stable oscillation. Oscillation whose amplitude decreases with time.

stack, noun. 1. A group or number of orbiting aircraft at different altitudes above an airdrome awaiting turns to land. 2. An EXHAUST STACK.

stage, noun. 1. A step or process through which a fluid passes, esp. in compression or expansion. 2. A set of stator blades and a set of rotor blades in an axial-flow compressor or in a turbine; an impeller wheel in a radial-flow compressor. See MULTISTAGE COMPRESSOR, SINGLE-STAGE COMPRESSOR, SINGLE-STAGE TURBINE. 3. The propulsion unit of a rocket, esp. one of the propulsion units of a multistage rocket including its own fuel and tanks. See MULTISTAGE ROCKET.

stagger, noun. With two or more superposed objects or objects fixed in a row, the advance, or the amount of advance, of one object ahead of another, as of one wing of a biplane ahead of the other, of a compressor stator blade ahead of another, or of one rotor of a tandem-rotor helicopter ahead of the other.

A customary method for measuring the stagger at any section of the wings of a biplane or multiplane is by the acute angle between a line joining the axes of the upper and lower wings and a line perpendicular to the upper wing chord, both lines lying in

a plane parallel to the plane of symmetry. The stagger is positive when the upper wing is ahead of the lower.

stagger wire. On a biplane, a diagonal wire, usually one of a pair forming an X, running fore and aft between the two wings and helping to maintain a constant stagger.

stagnation point. A point in a field of flow about a body where the fluid particles have zero velocity with respect to the body.

stagnation pressure. The pressure at a stagnation point. It is the sum of impact and static pressure. See PITOT PRESSURE, TOTAL PRESSURE.

stall, noun. 1. a. A condition in which a wing or other dynamically lifting body flies at an angle of attack greater than the angle of maximum lift, resulting in a loss of lift and an increase of drag. See ANGLE OF MAXIMUM LIFT, BUBBLE; see also TIP STALL. b. A loss of lift and an increase of drag brought on by a shock wave, i. e., a shock-stall (which see). c. A condition of the flow about the blade or blades of a compressor, analogous to the stall described in sense 1a, above. See BLADE STALL, COMPRESSOR STALL, ROTATING STALL. 2. The flight condition or behavior of an aircraft flying at an angle greater than the angle of maximum lift; any of various airplane performances involving a stall. See ACCELERATED STALL, HAMMERHEAD STALL, WHIP STALL.

stall, verb. 1. *intr.* Of an aircraft or persons within: To go into a stall. 2. *intr.* Of an airfoil or blade: To undergo or enter a condition of flow such that a stall results—also said of a compressor or turbine. 3. *tr.* To put (an aircraft) into a stall.

stall fence. A FENCE.

stall flutter. Flutter involving periodic stalling and unstalling of the airfoil.

stalling angle, or, less often, stalling angle of attack. 1. The minimum angle of attack of an airfoil or airfoil section or other dynamically lifting body at which a stall occurs, i. e., a CRITICAL ANGLE OF ATTACK. 2. The ANGLE OF MAXIMUM LIFT.

stalling speed. The air speed at which, under a given set of conditions, an aircraft will stall.

standard atmosphere. A fictitious atmosphere of assumed composition and

characteristics, used as a standard for comparing the performance of aircraft, for calibrating altimeters and similar instruments, etc. A standard atmosphere represents the average conditions found in the actual atmosphere in a particular geographical region.

Several different standard atmospheres are in use. The National Advisory Committee for Aeronautics adopted the ICAO (International Civil Aviation Organization) Standard Atmosphere, which represents the average conditions prevailing at about 40° latitude in North America. This atmosphere is assumed dry, and to have a pressure of 760 mm. (about 29.92 in.) of mercury at 15° C. (59° F.) at mean sea level. This atmosphere is completely defined up to 65,000 feet altitude in NACA Report No. 1235. Values for altitudes above 65,000 feet are given in "The ARDC Model Atmosphere" USAF Surveys in Geophysics, No. 86, 1956. NACA Report No. 538 describes an altimeter-calibration standard atmosphere, based on slightly different averages, for altitudes up to 80,000 feet.

standard datum plane. A datum plane at sea level of a standard atmosphere, used in atmospheric pressure measurements or in the calibration of pressure-activated instruments. See SEA LEVEL.

standard rate turn. A turn in an aircraft in which the heading changes at the rate of 3 degrees per second.

starboard, noun. 1. The right side of an aircraft or vessel, as, a strut interchangeable from port to starboard. 2. The area or direction to ones right, as, a turn to starboard.

See RIGHT, *noun and adj.*

starboard, adj. Situated on or at the right, as in starboard engine; coming from the right, as in starboard cross wind. See RIGHT, *adj.*

starting vortex. In the theory of circulation, a spanwise vortex that is shed at the trailing edge of an airfoil at the beginning of the motion of the airfoil and left behind as the airfoil proceeds.

The starting vortex is considered to join the free vortices at the open end of a horseshoe vortex, thus satisfying the condition that a vortex cannot end within a fluid.

static balanced surface. A control surface designed or weighted so that it is in balance about its hinge axis. See MASS BALANCE.

static ceiling. The altitude in a standard atmosphere at which an airship or balloon, with its envelope or cells completely occupied by the aerostatic gas, neither rises nor lowers after the discharge of all ballast.

static discharger. A specially treated fibrous wick attached to the trailing edge of a wing or other surface to discharge static electricity in flight.

static lift. AEROSTATIC LIFT.

static line. 1. A line, as of wire or webbing, secured at one end to the rip cord or parachute pack and at the other end to the aircraft, the line serving to open the pack or withdraw the parachute as it falls with its burden. See ATTACHED-TYPE PARACHUTE. 2. A line of tubing that transmits static pressure, as in a pitot-static system.

static load. A load imposed under static conditions, such as the load imposed upon the wings of an aircraft in unaccelerated flight by the weight of the aircraft.

static margin. The distance between the actual center of gravity and the neutral point of an aircraft, usually expressed as a percentage of the mean aerodynamic chord.

static pressure. The unit force that a fluid exerts, excluding that due to (relative) motion of the fluid.

static stability. The property of a body (such as an aircraft) in a state of steady flight, to develop restoring forces or moments when disturbed. Cf. DYNAMIC STABILITY.

static thrust. Thrust without translational motion; the thrust produced under the given conditions by a jet engine at rest (static jet thrust) or by a propeller at rest with respect to the surrounding air except for the air motion owing to the propeller rotation (static propeller thrust).

static trim. Specif., the trim of an airship when not subjected to any dynamic forces.

static tube. A tube or tube arrangement used in measuring the static pressure of a moving fluid, the tube being provided with one or more openings that are presented to the fluid so that the stream flows across them. A static tube is combined with a pitot tube in the pitot-static tube for the measurement of airspeed; the static pressure provided by the tube may in addition be used in the operation of certain other instruments. See PITOT-STATIC TUBE and note.

station, noun. 1. An airship station or air station. 2. A location on an aircraft; distance from a reference point, e. g., the nose.

station pressure. Specif., the actual existing atmospheric pressure at an air-drome weather station, not corrected to the elevation of the runway.

stator, noun. In machinery, a part or assembly that remains stationary with respect to a rotating or moving part or assembly, such as the field frame of an electric motor or generator, or the stationary casing and blades surrounding an axial-flow compressor rotor or turbine wheel; a **STATOR BLADE**.

stator blade. A blade or vane that remains stationary with respect to a rotating blade and that serves to guide or direct a flow, as in an axial-flow compressor or in a turbine.

statoscope, noun. A highly sensitive barometer or altimeter for measuring slight variations in pressure or altitude.

steady flight. Nonaccelerated, nonoscillating flight.

steady flow. A flow whose velocity components at any point in the fluid do not vary with time. See **STREAMLINE FLOW**.

steady state. The condition of a substance or system whose local physical and chemical properties do not vary with time.

steep, adj. Making a large angle with the horizontal, as in *steep* dive, *steep* turn (a turn with the wings sharply banked).

stellar guidance. Same as **CELESTIAL GUIDANCE**.

stem, noun. The foremost part of a boat, seaplane hull, or float; the prow.

step, noun. Specif., an abrupt break or jog in the bottom of a seaplane float or hull, changing the transverse section and placing the bottom of that part of the body aft of the step at a higher level than the bottom of that part forward of the step. The purpose of the step is to diminish resistance, to lessen suction effects, and to improve control over the longitudinal attitude.

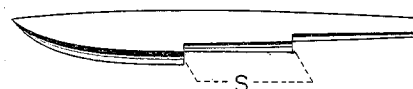

Steps in a two-step float.

step rocket. Same as **MULTISTAGE ROCKET**.

stern, noun. The aft part of something. Applied in aeronautics to the aft part of an aircraft, esp. of an airship or flying boat, or to the aft part of a float. Cf. **TAIL**.

sternheavy, adj. Having a tendency to sink at the stern. Applied esp. to airships. Cf. **BOWHEAVY**, **TAILHEAVY**.

sternpost, noun. 1. The vertical edge at the rear of a tapered planing surface. 2. A **TAIL POST**. 3. On certain airships, a post at the rear of a fin. See **RUDDER-POST**, sense 3.

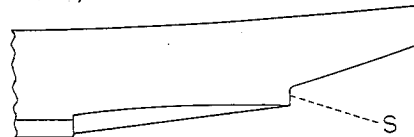

Sternpost, sense 1.

steward, noun. Specif., a crew member aboard a passenger-carrying aircraft who supervises the passengers and attends their needs.

—**stewardess, noun.**
stick, noun. A **CONTROL STICK**.

stick force. Specif., the force required for a pilot to move the control stick or control column.

sticking, noun. The action of a seaplane or flying boat "adhering" to the water at high speed during the take-off run, owing to the increased water resistance.

stiffener, noun. A stringer, batten, or the like used to stiffen, or give shape and rigidity to something. See **BATTEN**, sense 2, **STRINGER**.

sting, noun. A long, slender, tapered mount, suggestive of the sting of an insect, for a model or test object in a wind tunnel.

In some cases, stings are adjustable and contain pressure tubes, etc. The test object is mounted at the sting's tip, the sting being aligned with the airstream.

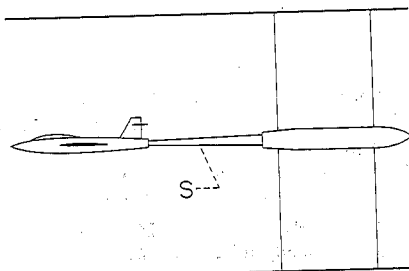

Sting.

stoichiometric, adj. Of a combustible mixture: Having the exact proportions required for complete combustion.

STOL, or, rarely, S. T. O. L.—Abbreviation for *short take-off and landing*—pronounced by letter or, sometimes, as a word ("stole"), used: (1) as an attributive adjective designating heavier-than-air aircraft capable of taking off and landing within a relatively short horizontal distance (sometimes specifically defined in particular context), as in *STOL* airplane, and (2) as a noun meaning an aircraft that can take off, and land, within a relatively short distance.

stop, noun. A **LIMIT STOP**.

straight-flow combustion chamber. A type of combustion chamber in which fuel and air are introduced at the front end, the gases resulting from burning being passed through the chamber to the exhaust end without reversal. This is the commonest type of combustion chamber. Also called a "through-flow combustion chamber." Cf. **REVERSE-FLOW COMBUSTION CHAMBER**.

straight wing. An unswept wing.

strain gage. An instrument used to measure the strain or distortion in a member or test specimen (such as an aircraft structural part) subjected to a force.

stratopause, noun. The upper boundary of the stratosphere.

stratosphere, noun. A layer or region of the earth's atmosphere lying immediately above the troposphere and characterized by approximately uniform temperature and an absence of storms or turbulence.

The lower limit of the stratosphere varies with conditions and with latitude, but it is considered to be at a height of about 6 or 7 miles. Different authorities consider the upper limit to be either at about 20 miles or at about 50 miles. In the former case its top boundary would meet the chemosphere; in the latter case it would meet the ionosphere. See **ISOTHERMAL LAYER**.

streamline, noun. The path of a particle or small portion of a fluid, usually a noneddying fluid, commonly taken with respect to a body in it; more technically, such a path whose tangent at any point is in the direction of the velocity vector at that point.

streamline, verb. 1. *tr.* To shape (something) so that it creates as nearly as possible a streamline flow (i. e., a non-

eddying flow) about it. 2. *tr.* To bring (a control surface or the like) into alignment with the streamlines past it. 3. *intr.* To align with streamlines, as, the rudder *streamlined*; to follow streamlines, as, the surfaces *streamline* into each other.

streamline flow. A smooth, nonturbulent flow, essentially fixed in pattern; **STEADY FLOW**.

streamlining, noun. 1. The action of the verb *streamline*. 2. A feature of a body or surface that has been streamlined, as, an airplane with proper *streamlining*. 3. A piece or structure that serves to streamline, such as a fairing.

stream tube. In aerodynamic theory, a tube of fluid whose surface is formed by a group of streamlines.

Since no flow can cross a streamline, the same amount of fluid per unit time will pass each section of the stream tube, even though the tube is of varying section. The concept is useful in developing equations expressing continuity of flow.

stress cycle. A variation of stress with time, repeated periodically and identically.

stressed-skin construction. A type of construction, as of an airplane fuselage or wing, in which the skin bears all or part of the structural load the structure must withstand.

Monocoque and semimonocoque structures are of stressed-skin construction.

stress raiser. A scratch, groove, rivet hole, forging defect, or structural discontinuity giving rise to a local concentration of stress.

stress ratio. The ratio of the minimum stress to the maximum stress occurring in one stress cycle.

stringer, noun. A slender, lightweight, lengthwise fill-in structural member in a fuselage, wing, nacelle, etc., serving to reinforce and give shape to the skin.

strip, noun. A long, narrow, cleared strip of land, usually hard-surfaced, for the take-off and landing of airplanes.

See **AIRSTRIPE**, **FLIGHT STRIP**, sense 1, **LANDING STRIP**.

stroke, noun. In a reciprocating engine, the movement of a piston between dead-center positions; the distance of this movement.

In a four-stroke-cycle engine, the strokes necessary to complete a cycle are the *intake*

stroke, compression stroke, power stroke, and exhaust stroke. (See individual entries.)

structural weight. 1. The weight of the airframe of an aircraft. 2. Of a rocket: Same as CONSTRUCTION WEIGHT.

strut, noun. A type of supporting brace, i. e., a rigid member or assembly that bears compression loads, tension loads, or both, as in a fuselage between the longerons, in a landing gear to transmit the airplane loads, etc.

See CABANE STRUT, DRAG STRUT, FUSELAGE STRUT, INTERPLANE STRUT, JURY STRUT, LIFT STRUT, SBOCK STRUT.

stub wing. Also, less often, stubwing, *noun.* 1. A wing of short span low aspect ratio, as on the earlier autogiro. 2. That part of an airplane's wing near the fuselage or hull to which the rest of the wing, separately constructed, is attached. The stub wing may contain a jet engine or a jet-engine inlet duct. Also called a "wing-stub." 3. Also stub-wing stabilizer. A SEA WING.

stunt, verb. 1. *tr.* To make (an aircraft) perform an aerobatic feat or series of feats, as, to *stunt* a glider. 2. *intr.* To perform an aerobatic feat or feats.

stunt flier. A pilot who performs stunts in an aircraft, esp. an airplane or glider, such as dives, loops, spins, etc. Cf. AERIAL ACROBAT.

subcloud car. A car or nacelle, formerly used on airships, which was lowered beneath the clouds to make observations, as in bombing.

subsonic, adj. Aerodynamics. Of or pertaining to, or dealing with, speeds less than the speed of sound (see SONIC SPEED), as in *subsonic* aerodynamics; less than the speed of sound, as in *subsonic* speed; that moves slower than the speed of sound, as in *subsonic* aircraft, *subsonic* airstream; designed to operate or perform at speeds below the speed of sound, as in *subsonic* airfoil, *subsonic* ramjet.

subsonic diffuser. A diffuser designed to reduce the velocity and increase the pressure of fluid moving at subsonic velocities.

subsonic flow. Flow at a velocity less than the speed of sound in the medium under the prevailing conditions.

stratosphere, noun. A region of indefinite lower limit just below the stratosphere.

The stratosphere is not a recognized region of the atmosphere in scientific contexts. The term is used only informally, as in "The airliners cruise through the *stratosphere* at 300 miles an hour."

suction slot. A slot in a surface, such as a wing's surface, through which boundary-layer air is removed by suction.

suction stroke. Same as INTAKE STROKE.

sun compass, noun. A type of astrocompass (which see) with which direction is determined by reference to the sun.

sunline, noun. A line of position derived from a sextant observation of the sun.

superaerodynamic, adj. Of or pertaining to superaerodynamics.

superaerodynamics, noun. A specialized branch of aerodynamics dealing with gases at very low densities.

In this field, gas (e. g., air at very high altitudes) does not behave like a continuum; kinetic theory must be employed for analysis.

supercharge, verb tr. 1. To force more air or fuel-air mixture into (an internal combustion reciprocating engine) than the engine would induct under the prevailing atmospheric pressure. 2. To pressurize (in sense 1, which see).

—*supercharged, adj.* (in both senses), as in *supercharged* airplane (an airplane with a supercharged engine or with a pressurized cabin), *supercharged* cabin, etc.

supercharged engine. A reciprocating engine equipped with a supercharger, esp. an engine provided with a high degree of supercharging for operation esp. at relatively high altitudes. See ALTITUDE ENGINE.

supercharger, noun. A pump or compressor that supercharges, i. e., that increases the density of the air or fuel-air mixture supplied an internal-combustion reciprocating engine.

See AUXILIARY-STAGE SUPERCHARGER, CENTRIFUGAL SUPERCHARGER, EXTERNAL SUPERCHARGER, GEAR-DRIVEN SUPERCHARGER, INTERNAL SUPERCHARGER, MAIN-STAGE SUPERCHARGER, MULTISPEED SUPERCHARGER, MULTI-STAGE SUPERCHARGER, RECIPROCATING-TYPE SUPERCHARGER, ROOTS-TYPE SUPERCHARGER, TURBOSUPERCHARGER, VANE-TYPE SUPERCHARGER; see also BLOWER, sense 2 and note, COMPRESSOR and note.

supercirculation, noun. The provision of additional flow over an airfoil, as by air tapped from a compressor, so as to obtain more than the theoretical lift that would be obtained with potential flow.

superheat, noun. Specif., the difference between the temperature of the gas in a balloon or airship and the temperature of the surrounding air. If the aerostatic gas has a higher temperature than the air, the superheat is said to be positive.

superpressure, noun. The excess of pressure of the aerostatic gas in an envelope, taken at the bottom, over the atmospheric pressure.

supersonic, adj. Aerodynamics. Of or pertaining to, or dealing with, speeds greater than the speed of sound (see SONIC SPEED), as in *supersonic* aerodynamics; greater than the speed of sound, as in *supersonic* velocity; that moves faster than the speed of sound, as in *supersonic* flow; designed to operate or perform at speeds above the speed of sound, as in *supersonic* airfoil, *supersonic* wind tunnel; that occurs at speeds greater than the speed of sound, as in *supersonic* shock-wave reflection.

supersonic compressor. A compressor in which a supersonic velocity is imparted to the fluid relative to the rotor blades, the stator blades, or to both the rotor and stator blades, producing oblique shock waves over the blades to obtain a high pressure rise.

supersonic diffuser. A diffuser designed to reduce the velocity and increase the pressure of fluid moving at supersonic velocities.

supersonic flow. Flow at a speed greater than the speed of sound in the medium under the prevailing conditions.

supersonic leading edge. A surface leading edge having a sweep less than the sweep of the Mach line at the particular supersonic Mach number considered. For such sweep, the component of the stream velocity normal to the leading edge is supersonic.

supersonic nozzle. A converging-diverging nozzle designed to accelerate a fluid to supersonic speed.

supersonics, noun. Specif., supersonic aerodynamics. See SUPERSONIC; also cf. HYPERSONICS.

surface, noun. 1. A two-dimensional extent; the outside or superficies of any body; esp., in aeronautical contexts, the surface of the earth, either land or water. 2. A wing, rudder, propeller blade, vane, hydrofoil, or the like—ap-

plied in this sense to the entire structure or body.

surface ignition. The ignition of the combustible mixture in an engine cylinder by a hot surface.

surface-to-air, adj. From the earth's surface to the air; designed to be sent from the earth's surface to the air, as in *surface-to-air* missile.

surge, noun. A transient rise in power, pressure, etc., such as a brief rise in the discharge pressure of a rotary compressor.

suspension line. A line that suspends, or helps to suspend, something; specif., a SHEROUD LINE.

suspension patch. A patch attached to the bag or envelope of a balloon or airship, attaching a line suspending a car or nacelle.

swash plate, or swashplate, noun. On certain rotary-wing aircraft, an assembly, part of which rotates with, and is linked to, the blades, used to control the pitch of the blades. Also called a "wobble plate." See CYCLIC PITCH CONTROL.

sweep, noun. The slant of a wing or other airfoil, or of a reference line in an airfoil, with respect to a plane perpendicular to the longitudinal axis of the aircraft, i. e., SWEEPBACK or SWEEPFORWARD; the ANGLE OF SWEEP.

sweep, verb tr. Usually in the phrases, to *sweep* (an airfoil, etc.) *back* or *forward*. To slant (an airfoil, or, sometimes, the leading or trailing edge or other reference line of an airfoil) either backward, such that the outboard portion is aft of the inboard portion, or forward, such that the outboard portion is forward of the inboard portion.

sweep angle. Same as ANGLE OF SWEEP.

sweepback, noun. 1. The backward slant from root to tip (or inboard end to outboard end), of an airfoil, or of the leading edge or other reference line of an airfoil. "Sweepback" usually refers to a design in which both the leading and trailing edges of the airfoil have a backward slant. 2. The amount of this slant. See ANGLE OF SWEEP.

Sometimes called "backsweep."

sweepback angle. The angle of sweep of a sweptback airfoil. See ANGLE OF SWEEP.

sweepforward, noun. 1. The forward slant, from root to tip (or inboard end

to outboard end), of an airfoil, or of the trailing edge or other reference line of an airfoil. 2. The amount of this slant. See ANGLE OF SWEEP.

sweepforward angle. The angle of sweep of a sweptforward airfoil. See ANGLE OF SWEEP.

sweptback, adj. Having sweptback, as in *sweptback* empennage, *sweptback* leading edge, *sweptback* wing.

sweptforward, adj. Having sweepforward, as in *sweptforward* wing.

swept wing, or sweptwing, noun. A wing having sweep; esp., a wing having sweptback of both the leading and trailing edges.

Used attributively in compounds, such as *swept-wing* (less often, *sweptwing*) airplane, *swept-wing* platform, etc.

swing, verb tr. 1. To swing a propeller. To pull on a propeller so as to turn the engine over in starting. 2. To swing a

compass (or, sometimes, *to swing an aircraft*). See COMPASS SWINGING.

synchronizing gear. Specif., with an airplane's fixed machine guns firing through the propeller disk, a gear that synchronizes or interrupts the gunfire so that bullets will not strike the propeller blades. Also called an "interrupter gear."

synchronous motor. An electric motor that turns at the same speed as the alternator that supplies its current, used, e. g., in a magnetic tachometer. Also called a "self-synchronous motor."

synchropter, noun. [*Synchronized* or *synchronous* helicopter.] A helicopter with intermeshing rotors. See INTERMESH.

synchroscope, noun. Specif., an instrument of the voltmeter type that indicates a difference in the rotational speeds of an aircraft's engines.

T

tab, noun. A small auxiliary airfoil set into the trailing edge of an aircraft control surface (or sometimes set in, or attached to, another surface, such as a rotor blade) and used for trim or to move, or assist in moving, the larger surface.

Tabs are sometimes used on rotor blades for tracking the blades or for control purposes.

See BALANCING TAB, GEARED SPRING TAB, SERVO TAB, SPRING TAB, SPRINGY TAB, TRIM TAB.

tab angle. The angular displacement of a tab from its neutral position with respect to the control surface to which it is attached. For a horizontal tab, this angle is positive when the trailing edge is turned down from its neutral position; for a vertical tab, the angle is positive when the trailing edge is to port.

tacan, noun. [From "*tactical air navigation*"; sometimes capitalized.] An ultra-high-frequency electronic air-navigation system combining the functions of the omnidirectional radio range and of distance-measuring equipment to indicate the distance and bearing of an aircraft from a transmitting station.

tach, noun. [Pronounced "tack."] A clipped form of the word "tachometer." Popular.

tachometer, noun. An instrument that indicates, usually in revolutions per minute, the rotational speed of an engine, of a helicopter rotor, etc.

See CENTRIFUGAL TACHOMETER, CHRONOMETRIC TACHOMETER, ELECTRIC TACHOMETER, MAGNETIC TACHOMETER, MECHANICAL TACHOMETER, PERCENT-TYPE TACHOMETER.

tail, noun. 1. The rear part of a body, as of an aircraft, a rocket, a float, etc. Cf. STERN. 2. a. The tail surfaces of an aircraft; an EMPENNAGE; a TAIL ASSEMBLY. b. A HORIZONTAL TAIL OR VERTICAL TAIL.

tail assembly. The assembly of stabilizing surfaces or vanes and any control surfaces at the tail of an aircraft, missile, etc. On an aircraft, also called the "empennage."

tail boom. A slender outrigger structure attached to the wing or main body of an aircraft to support tail surfaces, a tail rotor, or some other tail component. See BOOM, sense a.

tailburner, noun. Same as AFTERBURNER. Rare.

tail cone. A segment or component having a cone or conelike shape at the rear end of something, such as the tapering rear part of an airplane fuselage; an EXHAUST CONE.

tail drive. A form of rocket propulsion (the usual form) in which the rocket exhaust issues from the tail.

tail fin. A fin (which see, sense 1) at the tail of a rocket or other body; a VERTICAL STABILIZER.

tail group. AN EMPENNAGE.

tailheavy, adj. Having a tendency to sink at the tail. Applied esp. to airplanes. Cf. NOSEHEAVY, STERNHEAVY.

tail hook. An arresting hook at the tail of an airplane. See ARRESTING GEAR.

tail length. The longitudinal distance between the center of gravity of an airplane and the aerodynamic center of the horizontal tail.

tailless airplane. 1. An airplane having only vertical surfaces at the tail. 2. A FLYING WING.

tailpipe, noun, or tail pipe. A pipe or duct on a jet engine that carries the exhaust gases rearward and discharges them through a nozzle; a rearwardly extending pipe that receives the exhaust gases from the manifold of a reciprocating engine and discharges them.

tailpipe burner. Same as AFTERBURNER.

tail plane, or tailplane, noun. 1. The horizontal stabilizer extending on both sides of an airplane, glider, or other heavier-than-air aircraft. See HORIZONTAL STABILIZER. 2. A HORIZONTAL TAIL.

tail post. The upright member at the extreme rear of certain fuselages. Also called a "sternpost" (which see).

tail rotor. On some rotary-wing aircraft, a rotor, usually an antitorque rotor, located at the tail. See ANTI-TORQUE ROTOR.

tail section. The rear section or portion of a fuselage, a hull, or other body, usually understood to include the tail assembly when present.

tail sitter. A type of VTOL aircraft designed to rest vertically upon its tail and to take off and land in the same position, using the same propulsion system, without conversion, for take off, landing, and horizontal flight. Chiefly popular.

This aircraft is commonly an airplane of more or less conventional design.

tail skid, or, infrequently, tailskid, noun. On certain airplanes, a skid attached to the rear part of the airplane on the underside and supporting the tail.

The tail skid also provides a braking action.

tail slide. A rearward motion of an airplane relative to the air, as occurs, e. g., in a whip stall.

tail spin, or tailspin, noun. A NORMAL SPIN (in sense 1).

tail surface. Either a stabilizing or a control surface at the tail of an aircraft.

tail wheel, or, infrequently, tailwheel, noun. On certain aircraft, a wheel at the tail used to support the tail section on the ground. A tail wheel may be retractable, steerable, fixed, castering, etc.

tail wind, or, infrequently, tailwind, noun. A wind blowing from directly behind, or blowing from such a direction that its principal effect is to increase ground speed.

take, verb intr. To take off. To leave the ground, water, or other surface (as a carrier deck) and begin flight—said of an airplane, an airship, a balloon, a helicopter, a rocket, etc. or of any persons within; to break contact with the surface (as a balloon or airship from its moorings) and begin flight or ascent; to perform a take-off.

take-off, or, infrequently, takeoff, noun.

1. An act or instance of taking off, as, an airship ready for *take-off*, or, an airplane that crashes at *take-off*; the operation of taking to the air, of leaving the ground, commencing, in the case of airplanes (and sometimes airships or other aircraft), with the beginning of the take-off run, with unmooring (balloons and airships), or with firing (rockets) and terminating at a time suggested by the context. The take-off may be considered to terminate when becoming airborne, when reaching a specified or understood height, etc. 2. A take-off run, as, the longer *take-offs* required for heavy airplanes. 3. *Restrictive.* An act or instance of becoming airborne, of breaking contact with the ground. 4. An act or instance of a number of aircraft taking off from the same place, simultaneously or in succession, as, the *take-off* of a squadron.

take-off distance. The distance required for the take-off run of an aircraft under the given conditions.

take-off horsepower. The maximum rated horsepower that an engine can

develop without damage to itself for a specified short period of time for take-off and initial climb.

take-off roll. The take-off run of a wheeled airplane. See TAKE-OFF RUN.

take-off run. The run, travel, or movement of an aircraft on the land, water, or other surface between the point of accelerating for the take-off and the point at which it becomes airborne.

take-off speed. 1. The speed, esp. the airspeed, at which an aircraft becomes airborne under the given conditions. 2. The rotational speed of an engine to be used for take-off conditions, as specified by the manufacturer.

take-off time. 1. The time for which a take-off is scheduled, or at which a take-off occurred. 2. The time elapsed during a take-off run; the time elapsed during the take-off of several aircraft.

take-off weight. The gross weight of an aircraft, rocket, etc., at take-off; the maximum gross weight with which an aircraft or other flying vehicle is designed or authorized to take off under the given conditions.

tandem airplane. 1. An airplane with two (usually) or more cockpits or seats one behind the other. 2. An airplane with two or more wings one behind another in approximately the same plane. See DOUBLE MONOPLANE.

tandem helicopter. Specif., a TANDEM-ROTOR HELICOPTER.

tandem landing gear. A main landing gear having two or more wheels or sets of wheels arranged one behind the other, usually a bicycle landing gear. See BICYCLE LANDING GEAR.

tandem propellers. A set or arrangement of propellers one behind the other, usually contrarotating propellers. See CONTRAROTATING PROPELLER, sense 2.

tandem-rotor helicopter. A helicopter with rotors one behind the other. Also called a "tandem helicopter."

tangent ogive. An ogive whose circular-arc contours have their centers on a line normal to the axis at the base of the ogive, the arcs thus being tangent to the surface of the cylindrical body behind the ogive. See OGIVE (illus.).

tanker, noun. An aircraft having a built-in tank or tanks for transporting liquid fuel or other liquid substance.

tanker aircraft. An aircraft designed or modified as a tanker (which see), esp.

for air refueling; also collective, as, ten tanker aircraft.

taper, noun. A gradual reduction in either the chord length or thickness of an airfoil, blade, or the like, esp. such a reduction from root to tip—the term usually refers to chord length unless otherwise indicated. See INVERSE TAPER.

taper ratio. Of an airfoil, the ratio of the tip chord length to the root chord length.

tare, noun. Specif., same as TARE DRAG.

tare drag. The drag of the supports of a test object in a wind tunnel.

taxi, verb. 1. *intr.* Of an aircraft or persons within: To move about on the ground, water, or other surface (as a carrier deck) under the craft's own power, except in take-off and landing runs, as, the pilot, or the aircraft, *tawied* to the take-off position. 2. *tr.* to move (an aircraft) about as indicated in sense 1, as, he will *taxi* the seaplane to the dock.

taxi channel. A water channel at a seaplane base reserved for taxiing.

taxiing, noun. The action of the verb *taxi*.

taxiway, noun. A prepared strip over which aircraft taxi to and from a runway, a hangar, etc.

taxying, noun. Same as TAXIING. *Obs.* and *rare*.

teetering rotor. Same as TILTING ROTOR.

telemeter, noun. An automatic radio transmitter used, e. g., in a sounding balloon or in a rocket, that sends out measurements of a quantity, such as speed, acceleration, temperature, etc.

telemeter, verb tr. and intr. To transmit by telemeter.

—telemetered, *adj.*, telemetering, *noun*.

temperature inversion. *Meteorol.* A condition in which the usual decrease of temperature with increasing altitude is inverted, i. e., in which the temperature increases with increasing altitude, rather than decreases.

terminal, noun. Specif., an AIR TERMINAL.

terminal ballistics. That branch of ballistics dealing with the motion and behavior of projectiles at the termination of their flight, or in striking and penetrating the target.

terminal velocity. The maximum velocity attainable, esp. by a freely falling body, under the given conditions;

specif., the maximum velocity an airplane can attain under the given conditions. If the term is not otherwise qualified, a vertical (zero-lift) dive path, normal gross weight, zero engine thrust, and standard sea-level air density are assumed.

terrestrial reference guidance. a type of missile guidance in which a device in the missile reacts to some property of the earth, such as magnetic effects, to keep the missile on a predetermined course.

test bed. 1. A base, mount, or frame within or upon which a piece of equipment, esp. an engine, is secured for testing. 2. A FLYING TEST BED.

test chamber. A place, section, or room having special characteristics where a person or object is subjected to experiment, such as an altitude chamber; specif., the test section of a wind tunnel. See TEST SECTION.

test club. Same as CLUB PROPELLER.

test flight. A flight to make controlled observations of the operation or performance of an aircraft or rocket, of an aircraft or rocket component, of a system, etc.

—test-fly, *verb tr.*

test pilot. A pilot who regularly makes test flights.

test section. The section of a wind tunnel where objects are tested to determine their aerodynamic characteristics. Also called a "test chamber" (which see).

test stand. A stationary platform or table, together with any testing apparatus attached thereto, for testing or proving engines, instruments, etc. See PROVING STAND.

tetrahedron, noun. An object having four sides or faces—applied to such an object used as a wind-direction indicator on an airdrome.

theodolite, noun. An optical instrument for accurately measuring horizontal, and, usually, vertical angles. See PHOTO THEODOLITE.

thermal, noun. A rising current of warm air. See CONVECTION CURRENT.

thermal barrier. A popular term for flight speed limitations imposed by aerodynamic heating. Also called the "heat barrier."

See AERODYNAMIC HEATING.

thermal efficiency. The efficiency with which a heat engine transforms the potential heat of its fuel into work or output, expressed as the ratio of the useful work done by the engine in a given time interval to the total heat energy contained in the fuel burned during the same time interval, both work and heat being expressed in the same units. See BRAKE THERMAL EFFICIENCY, INDICATED THERMAL EFFICIENCY.

thermal jet engine. A jet engine that utilizes heat to expand gases for rearward ejection. This is the usual form of aircraft jet engine.

thickness ratio. The ratio of the maximum thickness of an airfoil section to its chord length.

three-point landing. With airplanes so equipped, a landing in which the two main wheels and the tail wheel or tail skid touch the surface simultaneously.

throat, noun. The narrowest portion of a constricted duct, as in a diffuser, a venturi tube, etc.; specif., a NOZZLE THROAT.

throttle ice. Ice formed at or near the throttle of an engine from freezing of water vapor in air that has undergone an expansion.

through-flow combustion chamber. Same as STRAIGHT-FLOW COMBUSTION CHAMBER.

throw, noun. Specif., the displacement of a control surface from its neutral position; the amount of this displacement.

thrust, noun. 1. The forward-directed pushing or pulling force developed by an aircraft engine or a rocket engine.

See GROSS THRUST, JET THRUST, NET THRUST, PROPELLER THRUST, SPECIFIC THRUST, STATIC THRUST.

2. The force exerted in any direction by a fluid jet or by a powered screw, as, the *thrust* of an antitorque rotor. See REVERSE THRUST, ROTOR THRUST.

thrust augmentation. The increasing of the thrust of an engine or power plant, esp. of a jet engine and usually for a short period of time, over the thrust normally developed by the engine or power plant.

The principal methods of thrust augmentation are the introduction of additional air into the induction system, liquid injection, and afterburning. With a piston engine, "thrust augmentation" usually refers to the direction of exhaust gases so as to give additional thrust.

thrust augmenter. Any device used to increase the thrust of a piston, jet, or rocket engine, such as an afterburner. See AUGMENTER TUBE.

thrust axis. A line or axis through an aircraft, rocket, etc. along which the thrust acts; an axis through the longitudinal center of a jet or rocket engine, along which the thrust of the engine acts; a CENTER OF THRUST.

thrust face. Same as BLADE FACE.

thrust horsepower. 1. The actual amount of horsepower that an engine-propeller combination transforms into thrust. It is brake horsepower multiplied by propeller efficiency. 2. The thrust of a jet or rocket engine expressed in terms of horsepower. In this sense, thrust horsepower is proportional to the product of the thrust and the velocity of the free stream.

See EQUIVALENT SHAFT HORSEPOWER.

thrust horsepower specific fuel consumption. Specific fuel consumption based on thrust horsepower. See SPECIFIC FUEL CONSUMPTION and note.

thrust loading. The ratio of the gross weight of a jet or rocket-propelled aircraft or other vehicle to its thrust, expressed as the gross weight in pounds divided by the thrust in pounds. Cf. POWER LOADING.

thrust meter. An instrument for measuring static thrust, esp. of a jet engine or rocket. See REACTION BALANCE.

thrust power. The power usefully expended on thrust, equal to the thrust (or net thrust) times airspeed.

thrust reverser. A device or apparatus for reversing thrust, esp. of a jet engine. See REVERSE THRUST and note.

thrust specific fuel consumption. Specific fuel consumption based on thrust. See SPECIFIC FUEL CONSUMPTION and note.

tilting rotor. A rotor with blades free to flap as a unit (to rock or "seesaw") but not to drag. Sometimes called a "teetering rotor."

timed turn. A turn at a constant rate of change in heading held for a specific interval of time.

tip, noun. The outermost extremity of a wing, propeller blade, rotor blade, stabilizer, or other airfoil or blade; the end portion of an airfoil or blade.

tip diameter. Specif., the diameter of the rotor of an axial-flow compressor

at any given stage or of a turbine wheel, measured at the tips of its rotor blades. Cf. ROOT DIAMETER.

tip jet. A pressure jet at the tip of a rotor blade. See PRESSURE JET.

tip loss. A loss of lift at the tip of a wing or other surface, or a loss in performance, owing to the tip vortex.

tip-path plane. The plane in which the blade tips of a rotor rotate. Cf. PLANE OF ROTATION.

tipping, noun. PROPELLER TIPPING.

tip radius. Same as BLADE RADIUS.

tip shield. Same as END PLATE. Obs.

tip speed. The linear speed of the blade tip of a propeller or rotor or rotary-wing system; also, PERIPHERAL SPEED. Cf. PROPELLER SPEED, ROTOR SPEED.

tip-speed ratio. The ratio of the flow velocity in the plane of a rotor to the tip speed of the rotor.

tip stall. A stall (which see, sense 1a) at the tip of a wing or rotor blade, which in an airplane often results in rolling, yawing, and pitching and loss of effective aileron control.

tip tank, or tiptank, noun. Same as WING-TIP TANK.

tip vortex. A vortex springing from the tip of a wing, owing to the flow of air around the tip from the high-pressure region below the surface to the low-pressure region above it. See TRAILING VORTEX.

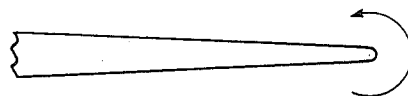

Illustrating tip vortex. Arrow indicates direction of flow from region of high pressure to region of low pressure. (Wing seen from trailing edge.)

to-from indicator. Same as SENSE INDICATOR.

ton-mile, noun. One ton carried one mile.

top camber. Same as UPPER CAMBER.

torque arms. A contrivance consisting of two metal arms hinged to one another at their ends, the free ends being attached to two parts, between which rotation is possible, to prevent rotation but to allow reciprocation.

torquemeter, noun. A meter for measuring torque, as in the shaft of an aircraft engine.

torque nose. A mechanism or apparatus at the nose section of an engine that senses the engine torque and activates a torquemeter.

torque stand. A test stand, together with torque-measuring equipment, on which an engine is mounted for static testing.

torsional flutter. Flutter involving oscillatory twisting in a wing or other airfoil.

total head. 1. The constant unit energy possessed by a fluid. At a given point in the fluid, the total head consists of the static pressure head, and the velocity head. See HEAD, sense 2. 2. Same as TOTAL PRESSURE.

total impulse. Same as IMPULSE—disting. from SPECIFIC IMPULSE.

total pressure. 1. Same as STAGNATION PRESSURE. 2. The pressure a moving fluid would have if it were brought to rest without losses. See TOTAL HEAD.

total-pressure tube. A tube for measuring the stagnation pressure of a fluid, i. e., a PITOT TUBE.

touch, verb intr. To touch down. To make contact between the landing gear of an aircraft and the ground, water, or other landing surface, either with or without completing the landing run and coming to a stop or remaining at rest, as, the pilot, or the airplane, touched down on the carrier deck.

touch-and-go landing. A landing in which the aircraft touches down but does not come to a stop before taking off again. See RUNNING TAKE-OFF, sense 2.

touchdown, noun. An act or instance of touching down. See TOUCH.

In compounds, such as touchdown area (where aircraft touch down), touchdown speed, etc.

tower, noun. Specif.: 1. A CONTROL TOWER. 2. A HELICOPTER TEST TOWER.

towing basin, or towing tank. A long, water-filled channel in which float and hull shapes are towed to study their hydrodynamic characteristics; the entire installation associated with this tank, including shed, towing carriage, offices, etc. A towing basin may include wave-making apparatus.

tow target. An aerial target towed, or designed to be towed, behind an aircraft. See AERIAL TARGET.

Tow targets include three main types: the banner target, consisting of a panel of some flexible material; the sleeve target, a

tubelike target distended with air when towed; and the winged target, a high-speed glider designed for target use.

track, noun. 1. The path or actual line of movement of an aircraft, rocket, etc. over the surface of the earth. It is the projection of the flight path on the surface. 2. The circular path described by a rotating propeller or rotor in proper alignment. 3. TREAD.

track, verb. 1. *tr.* To observe or plot the path of (something moving, such as an aircraft or rocket) by one means or another, as by telescope or by electronic devices—said of persons or of electronic equipment, as, the observer, or the radar, tracked the missile. 2. *intr.* Of an aircraft: To follow a desired track. 3. *intr.* Of a propeller or rotor or of its blades: To rotate in track. See TRACK, noun, sense 2.

tracker, noun. One who or that which tracks something.

track-type landing gear. A landing gear having endless belts running on bogies and rollers (as in a caterpillar tractor) instead of having wheels.

tractor, noun. 1. A TRACTOR AIRPLANE. 2. A TRACTOR PROPELLER.

tractor airplane. An airplane with its propeller or propellers forward of the center of gravity or lateral axis.

tractor engine. An engine fitted with a tractor propeller. Cf. PUSHER ENGINE.

tractor propeller. A propeller mounted at the forward end of an engine; a propeller mounted forward of the lateral axis or center of gravity of an aircraft. Cf. PUSHER PROPELLER.

traffic pattern. A prescribed pattern to be followed by aircraft in the air about an airdrome.

trailing edge. The aft edge of an airfoil, blade, etc., i. e., the edge over which the flow normally passes last. Cf. LEADING EDGE.

trailing-edge angle. The angle included between the two surfaces of an airfoil near the trailing edge. If the surfaces have curvature, the angle is commonly measured between straight lines tangent to the surface at ninety-eight percent chord.

trailing-edge flap. A flap, esp. a plain flap, installed at the rear of a wing. See PLAIN FLAP.

trailing vortex. A vortex that is shed from a wing or other lifting body and trailing behind it, esp. such a vortex

trailing from a wing tip (or from the end of a bound vortex).

trail rope. Same as DRAG ROPE.

trainer, noun. 1. An aircraft designed for training a person to fly. 2. A device used in flight training, i. e., a FLIGHT SIMULATOR (in sense 1).

transition point. Specif., a place in a field or flow, as in the boundary layer over an airfoil, where the flow changes from laminar to turbulent.

translational lift. The additional lift acting on a rotor owing to its translation through the air, as disting. from the lift existing in hovering.

transmissometer, noun. An apparatus that measures the transmission of light through the atmosphere, used esp. at the approach end of an airport runway to determine visibility.

transom, noun. A bulkhead at the stern or step of a float or hull.

transonic, adj. That occurs, or occurring, within a regime characterized by regions of both subsonic and supersonic flow, as in *transonic* flight, *transonic* flutter; that operates within this regime, as in *transonic* aircraft, *transonic* wing; characterized by transonic flow or transonic speed, as in *transonic* region, *transonic* zone.

transonic flow. Flow in which regions of both subsonic and supersonic velocities are present.

transonic speed. The speed of a body relative to the surrounding fluid at which the flow is in some places subsonic and in other places supersonic.

transpiration cooling. A process by which a body having a porous surface is cooled by forced flow of coolant fluid through the surface from the interior. Cf. FILM COOLING.

transponder, noun. A radar beacon consisting principally of an antenna, receiver, and transmitter, that emits signals only when triggered by the pulses of an interrogating radar set. This is the commonest kind of radar beacon.

transport, noun. A TRANSPORT AIRCRAFT.

transport aircraft. Aircraft, or an aircraft, designed to carry either people or cargo.

trans-sonic, or transsonic, adj. Same as TRANSONIC. *Rare.*

transverse acceleration. Acceleration in a direction transverse to the longitudinal axis of a body; specif.: a. A lateral acceleration of an aircraft,

rocket, etc. b. *Av. med.* An acceleration normal to the trunk of the human body. See BACK-TO-CHEST ACCELERATION, CHEST-TO-BACK ACCELERATION.

transverse axis. A LATERAL AXIS.

trap, noun. A part in a solid-propellant rocket motor that holds the grain in place.

tread, noun. The transverse distance between the longitudinal center lines of the main wheels, floats, etc. of a landing gear. Also called the "track."

tricycle landing gear. A landing gear comprising two wheels or sets of wheels laterally in line and a nose wheel unit.

trim, noun. 1. The condition of an airplane or other heavier-than-air aircraft in which it maintains a fixed attitude with respect to the wind axes, the moments about the aircraft's axes being in equilibrium. The word "trim" is often used with special reference to the balance of control forces. 2. The attitude of an airship with respect to the angle between its fore-and-aft axis and the horizontal. See DYNAMIC TRIM, FLYING TRIM, STATIC TRIM. 3. The attitude of a seaplane float or hull with respect to the surface of the water as a horizontal reference. 4. TRIM ANGLE.

—*in trim, out of trim.* In or out of a proper or desired condition of balance, etc.—said of any aircraft.

—*trim by the bow, trim by the stern.* In trim with the bow or stern down—said of an airship.

trim, verb. 1. *tr.* To put (an aircraft) into trim. 2. *tr.* To adjust (a tab, stabilizer, etc.) so as to bring an aircraft into trim. 3. *intr.* To enter trim.

trim angle. 1. a. The angle between an axis of an airplane or other heavier-than-air aircraft and a wind axis; esp., the angle between the longitudinal axis of such an aircraft and the longitudinal wind axis, projected to the plane of symmetry. b. The angle between the longitudinal axis of an airship and a horizontal plane. The angle is positive when the bow is higher than the stern. c. The angle between the horizontal and some specified reference line of a seaplane float or hull. This angle is positive when the bow is higher than the stern. 2. The tab angle of a trim tab.

trimming moment. 1. The moment about a reference point, usually the center of

gravity, exerted by a seaplane hull or float held at a fixed trim angle. This moment is considered positive when the bow tends to rise. 2. A pitching moment of an airship produced by fore-and-aft shifting of its center of gravity, of its center of buoyancy, or of both.

trimming tab. Same as TRIM TAB.

trimotor, noun. An airplane having three internal-combustion reciprocating engines.

—*trimotored, adj.*

trim speed. A speed at which an aircraft maintains a given trim.

trim tab. A tab (which see) that is deflected to a position where it remains to keep the aircraft in the desired trim. Also called a "trimming tab."

Some types of trim tabs can be set only by direct manual adjustment on the ground (fixed trim tab), while others may be adjusted from the cockpit or cabin while in flight (controllable trim tab).

trihibious, adj. [*Tri* + *amphibious*.] Specif., of an aircraft or landing gear: Capable of taking off from, or landing on, snow or ice, land, and water.

triplane, noun. A form of airplane, now generally obsolete, having triple-decked wings.

tropopause, noun. The upper boundary of the troposphere.

troposphere, noun. The lowest layer of the earth's atmosphere, characterized esp. by a relatively steady temperature lapse rate, varying humidity, and turbulence.

The troposphere meets the lower boundary of the stratosphere; hence, its thickness varies. See STRATOSPHERE, note.

true airspeed. a. Actual or exact airspeed. b. More usually, an airspeed measurement or value accepted as actual or exact airspeed, as determined from a series of corrections applied to the reading of an airspeed indicator, or as shown by a true airspeed indicator.

Various values of airspeed, having different degrees of accuracy, are called "true." Traditionally, the term has been applied to the airspeed value determined by the application to calibrated airspeed of corrections for temperature and pressure; latterly, corrections have also been applied for compression of the air and sometimes for other factors to find "true" airspeed.

true-airspeed indicator. An airspeed indicator designed to show acceptable values of true airspeed. Modern types

of true-airspeed indicators incorporate elements that automatically compensate for varying conditions.

true altitude. Altitude above mean sea level. Cf. ABSOLUTE ALTITUDE.

true bearing. Bearing measured relative to true north.

true course. A course measured relative to true north.

true heading. Heading measured relative to true north.

true north. The direction of the geographic north pole.

trunkline, noun. A major airline; a main air route.

tuck, verb intr. To tuck under or up. Of an airplane: To nose down or up at or near transonic speeds.

—*tuck under, tuck up.* An act or instance of tucking under or up, or a tendency to tuck under or up.

tuft study. A study of the airflow over an airfoil or other body made by attaching small clusters of yarn or other material to the surface of the body to indicate the local instantaneous direction of flow.

tumble, verb intr. To rotate end over end—said of a rocket, of an ejection capsule, etc.

tumble home. The curvature or inclination of the side of a float or hull toward the center line at the top.

tunnel, noun. A structure, installation, or facility incorporating apparatus to simulate flight conditions in one way or another, specially designed for testing or experimenting with powerplants, or with aircraft, rockets, or other aerodynamically designed bodies, engine installations, or models; specif., a WIND TUNNEL.

See FREE-FLIGHT TUNNEL, GUST TUNNEL, SPIN TUNNEL, WATER TUNNEL.

tunnel axis. Any one of the geometrical axes of a wind tunnel. See AXIS, sense 2 and note.

turbine, noun. 1. A machine consisting principally of one or more turbine wheels and a stator. See TURBINE WHEEL. 2. A turbine wheel. 3. A TURBINE ENGINE.

See BLOWDOWN TURBINE, EXPLOSION TURBINE, FREE TURBINE, GAS TURBINE, IMPULSE TURBINE, PARTIAL-ADMISSION TURBINE, REACTION TURBINE, SINGLE-STAGE TURBINE.

turbine blade. Any one of the blades of a turbine wheel.

turbine engine. An engine incorporating a turbine as a principal component; esp., a GAS-TURBINE ENGINE.

turbine nozzle. Any one of the nozzles that directs a fluid onto a turbine wheel, as in a gas-turbine engine. See NOZZLE DIAPHRAM.

turbine wheel. A multivaned wheel or rotor, esp. in a gas-turbine engine, rotated by the impulse from or reaction to a fluid passing across the vanes. Often called a "turbine" (which see).

turbo, *noun.* 1. Short for TURBOSUPERCHARGER. 2. As an attributive in compounds, a TURBINE (in senses 1 or 2), as in *turbo case*, *turbo unit*.

turbo-, *combining form.* a. Incorporating a turbine, as in *turbo compound* (engine). b. Turbine-driven, as in *turbo-compressor*, *turbogenerator*, *turbo-pump*.

turbo-boost selector. A manually operated control for an electronic-mechanical apparatus by means of which manifold pressure is controlled in a turbosupercharged power plant.

turbofan, *noun.* 1. An aircraft gas-turbine engine of the bypass or ducted-fan type. See BYPASS ENGINE, DUCTED FAN, sense 2. 2. A turbine-driven fan.

turbojet, *noun.* A TURBOJET ENGINE.

turbojet engine. A jet engine incorporating a turbine-driven air compressor to take in and compress the air for the combustion of fuel (or for heating by a nuclear reactor), the gases of combustion (or the heated air) being used both to rotate the turbine and to create a thrust-producing jet. Often called a "turbojet." See JET ENGINE, sense 2, NUCLEAR TURBOJET.

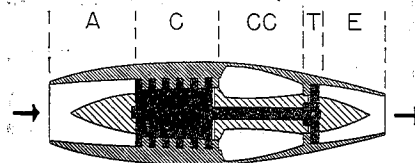

Turbojet engine (simplified axial-flow type). (Arrows indicate flow direction.) A air-inlet section; C compressor; CC combustion chambers; T turbine; E exhaust section.

turbomachine, *noun.* An apparatus incorporating a turbine as a principal component, such as a turbojet engine, a turbopump, a turbogenerator, etc.

—**turbomachinery,** *noun.*

turboprop, *noun.* Same as TURBOPROPELLER ENGINE.

turbopropeller, *noun.* 1. A propeller designed esp. for use with a turbopropeller engine. 2. A TURBOPROPELLER ENGINE. *Rare.*

turbopropeller engine. An aircraft engine of the gas-turbine type (see GAS-TURBINE ENGINE) in which the turbine power is used to drive both a compressor and a propeller. This type of engine usually delivers jet thrust in addition to its propeller thrust. Often called a "turboprop" or "turboprop engine"; sometimes called a "propeller turbine" or "propeller-turbine engine." See PROPJET ENGINE.

turboprop engine. Same as TURBOPROPELLER ENGINE.

turboramjet, *noun.* A TURBORAMJET ENGINE.

turboramjet engine. A name applied to a turbojet with an afterburner (which see) attached.

turbosupercharger, *noun.* A supercharger incorporating a turbine driven by exhaust gases from the engine to rotate the impeller.

turbulence, *noun.* An agitated condition of the air or other fluid; a disordered, irregular, mixing motion of a fluid or fluid flow, as about a body in motion through the air, as in an air compressor, in combustion gases, etc.; technically, a condition of fluid flow characterized by fluctuations of velocity random in magnitude and direction. See CLEAR-AIR TURBULENCE.

turbulence factor. A factor representing the degree of turbulence in a wind tunnel. It is used to determine the effective Reynolds number. See EFFECTIVE REYNOLDS NUMBER.

turbulent boundary layer. A boundary layer characterized by random fluctuations of velocity and by pronounced lateral mixing of the fluid. See TURBULENCE.

turbulent flow. A flow characterized by turbulence, i. e., an irregular, eddying, fluctuating flow; technically, a flow in which the velocity at a given point varies erratically in magnitude and direction with time—often disting. from LAMINAR FLOW.

turn, *noun.* 1. An act or instance of changing horizontal direction, usually by a maneuver in a substantially horizontal plane. See PROCEDURE TURN,

STANDARD RATE TURN, TIMED TURN, and cf. IMMELMAN. 2. One complete rotation in a spin, as, recovery was made within two turns.

turn-and-bank indicator. A flight instrument that combines a bank indicator and a turn indicator in the same housing. Also called a "bank-and-turn indicator." See BANK INDICATOR, TURN INDICATOR.

turn indicator. A flight instrument, commonly gyroscopic, that indicates the direction of turn and rate of turn of an aircraft. It is commonly combined with the bank indicator in the turn-and-bank indicator.

turnmeter, *noun.* An instrument for measuring the rate of rotation of an aircraft or other flying vehicle about a given axis.

turret, *noun.* A dome-like, rotatable structure, usually transparent, on an aircraft, within which guns are mounted. See BALL TURRET.

turtleback, *noun.* The rounded back of certain airplane fuselages, esp. of the fuselage of certain light planes, sometimes a detachable fairing, beginning aft of the cockpit or cabin and extending to the tail.

twin-engine, or twin-engined, *adj.* Of aircraft: Having two engines, as in *twin-engine jet fighter*; specif., without a qualifying word, having two internal-combustion reciprocating engines, as in *twin-engine fighter*, *twin-engined aircraft*. Cf. TWIN-JET.

twin-jet, *adj.* Of aircraft: Having two jet engines, as in *twin-jet fighter*, *twin-jet transport*.

twist, *noun.* The configuration of an airfoil, such as a wing or propeller blade, having varying angles of attack or varying blade angles along its span or length, as if torsion were applied about the spanwise axis. Twist of a

ullage, *noun.* The amount that a container, such as a fuel tank, lacks of being full.

ultimate load. 1. A load that causes, or is calculated to cause, destructive failure of a structural member or part. 2. AN ALLOWABLE LOAD.

wing is positive with washin, negative with washout.

See AERODYNAMIC TWIST, GEOMETRIC TWIST, LINEAR TWIST, UNIFORM TWIST. See also WASHIN, WASHOUT.

two-control, *adj.* Having, or performed with, only two of the three conventional controls of an aircraft, e. g., ailerons and elevators but no rudder, as in *two-control airplane*, *two-control operation*.

An aircraft with ruddervators is not considered to be "two-control."

two-cycle engine. A TWO-STROKE-CYCLE ENGINE.

two-dimensional flow. Flow that is observed, analyzed, or considered as if there were no component of flow normal to the longitudinal plane being studied, the flow in other parallel planes being considered identical.

two-dimensional ramjet. A type of ramjet having two sides of its duct or passage parallel, designed esp. to be installed or incorporated within an airfoil, such as a rotor blade.

2N class. A class of Goodyear dirigibles having a volume of 975,000 cubic feet.

two-place, *adj.* Having places for two persons, as in *two-place biplane*, *two-place helicopter*. See PLACE.

two seater. An aircraft having two seats. See SEAT, SEATER.

two-stage rocket. A rocket having two propulsion units, one behind the other, the forward unit firing after the rear rocket has exhausted its propellant and been jettisoned. Also called a **two-step rocket**.

two-stroke-cycle engine. An internal-combustion reciprocating engine having a cycle of operations within the cylinder consisting of two strokes of the piston, each upward stroke of the piston being a compression stroke and each downward stroke being a power stroke.

U

ultrasonic, *adj.* 1. *Acoustics.* Of or pertaining to frequencies above those that affect the human ear, i. e., more than 20,000 vibrations per second. 2. Of or pertaining to very high supersonic speeds; hypersonic. *Rare.*

uncontrolled mosaic. A mosaic assembled without correction for distortion

of any kind, and so containing errors in scale.

undercarriage, noun. The landing gear of an aircraft. *Chiefly British.* See LANDING GEAR.

undershoot, noun. An act or instance of undershooting, as, he made an undershoot.

undershoot, verb. 1. *tr.* To fall short of (a mark or place) upon which a landing is intended. 2. *intr.* Of an aircraft or persons within: To perform an action as indicated in sense 1.

unfeather, verb tr. To turn (a propeller) from the feathered position.

unidirectional, adj. That goes or transmits in one direction only, as in *unidirectional* channel, *unidirectional* pulse.

uniform flow. An idealized flow in which the streamlines are parallel and the velocity is constant throughout.

uniform twist. A twist of an airfoil such that the corresponding points of all sections lie in a straight line.

unit injector. A fuel-injection assembly for a compression-ignition engine comprising a pump and an injector in a single unit, one of which is used on each cylinder of the engine.

unstable oscillation. Oscillation whose amplitude increases.

unsteady flow. A flow whose velocity components vary with time at any point in the fluid. Unsteady flow is of *fixed pattern* if the velocity at any point changes in magnitude but not direction, and of *variable pattern* if the velocity at any point changes in direction.

unsymmetrical loading. A loading condition of an airplane in which the load

is unequally distributed on each side of the plane of symmetry, as in a roll.

updraft, noun. *Meteorol.* A draft (in sense 1, which see) moving upward.

uplock, noun. A locking device to hold a retracted landing gear in place.

upper atmosphere. The atmosphere at a high altitude.

This is an elastic term. Depending upon context, it may refer to the atmosphere above 25,000 feet or a higher level. In 1909, for example, the term was used to refer to the atmosphere above the tropopause; more recently it has been used in reference to the atmosphere above a higher level (e. g., 65,000 feet). Among biologists, the tendency is to make little or no distinction between the upper atmosphere and space.

upper camber. The camber of the upper side of an airfoil. Also called "top camber."

upper-surface aileron. An aileron hinged to the upper surface of an airfoil and which deflects only upward from its neutral position.

upwash, noun. A flow deflected upward by a wing, rotor, rotor blade, etc. Cf. DOWNWASH.

upwash angle. A negative downwash angle, i. e., the acute angle, measured in a plane parallel to the plane of symmetry of an aircraft, between the direction of upwash and the direction of the undisturbed airstream. Cf. DOWNWASH ANGLE.

useful load. 1. The entire load put aboard an aircraft, including fuel, oil, crew, passengers, mail, cargo, armament, etc.; the amount of this load, measured in pounds, equal to the difference between the gross weight and the empty weight of the aircraft. 2. A PAYLOAD. *Rare.*

pulses or signals that are transmitted to the control system to stabilize the aircraft. b. A fin or stabilizer on a bomb, aircraft, or the like; a fixed or movable surface used to control or give stability to a rocket. See CONTROL VANE, HYDROVANE. 2. A blade or paddlelike object, often fashioned like an airfoil and usually one of several, that rotates about an axis, either being moved by a flow or creating a flow itself, such as the blade of a turbine, of a fan, of a rotary pump or air compressor, etc. See IMPELLER VANE. 3. *Also* guide vane. Any of certain stationary blades, plates, or the like that serve to guide or direct a flow, or to create a special kind of flow, as: a. Any of the blades in the nozzle ring of a gas-turbine engine. b. Any of the plates or slatlike objects that guide the flow in a wind tunnel. c. A plate or "fence" projecting from a wing to prevent spanwise flow. See CONTRA-VANE.

See AIRFOIL and note.

vane-type supercharger. A type of supercharger in which an eccentrically located rotor equipped with one or more sliding vanes catches the air mixture at the intake side of its housing and forces it around to and through the outlet side.

This supercharger is of the positive-displacement kind. See POSITIVE-DISPLACEMENT COMPRESSOR.

vapor lock. A stoppage or diminution of fuel flow in a system caused by fuel vapor in the lines. See AIR LOCK.

vapor pressure. The pressure exerted by a vapor, such as the pressure exerted by oxygen vapor in a tank of liquid oxygen; specif., *Meteorol.*, the partial pressure of water vapor in the atmosphere.

vapor trail. Specif., same as CONDENSATION TRAIL.

variable-area exhaust nozzle. On a jet engine, an exhaust nozzle of which the exhaust exit opening can be varied in area by means of some mechanical device, permitting variation in the jet velocity. Cf. FIXED-AREA EXHAUST NOZZLE.

variable-density wind tunnel. A wind tunnel in which the pressure of the working fluid can be increased so as

to make the flow about a test model more closely simulate that of the flow about the full-scale object.

variable-pitch propeller. A propeller whose pitch may be changed, esp. such a propeller whose pitch may be changed while the propeller is rotating, such as an automatic propeller, a controllable-pitch propeller, etc.

variometer, noun. Specif., same as RATE-OF-CLIMB INDICATOR. *Rare.*

vee, noun. Another writing of "V." See V.

vehicle, noun. Specif., a structure, machine, or device, such as an aircraft or rocket, designed to carry a burden through air or space; more restrictively, a rocket craft or missile.

This word has acquired its specific meaning owing to the need for a term to embrace aircraft, rockets, and all other flying craft, and has more currency than other words used in this meaning. See CRAFT, sense 2 and note, MACHINE and note.

Usage of "vehicle" in the senses given above is seldom ambiguous, but where necessary the word may be modified, as in *air vehicle*, *flying vehicle*.

velocity, noun. 1. Speed. See note. 2. A vector quantity equal to speed in a given direction.

In sense 1, "velocity" is often used synonymously with "speed," as in "the velocity of the airplane," but in such contexts "speed" is properly the preferred term; except in the compound "airspeed," "velocity" is preferred to "speed" in reference to the motion of air or other fluid.

velocity head. The unit energy of a fluid stream owing to its motion. See HEAD, sense 2.

velocity of sound. See SONIC SPEED.

velocity potential. In irrotational flow, a quantity whose rate of change with distance in any direction equals the flow velocity in that direction.

velocity profile. A graphic representation of the variation of the velocity in a field of flow with displacement normal to the general flow direction.

venetian-blind flap. A type of slotted flap consisting of a number of slats fastened together in a ladderlike or venetian-blind arrangement.

V-engine, noun. An internal-combustion reciprocating engine with its cylinders so disposed about the crankshaft that they form, in an end view of the engine, the letter "V."

vent, noun. An opening for the passage of fluid.

See FUEL-TANK VENT, OIL-TANK VENT, PARACHUTE VENT.

V

V, noun. Something shaped like, or suggesting, the letter V, such as a formation of aircraft, an engine, etc. Also written "vee."

valve, verb tr. Specif., to release (gas) from a balloon, airship, or gas cell by means of a valve.

valve lap. Same as VALVE OVERLAP.

valveless pulsejet. A pulsejet that operates without any intake valves. See PULSEJET ENGINE, note.

valve overlap. A condition in which the intake and exhaust valves in an engine cylinder are open simultaneously. Sometimes called "valve lap."

vane, noun. 1. A thin and more or less flat object intended to align itself with a stream or flow in a manner similar to that of the common weathercock, as: a. A device that projects ahead of an aircraft to sense gusts or other actions of the air so as to create im-

ventral, adj. Mounted on, or belonging to, the belly (which see) or underside of an aircraft, as in *ventral* air scoop, *ventral* fin, *ventral* radome. Cf. DORSAL.

venturi, noun. [Sometimes capitalized.] A converging-diverging passage for fluid, which increases the fluid velocity and lowers its pressure; a VENTURI TUBE.

See BOOST VENTURI.

venturi tube. [After G. B. Venturi (1746-1822). Sometimes capitalized (Venturi tube).] A tube or pipe having a converging-diverging passage which increases the velocity and decreases the pressure of fluid flowing through it, in accordance with Bernoulli's law. See BERNOULLI'S LAW.

The venturi tube has various applications, such as for driving suction-operated aircraft instruments. It has also been used in airspeed measurement.

vertical, adj. In specific senses: 1. Of flight, or of flight maneuvers: Made or occurring in a line or plane perpendicular to the horizontal plane, as in *vertical* climb, *vertical* dive, *vertical* take-off. See VERTICAL BANK. 2. Directed or acting in a line perpendicular to the horizontal plane, as in *vertical* (esp. upward) lift.

vertical acceleration. Acceleration in a vertical direction; acceleration substantially along the vertical axis of an aircraft, rocket, etc.

vertical aerial photograph. An aerial photograph made with the optical axis of the camera vertical or substantially so.

vertical axis. An axis passing through an aircraft from top to bottom and usually passing through the center of gravity. Also called a "normal axis." See AXIS, sense 2 and note, YAW AXIS.

vertical bank. A bank in which the lateral axis of the aircraft is perpendicular, or substantially so, to the horizontal plane.

vertical fin. A vertical stabilizer on an airplane or airship. See VERTICAL STABILIZER.

vertical reversal. A maneuver or stunt in which an airplane is snarled from a steep bank in one direction to a steep bank in the other direction, reversing its original direction of flight. Sometimes called a "cartwheel."

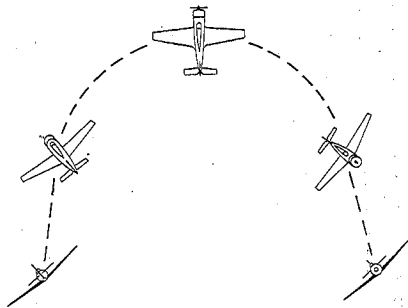

Vertical reversal.

vertical-speed indicator. A RATE-OF-CLIMB INDICATOR.

vertical stabilizer. A fin mounted approximately parallel to the plane of symmetry of an airplane, airship, or other aircraft, to which the rudder, when present, is attached. Also called a "vertical fin" (which see). Cf. HORIZONTAL STABILIZER.

vertical tail. A vertical, or substantially vertical, component of an aircraft's stabilizing and controlling surfaces, in most forms comprising both a fixed surface (vertical stabilizer) and a movable surface (rudder).

vertical tail area. The area contained within the outline of a vertical tail, the area of any fairings or fillets extending beyond this outline being ignored.

vertical take-off and landing. The full term for "VTOL" (which see).

vertiplane, or vertoplane, noun. A fixed-wing VTOL aircraft.

This term is not yet stabilized.

VFR—Abbreviation for *Visual Flight Rules*—also used as an adjective or adverb, as in *VFR* flight, or as, to fly *VFR*.

V-G recorder. [Velocity-Gravity.] An instrument that records speed and the acceleration along one or more of the principal axes of an aircraft or other flying vehicle.

virtual mass. The actual mass of a body, plus its apparent additional mass. See APPARENT ADDITIONAL MASS.

viscous drag. Drag owing to viscosity; FRICTION DRAG.

visibility, noun. 1. The range of vision within which prominent objects can be distinguished, depending upon the con-

dition of the atmosphere and illumination, as, *visibility* was good; in determining and reporting weather conditions, the horizontal distance to which good vision is possible, as, *visibility* is ten miles—disting. from ceiling (which see, sense 4). 2. The characteristic of an aircraft that governs the ability to see from within it, as, the short nose gives the plane excellent forward *visibility*; this characteristic as modified by the given conditions, as, ice on the windshield reduces *visibility*. 3. The range of vision at a particular place—scribed to the place, as, the airport had a *visibility* of two miles. 4. The ability of a person to see under a given situation, as, the pilot had limited *visibility*.

visual-aural radio range. A type of very-high-frequency four-course radio range in which two of the courses are identified by aural presentation and the other two by a visual indicator.

visual flight. Flight in which the pilot uses his vision directly, rather than instruments, to determine attitude, position with respect to other objects, etc.

Certain instruments, such as the altimeter, airspeed indicator, compass, etc., are used in visual flight.

Visual Flight Rules. [Sometimes, though rarely, not capitalized.] Rules specified by qualified authority establishing minimum flying altitudes and limits of visibility to govern visual flight.

volplane, verb intr. To glide or soar. Rare.

volumetric efficiency. Of an internal-combustion piston engine, the efficiency with which the engine draws the fuel-air mixture into its cylinders, expressed, e. g., as the ratio of the volume of the fuel-air mixture drawn in at inlet pressure and temperature to the piston displacement.

vortex, noun. A mass of fluid, such as air, in circulating motion; also, a VORTEX FILAMENT or VORTEX LINE.

See BOUND VORTEX, HORSESHOE VORTEX, STARTING VORTEX, TIP VORTEX, TRAILING VORTEX.

vortex filament. In the mathematical description of three-dimensional flow, a line through the center of rotation of a system of circulatory flow, where the path traveled by circulating fluid

particles is infinitesimal and the velocity of the particles is infinite, the line having the strength of the circulation around it. Sometimes called a "vortex line."

The vortex filament is sometimes physically described as a rotating cylindrical region through the core of a circulating system, having finite radius and finite angular velocity.

vortex line. 1. A VORTEX FILAMENT. 2. A line through a system of circulatory flow, tangent at every point to the axis of rotation of the flow.

vortex ring. 1. A recirculating flow that occurs through a rotary-wing system at certain rates of vertical or near-vertical descent, marked by increased stress and vibration and control difficulties. 2. A system of vortices consisting of a horseshoe vortex whose ends are connected by a starting vortex. Rare. See STARTING VORTEX, note.

vortex sheet. In a fluid medium, a thin layer composed of a large number of vortex lines shed at the trailing edge of an airfoil, substantially perpendicular to the span, across which layer occurs a discontinuity in the tangential component of the flow velocity.

In the case of a propeller or rotor, the vortex sheet is helicoidal.

vortex street. A KÁRMÁN VORTEX STREET. **ville, noun.** [French; italicized in English context.] A spin. Obs. and rare in English.

V-struts, noun. A pair of struts, usually interplane struts, arranged like the letter "V."

V-tail, noun. Same as BUTTERFLY TAIL. **VTO, or, sometimes, V. T. O., noun.** A VTOL.

VTOL, or, rarely, V. T. O. L.—Abbreviation for *vertical take-off and landing*—pronounced by letter and also used: (1) as an attributive adjective designating heavier-than-air aircraft capable of taking off and landing vertically (while a helicopter, strictly speaking, is a VTOL aircraft, the term usually refers to an aircraft other than a helicopter having this capability) and (2) as a noun meaning a heavier-than-air aircraft that can take off and land vertically, as, this VTOL is easy to fly. See TAIL SITTER.

Usage of the term "VTOL" is not yet completely stabilized.

W

waist, noun. The middle part, longitudinally, of an airplane fuselage, esp. that of a bomber.

waist, verb tr. To narrow or "pinch in" (a fuselage or other body) at or near the middle.

wake, noun. The trail or region of disturbed fluid behind a body moving through the fluid. Cf. WASH, *noun*.

walk, verb tr. 1. To walk the rudder. To push first on one rudder pedal (or one side of the rudder bar) then the other, swinging the rudder from side to side. 2. To walk a wing. To walk along the wing of an aircraft in flight, sometimes also performing headstands or other stunts.

walkway, noun. A footway, as along a wing root, in or across the top of an airship, etc.; a CATWALK.

wall, noun. 1. The inside wall of a wind tunnel, esp. at the test section. 2. A FIRE WALL.

In compounds in sense 1, such as wall correction (a correction for wall effect, the effect on the flow around a tested object, owing to the interference of the wall with the flow).

war emergency power. The maximum power or thrust that a military aircraft engine can develop without damage for a brief period of time as specified by qualified authority.

warhead, noun. That part or section of a missile (such as a guided rocket missile) containing an explosive or other substance or device intended to inflict damage on an enemy.

warm, verb tr. To warm up. To run (an aircraft engine) with the aircraft unmoving in order to heat the engine to operating temperature. Also, infrequently, *intr.* Cf. RUN, *verb*.

warm-up, noun. An act or instance of warming an engine up.

warp, verb tr. 1. To twist, or to give twist to (an airfoil, esp. a wing). On certain early airplanes, the wings were warped at will to perform the function now performed by ailerons. See TWIST. 2. To haul (an airship) into its dock. See DOCK, *verb*.

warplane, noun. An airplane designed for combat, such as a fighter or bomber.

Warren truss. [After one Captain Warren (English), who adapted the type for bridges from a Belgian design.] A rigid fuselage truss having diagonal braces between the longerons.

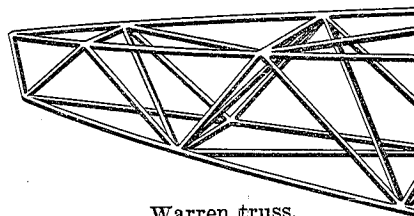

Warren truss.

wash, noun. The disturbed air or fluid produced by the passage of a body.

See DOWNWASH, PROPELLER WASH, SIDE-WASH, UPWASH, and cf. WAKE.

wash, verb tr. To wash (a wing) in or out. To give washin or washout to a wing.

washin, noun. A permanent warp or twist given a wing such that some specified or understood angle of attack (usually the geometric angle of attack) is greater at the tip than at the root. See WASHOUT and note.

washout, noun. A permanent warp or twist given a wing such that some specified or understood angle of attack (usually the geometric angle of attack) is smaller at the tip than at the root.

Washout and washin (which see) are sometimes given to opposite wings on an airplane to counteract engine torque; washout is often given a wing to improve stalling characteristics.

Washout (and washin) are sometimes specified as *aerodynamic*, if the absolute angle of attack varies between root and tip, or *geometric*, if there is variation in the geometric angle of attack between root and tip.

waste gate. A valve by means of which a turbosupercharger is controlled, exhaust gases in excess of the amount required being diverted through the valve and into the open before reaching the turbine. Also called a "blast gate."

water-based, adj. Of aircraft: That float, take off, and land on water.

water-cooled, adj. Cooled by water, as in *water-cooled engine*, *water-cooled turbine*, etc.

water injection. The introduction of water into the induction system of an engine to mix with the fuel and air and increase the power or thrust by cooling or by increasing the mass flow of exhaust gases.

water lane. A lane or strip of water marked or set aside and maintained for the take-off and landing of seaplanes.

water line. A fore-and-aft line on a seaplane float or hull, parallel to the base line, coincident with the water level with the seaplane on an even keel under a given load. See LOAD WATER LINE.

water loop. A violent, whirling turn of a seaplane while moving over the water. Cf. GROUND LOOP, sense 1.

water recovery. Specif., the reclaiming of water from engine exhaust gases by condensation, formerly used on airships to compensate for the weight of fuel consumed.

water rudder. A hydroflap for guiding a seaplane on the water.

water ski. A HYDROSKI. *Rare.*

water tunnel. An apparatus or installation similar to a wind tunnel, but using water as the working fluid and used in aerodynamic research.

Like a wind tunnel, a water tunnel may have an open throat or a closed throat.

wave, noun. Specif., a surface or layer of discontinuity (i. e., of abrupt changes in conditions, as in pressure, velocity, temperature, etc.) in a fluid medium.

See COMBUSTION WAVE, COMPRESSION WAVE, DETONATION WAVE, EXPANSION WAVE, REFLECTED WAVE, sense 1, SHOCK WAVE.

wave drag. Drag owing to the variation of entropy and velocity through a shock wave, with consequent variation of momentum in the mass flow of air. Also called "shock drag."

wave-off, noun. Also, less frequently,

waveoff. 1. An act or instance of refusing an aircraft permission to land in an approach, necessitating another attempt; the signal given an aircraft in such refusal; also, an instance of being denied permission to land in an approach. 2. The period of flight following the refusal to land in an approach—sometimes given specific definition in this sense.

weathercock, verb intr. Of an aircraft, a rocket, etc., esp. of an airplane: To

head into the wind, or tend to head into the wind.

—*weathercocking, noun.*

weathercock stability. Same as DIRECTIONAL STABILITY.

weather-vane, verb intr. Same as WEATHERCOCK.

weave, noun. A slow (long-period) waving or bending backward and forward of propeller blades when rotating.

web, noun. 1. Rocketry. The wall of a pierced grain of propellant. 2. A LIFT WEB.

weight per horsepower. The ENGINE WEIGHT PER HORSEPOWER.

well, noun. AN ACCELERATING WELL OR A WHEEL WELL.

W-engine, noun. An internal-combustion reciprocating engine with three banks of cylinders so disposed about the crankshaft that they form, in an end view of the engine, a shape suggesting the letter "W." Also called an "arrow engine."

wet, verb tr. To come in contact with, and flow across (a surface, body, or area)—said of air or other fluid.

wheel, noun. Specif., a CONTROL WHEEL OR TURBINE WHEEL.

wheel well. A recess or hollow in a wing, fuselage, etc. for a retractable landing-gear wheel.

whip stall. A kind of stall, sometimes performed intentionally, in which the airplane first goes into a stall in a steep nose-up attitude, then turns sharply, or "whips," into a steep nose-down attitude.

whip-stall, verb tr. and intr. To put into, or to make, a whip stall.

whirlybird, noun. A helicopter. *Slang.*

wick, noun. Specif., a STATIC DISCHARGER.

winch suspension. The rigging on a kite balloon that is attached to the cable that leads to a winch on the ground.

wind, noun. Air, or a body of air, in motion, esp. in a substantially horizontal flow. See RELATIVE WIND and cf. AIR CURRENT.

wind axis. Any one of a system of mutually perpendicular reference axes established with respect to the undisturbed wind direction about an aircraft or similar body. See AXIS, sense 2 and note.

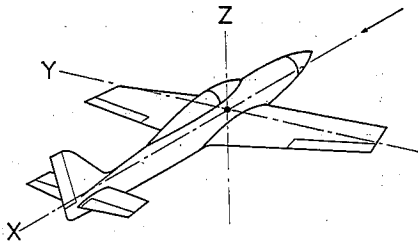

Wind axes. (Arrow shows wind direction.)

wind cone. Same as WIND SOCK.
wind direction. The direction from which a wind blows.

wind drift. Drift (which see, sense 1) caused by wind.

wind indicator. A device, such as a wind sock or wind tee, that shows the direction of the surface wind.

A wind indicator may sometimes include an anemometer.

windmill, noun. 1. A wind-driven screw used, e. g., to drive an electrical generator or an air log. 2. An autogyro rotor.

windmill, verb intr. To rotate from the force of a passing airstream without engine power—said of a propeller, of the rotor of an autogyro, helicopter, or the like, of a turbojet rotor, etc. Cf. AUTOROTATE, sense 1.

wind resistance. AIR RESISTANCE.

wind rose. 1. A diagram that shows, by means of radial lines, the relative frequency and average strength of winds from different directions at a given place and altitude and during a specified time of year. 2. A diagram showing the average relation between wind direction and allied meteorological phenomena.

winds aloft. Winds at high altitudes, unaffected by surface features; the direction and speed of such winds.

In compounds, usually without the hyphen, such as winds aloft chart, winds aloft report, etc.

wind sock. A tapered fabric sleeve mounted so as to catch and swing with the wind, thus showing the wind direction. Also called a "wind cone."

wind tee. A weather vane shaped like the letter "T" or like an airplane, located on an airdrome or landing area to show the wind direction to flying aircraft. Also called a "landing tee."

wind tunnel. A tubelike structure or passage, sometimes continuous (see TUNNEL), together with its adjuncts, in which a high-speed wind is produced, as by a fan, and within which objects such as engines or aircraft, airfoils, rockets (or models of these objects), etc. are placed to investigate the airflow about them and the aerodynamic forces acting upon them.

See ALTITUDE WIND TUNNEL, BLOWDOWN WIND TUNNEL, CLOSED-CIRCUIT WIND TUNNEL, CLOSED-THROAT WIND TUNNEL, INDRAFT WIND TUNNEL, INDUCTION WIND TUNNEL, INTERMITTENT WIND TUNNEL, OPEN-CIRCUIT WIND TUNNEL, OPEN-THROAT WIND TUNNEL, SHOCK TUBE, VARIABLE-DENSITY WIND TUNNEL.

This term occurs frequently in compounds, mostly self-explanatory, such as wind-tunnel model, wind-tunnel operator, wind-tunnel test, etc.

The first wind tunnel was built by Francis Herbert Wenham (1824-1908) for the Aeronautical Society of Great Britain in the 1870's; subsequently, pioneer wind tunnels were built and used by Nikolai Joukowski, Hiram Maxim, Gustave Eiffel, the Wright brothers, and other early experimenters.

wind-tunnel balance. A device or apparatus that measures the aerodynamic forces and moments acting upon a body tested in a wind tunnel.

wing, noun. 1. An airfoil that provides, or that is designed to provide, sustentation for an airplane, either (a) extending on either side of the airplane, separated from its mate by the fuselage or hull (thus a monoplane so constructed is said to have "wings"), but sometimes with both wings considered as a single unit, or (b) extending uninterruptedly on both sides of the airplane (e. g., as on a parasol monoplane). 2. A rotor blade on a helicopter, autogyro, or the like. 3. A model or facsimile of a wing for testing in a wind tunnel. 4. An AF organization immediately superior to a group. 5. *In plural.* An emblem resembling a bird's wings worn by an aircrew member, esp. such an emblem worn by a pilot.

For wings of various planforms, see ARROWHEAD WING, CLIPPED WING, CRANKED WING, CRESCENT WING, DELTA WING, DIAMOND WING, DOUBLE-DELTA WING, M WING, STRAIGHT WING, SWEET WING, W WING.

"Wing" is used in numerous compounds, such as wing chord, wing dihedral, wing fence, wing fillet, wing flap, wing lift, wing trailing edge, etc. (See the second element of these compounds, e. g., for wing chord see CHORD, etc.)

wing area. The area within the outline of the projection of a wing on the plane of its chords (the wing in this case considered as a unit, extending

on both sides of the airplane), including that area lying within the fuselage, hull, or nacelles.

With more or less conventional wings, the area blanketed by the fuselage or hull is determined by lateral lines connecting the leading and trailing edges of the half wings on either side, fairings and fillets being ignored; with a swept wing, the area within the fuselage or hull is contained within lines having the same angles of sweep as the leading and trailing edges. The wing area of a semispan model in a wind tunnel includes its image area (i. e., the area of the semispan model is doubled).

Unless otherwise stated, wing area includes the area of the ailerons; a deflected extensible flap is considered to increase the wing area.

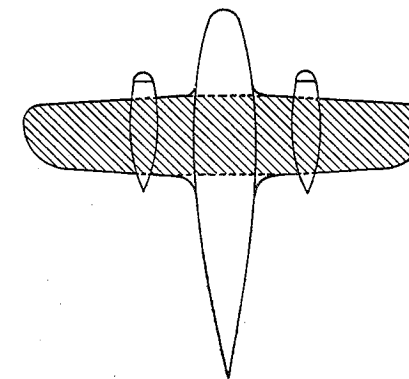
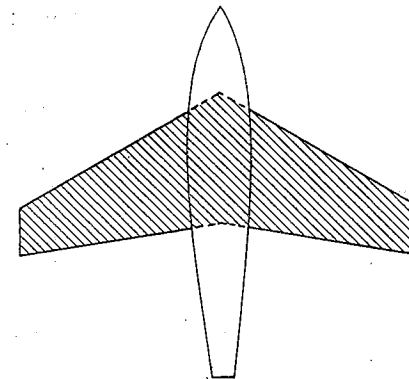

Wing area.

wing axis. The aerodynamic axis of a wing.

wing bow. Same as WING-TIP BOW.

wing car. Same as SIDE CAR.

wing cell. On a biplane or other multiplane, the complete assembly of wings

and trussing on one side of the fuselage or between nacelles where appropriate.

wing drag. That part of the total drag on an aircraft arising from the reaction of the air with its wing or wings, including profile drag and the drag due to lift. Where appropriate, the parasite drag of components attached to the wing is also included.

wingheavy, adj. Having a tendency to lower one wing or the other.

wing incidence. The ANGLE OF WING SETTING.

wing loading. The ratio of the gross weight of an airplane to the total planform area of its wing or wings. Cf. BLADE LOADING.

wing-over, noun. An airplane maneuver in which the airplane makes a steep zooming climb then banks and turns in the vertical plane into a dive or glide from which recovery is made at approximately the original altitude and in a direction opposite to the original direction. In some forms of the wing-over the airplane may be brought to a stall, or almost to a stall, in the zoom. See HAMMERHEAD STALL and REVERSEMENT.

wing panel. Any readily identifiable section of an airplane wing; a wing on either side of an airplane's fuselage or hull.

wing profile. The outline or form of a wing cross section. See WING SECTION, sense 1.

wing root. The base of a wing, where it joins the fuselage or other main body of the airplane.

wing section. 1. A cross section of a wing; the profile of the cross section or the area defined by the profile. See AIRFOIL SECTION and note. 2. A WING PANEL.

wing skid. A skid near a wing tip to keep the wing from scraping the ground. Used esp. on early airplanes.

wing span. The span of a wing, measured in a straight-line distance between tips or outermost extremities. See SPAN, sense 2.

This term is always applied to the entire wing; it is not applied to a half wing on one side of the fuselage or body.

wing-stub, noun. A STUB WING (in sense 2).

wing tank. A tank in or on a wing; esp. a fuel tank built into, and lying within, a wing.

wing tip. Also, less often, *wingtip*, *noun*. The outermost extremity or end portion of a wing. See *TIP*.

wing-tip aileron. An aileron, usually a floating aileron, located at the tip of a wing.

wing-tip bow. A curved member at the tip of certain wing structures, forming a round tip. Also called simply a "wing bow."

wing-tip float. Same as *OUTBOARD STABILIZING FLOAT*.

wing-tip rake. The inclination to the plane of symmetry of an airplane of a wing tip substantially straight in planform but not parallel to the plane of symmetry; the amount of this inclination, i. e., the *ANGLE OF RAKE*.

wing-tip tank. A streamlined fuel tank mounted externally at the outermost end of a wing. Often called simply a "tip tank."

wing-tip vortex. A tip vortex of a wing. See *TIP VORTEX*.

wing walking. The action of walking along a wing of an airplane in flight and sometimes also performing stunts on the wing. See *WALK*, sense 2.

wobble plate. A *SWASH PLATE*.

wobble pump. Specif., an auxiliary fuel pump operated by moving its hand lever back and forth.

wrinkle, verb intr. Of a sheet, plate, column, etc.: To become distorted with ridges or corrugations. Cf. *BUCKLE*.

—*wrinkling, noun.*

Wrinkling is a distortion of small amplitude, usually localized, often accompanying, and preliminary to, buckling or bending. Wrinkling is sometimes regarded as small-scale buckling.

W wing. A wing whose inboard sections are swept back and whose outboard sections are swept forward. Cf. *M WING*.

X

X-axis, noun. A designation for the longitudinal axis in a coordinate system of axes. See *AXIS*, sense 2 and note.

X-engine, noun. An internal-combustion

reciprocating engine having its cylinders so disposed about the crankshaft that they form, in an end view of the engine, the letter "X".

Y

yaw, noun. 1. The act of yawing; the rotational or oscillatory movement of an aircraft, rocket, or the like about a vertical axis. 2. The amount of this movement, i. e., the *ANGLE OF YAW*.

yaw, verb. 1. *tr.* To cause to rotate about a vertical axis. 2. *intr.* To rotate or oscillate about a vertical axis.

—*yawing, noun.*

yaw angle. Same as *ANGLE OF YAW*.

yaw axis. A vertical axis through an aircraft, missile, or similar body, about which the body yaws. It may be a body, wind, or stability axis. Also called a "yawing axis." See *AXIS*, sense 2 and note.

yawhead, noun. A device projected into a field of flow to detect any change in direction of the flow in a horizontal or lateral plane.

yawing axis. Same as *YAW AXIS*.

yawing moment. A moment that tends to rotate an aircraft, an airfoil, a rocket, etc. about a vertical axis. This moment is considered positive when it tends to retard the starboard side.

yawmeter, noun. An instrument that measures angles of yaw; a *YAWHEAD*.

Y-axis, noun. A designation for the lateral axis in a coordinate system of axes. See *AXIS*, sense 2 and note.

Y-engine, noun. An internal-combustion reciprocating engine with its cylinders so disposed about the crankshaft that they form, in an end view of the engine, the letter "Y."

yield load. The maximum load that a structure can withstand and still return to its original condition when the load is removed.

Z

zap flap. Any of a number of flaps designed by Edward F. Zap or Zaparka (now deceased); specif., a type of flap whose hinge axis moves rearward as the flap is deflected, the trailing edge moving in a plane perpendicular to the wing chord. Cf. *ALFARO FLAP*.

z-axis, noun. A designation for the vertical axis in a coordinate system of axes. See *AXIS*, sense 2 and note.

zenith distance. The angular distance of a celestial body from the zenith, measured through 90° along a vertical circle passing through the body, and equal to 90° minus the altitude of the body.

The zenith distance is sometimes expressed in nautical miles between the observer and the subpoint of the celestial body. When zenith distance is expressed in degrees, it is also called the "co-altitude."

Zeppelin, noun. Any rigid airship designed by, or of a type designed by, Ferdinand von Zeppelin (1838-1917), German aeronaut and engineer.

zero angle of attack. The position of an airfoil, fuselage, or other body when no angle of attack exists between two specified or understood reference lines. See *ANGLE OF ATTACK*, sense 1, and cf. *ZERO-LIFT ANGLE OF ATTACK*.

zero camber. No camber; also, no mean camber. See *MEAN CAMBER* and note.

zero-lift angle. Same as *ZERO-LIFT ANGLE OF ATTACK*.

zero-lift angle of attack. The geometric angle of attack at which no lift is created. Often called the "angle of

zero lift" or the "zero-lift angle." Cf. *ZERO ANGLE OF ATTACK*.

zero-lift chord. A chord taken through the trailing edge of an airfoil in the direction of the relative wind when the airfoil is at a zero-lift angle of attack.

Zero Reader. [A trade name.] A navigation instrument that combines attitude, altitude, heading, directional, and radio-navigational information to display on a single instrument face indications enabling a pilot to follow a chosen flight path.

zero-thrust pitch. The distance a propeller moves forward in one revolution provided it is delivering no thrust. Also called "dynamic pitch," "effective pitch" (which see, sense 2), "experimental mean pitch," "mean effective pitch," or "mean experimental pitch."

zero-zero, adj. Characterized by conditions such that there is no effective visibility in either a horizontal or a vertical direction, as in *zero-zero* weather.

Z marker. A location marker used at some radio-range stations to radiate a pattern above the station, thus aiding in determination of position above the station. Also sometimes used as an outer or middle marker in an instrument landing system. See *LOCATION MARKER*.

zoom, noun. A brief, steep climb in or of an airplane, the airplane's momentum being expended in the climb.

zoom, verb. 1. *intr.* Of an airplane or persons within: To make a zoom. 2. *tr.* To put into a zoom.

Bibliography

The following lists only those publications and other documents from which citations were extracted for the Dictionary. While most of these works were used for reference sources as well, the list does not include works used for reference only, which number in the hundreds and which date from the eighteenth century to the present. Most of these works are technical; some few more general, or popular, works were included, however, so as to obtain a fair sampling of the aeronautical language.

NOTE: This *Bibliography* is broken down into books, Government works, periodicals, and miscellaneous works. Works of anonymous authorship are entered alphabetically by title.

Books

- Aircraft Template Development. Revised ed., Aero Publishers (Glendale, Calif.), c. 1942.
- Anderson, Newton H.: Aircraft Layout and Detail Design. Second ed., McGraw-Hill Book Co., Inc., 1946.
- Andrews, John Paul: Gliding and Soaring. First ed., Robert M. McBride & Co. (New York), c. 1944.
- Armstrong, Harry G.: Principles and Practice of Aviation Medicine. The Williams and Wilkins Co., 1939.
- Baker, Morris B.: Airline Traffic and Operations. McGraw-Hill Book Co., Inc., 1947.
- Barringer, Lewin B.: Flight Without Power. Pitman Publishing Corp., c. 1940.
- Bauer, Hubert A.: Globes, Maps, and Skyways. The Macmillan Co., 1942.
- Beaumont, R. A.: Metallurgy for Aircraft Engineers, Inspectors, and Engineering Students. Sir Isaac Pitman & Sons, Ltd., 1946.
- Blackburn, Elbert F.: Basic Air Navigation. First ed., McGraw-Hill Book Co., Inc., 1944.
- Blackburn, John F., ed.: Components Handbook. First ed., McGraw-Hill Book Co., Inc., 1949.
- Blakemore, Thomas L., and Pagon, W. Watters: Pressure Airships. The Ronald Press Co., c. 1927.
- Bleviss, Zegmund O.: Interference Effects in Supersonic Flow. Thesis, California Institute of Technology, 1951.
- Bollinger, Lynn L., and Tully, Arthur H., Jr.: Personal Aircraft Business at Airports. Howard University Division of Research, Graduate School of Business Administration, 1948.
- Bond, Donald S.: Radio Direction Finders. First ed., McGraw-Hill Book Co., Inc., 1944.
- Bonney, E. Arthur.: Engineering Supersonic Aerodynamics. First ed., McGraw-Hill Book Co., Inc., 1950.
- Bridgman, Leonard, ed.: Jane's All the World's Aircraft—1943-44. The Macmillan Co., 1945.

- Bridgman, Leonard, ed.: Jane's All the World's Aircraft—1952-53. McGraw-Hill Book Co., Inc., n. d.
- Bridgman, Leonard, ed.: Jane's All the World's Aircraft—1954-55. McGraw-Hill Book Co., Inc., n. d.
- Brimm, D. J., Jr.: Air Acrobatics Are Easy. First ed., McGraw-Hill Book Co., 1943.
- Burgess, Charles P.: Airship Design. The Ronald Press Co., c. 1927.
- Burgess, Eric: Rocket Propulsion. Second ed., Chapman & Hall, Ltd., 1954.
- Cayley, Sir George: Note-Book—(ca. 1799-1826). The Newcomen Society (Cambridge, England), 1933.
- Chandler, Charles de Forest, and Diehl, Walter S.: Balloon and Airship Gases. The Ronald Press Co., c. 1926.
- Chapel, Charles Edward: Jet Aircraft Simplified. Aero Publishers, Inc. (Los Angeles), 1954.
- Chatfield, C. H., Taylor, C. Fayette, and Ober, Shatswell: The Airplane and Its Engine. McGraw-Hill Book Co., Inc., 1936.
- Cierva, Juan de la, and Rose, Don: Wings of Tomorrow. Brewer, Warren & Putnam (place not given), c. 1931.
- Clark, Virginius Evans: Elements of Aviation. The Ronald Press Co., c. 1928.
- Clevinger, Cloyd P.: Modern Flight. Grosset & Dunlap, c. 1941.
- Coler, Myron A.: Aircraft Engine and Metal Finishes. Pitman Publishing Corp., c. 1942.
- Columbia University Teachers College: Science of Pre-Flight Aeronautics. Revised ed., The Macmillan Co., 1944.
- Cooke, David C., and Caidin, Martin: Jets, Rockets and Guided Missiles. First ed., The McBride Co., c. 1951.
- Coulthard, W. H.: Aircraft Instrument Design. Pitman Publishing Corp., 1952.
- Crocco, Luigi, and Cheng, Sin-I: Theory of Combustion Instability in Liquid Propellant Rocket Motors. Butterworths Scientific Publications (Belfast), 1956.
- Davy, M. J. B.: Handbook of the Collections Illustrating Aeronautics—I—Heavier-than-Air Aircraft. His Majesty's Stationery Office, 1935.
- Davy, M. J. B.: Handbook of the Collections Illustrating Aeronautics—II—Lighter-than-Air Craft. His Majesty's Stationery Office, 1934.
- Dead Reckoning and Lines of Position. Part Three of Air Navigation, McGraw-Hill Book Co., Inc., 1943. Published by authority of and under the supervision of Training Division, Bureau of Aeronautics, U. S. Navy.
- Den Hartog, J. P.: Mechanical Vibrations. Second ed., McGraw-Hill Book Co., Inc., 1940.
- Design Techniques for Interference-Free Operation of Airborne Electronic Equipment. Frederick Research Corp. (Bethesda, Md.), 1952. (Reprinted by permission of Electronic Components Laboratory, Wright Air Development Center.)
- Diehl, Walter S.: Engineering Aerodynamics. The Ronald Press Co., c. 1928.
- Dommasch, Daniel O.: Elements of Propeller and Helicopter Aerodynamics. Pitman Publishing Corp., 1953.
- Dommasch, Daniel O., Sherby, Sydney S., and Connolly, Thomas F.: Airplane Aerodynamics. Pitman Publishing Corp., 1951.

- Drake, Col. Rollen H.: Aircraft Electrical Systems, Hydraulic Systems, and Instruments. The Macmillan Co., 1949.
- Drake, Col. Rollen H.: Aircraft Engine Maintenance and Service. The Macmillan Co., 1950.
- Drake, Col. Rollen H.: Aircraft Engines. The Macmillan Co., 1948.
- Drake, Col. Rollen H.: Aircraft Maintenance and Service. The Macmillan Co., 1949.
- Drake, Col. Rollen H.: Aircraft Woodwork. The Macmillan Co., 1946.
- Driggs, Ivan H., and Lancaster, Otis E.: Gas Turbines for Aircraft. The Ronald Press Co., c. 1955.
- Duffy, Thomas J.: Weight and Balance of Aircraft. Roosevelt Aviation School (Mineola, N. Y.), c. 1947.
- Durand, William Frederick, ed.: Aerodynamic Theory. Vol. I. Julius Springer (Berlin), 1934.
- Durand, William Frederick, ed.: Aerodynamic Theory. Vol. II. Julius Springer (Berlin), 1935.
- Durand, William Frederick, ed.: Aerodynamic Theory. Vol. III. Julius Springer (Berlin), 1935.
- Durand, William Frederick, ed.: Aerodynamic Theory. Vol. VI. Julius Springer (Berlin), 1936.
- Durham, Franklin P.: Aircraft Jet Powerplants. Prentice-Hall, Inc., c. 1951.
- Dutton, Commander Benjamin: Navigation and Nautical Astronomy. Tenth ed., United States Naval Institute (Annapolis), 1951.
- Dwinnell, James H.: Principles of Aerodynamics. First ed., McGraw-Hill Book Co., Inc., 1949.
- Eames, James P.: Elementary Airplane Structural Analysis by Graphic Methods. Aviation Press (San Francisco), c. 1938.
- Ferri, Antonio: Elements of Aerodynamics of Supersonic Flows. The Macmillan Co., 1949.
- Finch, Volney C.: Jet Propulsion—Turboprops. The National Press (Milbrae, Calif.), c. 1950.
- Fink, Donald G.: Radar Engineering. First ed., McGraw-Hill Book Co., Inc., 1947.
- Fitzpatrick, Frederick L., and Stiles, Karl A.: The Biology of Flight. The Macmillan Co., 1942.
- Fogg, Robert S., Strohmeier, William D., and Brimm, Daniel J., Jr.: Seaplane Flying and Operations. Pitman Publishing Corp., c. 1949.
- Fowler, Harlan D.: Fowler Flaps for Airplanes. Pacific Press, Inc. (Los Angeles), c. 1948.
- Frass, Arthur P.: Aircraft Power Plants. First ed., McGraw-Hill Book Co., Inc., 1943.
- Freberg, C. R., and Kemler, E. N.: Aircraft Vibration and Flutter. John Wiley & Sons, Inc., c. 1944.
- Frederick, John H.: Airport Management. Richard D. Irwin, Inc. (Chicago), 1949.
- Frederick, John H.: Commercial Air Transportation. Richard D. Irwin, Inc. (Chicago), 1955.
- Gatland, Kenneth W.: Development of the Guided Missile. Second ed., Iliffe & Sons, Ltd. (London), 1954.
- Gessow, Alfred, and Myers, Garry C., Jr.: Aerodynamics of the Helicopter. The Macmillan Co., c. 1952.
- Gilbert, Glen A.: Air Traffic Control. Ziff-Davis Publishing Co., c. 1945.

- Glasstone, Samuel: Sourcebook on Atomic Energy. D. Van Nostrand Co., Inc., c. 1950.
- Goddard, Robert H.: Rocket Development. Prentice-Hall, Inc., 1948.
- Godsey, F. W., Jr., and Young, Lloyd A.: Gas Turbines for Aircraft. First ed., McGraw-Hill Book Co., Inc., 1949.
- Graham, Lloyd: Rip Cord. Foster & Stewart Publishing Co. (Buffalo, N. Y.), c. 1936.
- Gray, George W.: Frontiers of Flight. Alfred A. Knopf, 1948.
- Grey, Charles G.: The History of Combat Airplanes. Norwich University, 1941.
- Haefner, Ralph, project director: Teaching Aeronautics in High Schools. McGraw-Hill Book Co., Inc., c. 1947.
- Halpine, Charles Greham: A Pilot's Meteorology. Second ed., D. Van Nostrand Co., Inc., 1953.
- Hamlin, Fred, Clawson, Arthur, Thayer, Eleanor, and McLarren, Robert, eds.: The Aircraft Year Book for 1952. Lincoln Press, Inc. (Washington), c. 1953.
- Hansen, Max, et al.: General Metallurgy. Vol. 31 of The American Fiat Review of German Science, 1939-1946. The M. H. Davidson Co. (New Haven, Conn.), 1950.
- Henney, Keith: Principles of Radio. Fifth ed., John Wiley & Sons, Inc., 1945.
- Hilton, W. F.: High-Speed Aerodynamics. First ed., Longmans, Green & Co., 1951.
- Hodge, James: Cycles and Performance Estimation. Butterworths Scientific Publications (London), 1955.
- Hodgson, J. E.: The History of Aeronautics in Great Britain. Oxford University Press, 1924.
- Hoerner, Sigward F.: Aerodynamic Drag. Published by the Author (Midland Park, N. J.), 1951.
- Holland, Maurice, and Smith, Thomas M.: Architects of Aviation. Duell, Sloan and Pearce, c. 1951.
- Hottel, H. C., Williams G. C., and Satterfield, C. N.: Thermodynamic Charts for Combustion Processes. Part One. Text. John Wiley & Sons, Inc., 1949.
- Howarth, L., ed.: Modern Developments in Fluid Dynamics. 2 vols. Clarendon Press (Oxford), 1953.
- Irvin, George Ellis: Aircraft Instruments. Second ed., McGraw-Hill Book Co., Inc., 1944.
- Johnston, S. Paul: Horizons Unlimited. First ed., Duell, Sloan and Pearce, c. 1941.
- Jordanoff, Assen: Your Wings. Funk & Wagnalls Co., 1937.
- Kármán, Theodore von: Aerodynamics—Selected Topics in the Light of Their Historical Development. Cornell University Press, 1954.
- Katz, Hyman H.: Aircraft Drafting. The Macmillan Co., c. 1946.
- Kaufmann, R. H., and Finison, H. J.: D-C Power Systems for Aircraft. John Wiley & Sons, Inc., 1952.
- Kelly, Fred C.: The Wright Brothers. First ed., Harcourt, Brace and Co., c. 1943.
- Kinert, Reed: American Racing Planes and Historic Air Races. Wilcox and Follett Co. (New York, etc.), c. 1952.
- Klein, Alexander: Airplane Stress Analysis. The Ronald Press Co., c. 1929.

- Kropf, Gene: *Airline Traffic Procedures*. First ed., McGraw-Hill Book Co., Inc., 1949.
- Kuethe, A. M., and Schetzer, J. D.: *Foundations of Aerodynamics*. John Wiley & Sons, Inc., c. 1950.
- Kukuski, John: *Theory and Technique of Soaring*. Sir Isaac Pitman & Sons, Ltd., 1952.
- Lamb, Sir Horace: *Hydrodynamics*. Sixth ed., Dover Publications, 1932.
- Lanchester, F. W.: *Aerodynamics*. A. Constable & Co., Ltd. (London), 1907.
- Langewiesche, Wolfgang: *Stick and Rudder*. McGraw-Hill Book Co., Inc., c. 1944.
- Langley, Marcus: *Seaplane Float & Hull Design*. Sir Isaac Pitman & Sons, Ltd., 1935.
- Langley, S. P.: *Experiments in Aerodynamics*. Second ed., no. 801, Smithsonian Contributions to Knowledge, The Smithsonian Institution, 1902.
- Langley, S. P.: *The Internal Work of the Wind*. No. 884, Smithsonian Contributions to Knowledge, The Smithsonian Institution, 1893.
- Latimer-Needham, C. H.: *Refueling in Flight*. Sir Isaac Pitman & Sons, Ltd., 1950.
- Lee, John G.: *Fighter Facts and Fallacies*. William Morrow and Co., 1942.
- Lent, Constantin Paul: *Rocket Research*. Pen-Ink Publishing Co. (New York), 1944.
- Lewellen, John: *Helicopters: How They Work*. Thomas Y. Crowell Co., c. 1954.
- Lewis, Bernard, and Elbe, Guenther von: *Combustion, Flames and Explosions of Gases*. Academic Press, Inc. (New York), 1951.
- Lewitt, E. H.: *The Rigid Airship*. Sir Isaac Pitman & Sons, Ltd., 1925.
- Ley, Willy: *Rockets, Missiles, and Space Travel*. The Viking Press, 1951.
- Liepmann, Hans Wolfgang, and Puckett, Allen E.: *Introduction to Aerodynamics of a Compressible Fluid*. John Wiley & Sons, Inc., c. 1947.
- Lindbergh, Charles A.: *The Spirit of St. Louis*. Charles Scribner's Sons, c. 1953.
- Lindholm, Richard W.: *Public Finance of Air Transportation*. Ohio State University, n. d.
- Liptrot, Capt. R. N., and Woods, J. D.: *Rotorcraft*. Butterworths Scientific Publications (London), 1955.
- Liston, Joseph: *Aircraft Engine Design*. First ed., McGraw-Hill Book Co., Inc., 1942.
- Lougheed, Victor: *Vehicles of the Air*. Second ed., The Reilly and Britton Co. (Chicago), c. 1910.
- Ludington, Charles Townsend: *Smoke Streams*. Coward-McCann, Inc., 1943.
- Lundgren, William R.: *Across the High Frontier*. William Morrow & Co., Inc., 1955.
- Lytel, Allan: *UHF Practices and Principles*. Second ed., John F. Rider Publisher, Inc. (New York), c. 1953.
- Malkin, Richard: *Boxcars in the Sky*. First ed., Import Publications, Inc. (New York), c. 1951.
- Mangurian, G. N., and Johnston, Norman M., eds.: *Aircraft Structural Analysis*. Prentice-Hall, Inc., 1947.

- Manly, G. B.: *Aircraft Powerplant Manual*. Revised ed., Frederick J. Drake & Co. (Chicago), c. 1943.
- Marcuvitz, N., ed.: *Waveguide Handbook*. First ed., McGraw-Hill Book Co., Inc., 1951.
- Mattingly, Charles: *American Air Navigator*. Consolidated Vultee Aircraft Corp. (San Diego), c. 1944.
- McFarland, Melvin W., ed.: *The Papers of Wilbur and Orville Wright*. 2 vols. McGraw-Hill Book Co., Inc., c. 1953.
- McFarland, Ross A.: *Human Factors in Air Transport Design*. First ed., McGraw-Hill Book Co., Inc., 1946.
- McIntosh, Colin Hugh: *Long-Range Flight*. First ed., McGraw-Hill Book Co., Inc., 1944.
- McShane, Edward J., Kelley, John L., and Reno, Franklin V.: *Exterior Ballistics*. University of Denver Press, c. 1953.
- Meacock, F. T.: *The Elements of Aircraft Propeller Design*. E. & F. N. Spon, Ltd. (London), 1947.
- Merrill, Capt. Grayson, ed.: *Principles of Guided Missile Design*. Unpublished mimeographed copy, n. d. (Now published by D. Van Nostrand Co., Inc.)
- Millikan, Clark B.: *Aerodynamics of the Airplane*. John Wiley & Sons, Inc., c. 1941.
- Millman, Jacob, and Seely, Samuel: *Electronics*. Second ed., McGraw-Hill Book Co., Inc., 1951.
- Mingos, Howard, ed.: *The Aircraft Year Book for 1945*. Lancia Publishers, Inc. (New York), c. 1945.
- Mises, Richard von: *Theory of Flight*. First ed., McGraw-Hill Book Co., Inc., 1945.
- Molloy, E., ed.: *Magnetos*. Chemical Publishing Co., Inc. (Brooklyn), 1941.
- Morris, Lloyd, and Smith, Kendall: *Ceiling Unlimited*. The Macmillan Co., 1953.
- Moss, Dr. Sanford A.: *Superchargers for Aviation*. National Aeronautics Council, Inc. (New York), 1942.
- Mumma, J. V.: *Parachutes*. The Campbell Co. (San Diego), c. 1930.
- Munk, Max M.: *Fundamentals of Fluid Dynamics for Aircraft Designers*. The Ronald Press Co., c. 1929.
- Munk, Max M.: *The Principles of Aerodynamics*. Published by the Author (Washington), c. 1933.
- Nautical Astronomy and Celestial Navigation*. Part Seven of Air Navigation, McGraw-Hill Book Co., 1944. Published by authority of and under the supervision of Training Division, Bureau of Aeronautics, U. S. Navy.
- Nelson, William: *Airplane Lofting*. First ed., McGraw-Hill Book Co., Inc., 1941.
- Neville, Leslie E., and Silsbee, Nathaniel F.: *Jet Propulsion Progress*. First ed., McGraw-Hill Book Co., Inc., 1948.
- Newell, Homer E., Jr.: *High Altitude Rocket Research*. Academic Press, Inc. (New York), 1953.
- Nikolsky, Alexander A.: *Helicopter Analysis*. John Wiley & Sons, Inc., c. 1951.
- Nikolsky, Alexander A.: *Notes on Helicopter Design Theory*. Princeton University Press, 1944.

- Niles, Alfred S., and Newell, Joseph S.: *Airplane Structures*. Vol. I. Fourth ed., John Wiley & Sons, Inc., 1954.
- Niles, Alfred S., and Newell, Joseph S.: *Airplane Structures*. Vol. II. Third ed., John Wiley & Sons, Inc., c. 1943.
- Norman, C. A., and Zimmerman, R. H.: *Introduction to Gas-Turbine and Jet-Propulsion Design*. Harper & Brothers, c. 1948.
- Northrop Aeronautical Institute: *Aircraft Basic Science*. Revised ed., McGraw-Hill Book Co., Inc., 1953.
- Northrop Aeronautical Institute: *Aircraft Maintenance and Repair*. Revised ed., McGraw-Hill Book Co., Inc., 1955.
- Northrop Aeronautical Institute: *Aircraft Power Plants*. Revised ed., McGraw-Hill Book Co., Inc., 1955.
- Norwood, A. G.: *Private Pilot's Handbook*. Second ed., Pitman Publishing Corp., c. 1949.
- Nye, Willis L.: *Practical Aeronautical Engineering*. Aviation Press (San Francisco), c. 1938.
- Pankhurst, R. C., and Holder, D. W.: *Wind-Tunnel Technique*. Sir Isaac Pitman & Sons, Ltd., 1952.
- Pendray, G. Edward: *The Coming Age of Rocket Power*. Harper & Brothers, c. 1945.
- Perkins, Courtland D., and Hage, Robert E.: *Airplane Performance—Stability and Control*. John Wiley & Sons, Inc., c. 1949.
- Perrie, D. W.: *Cloud Physics*. John Wiley & Sons, Inc., 1950.
- Place, Marian Templeton (Dale White, pseud.), and Florek, Larry: *Tall Timber Pilots*. The Viking Press, 1953.
- Pollard, Capt. A. O.: *The Royal Air Force*. Hutchinson & Co., Ltd. (London), n. d.
- Pollard, Ernest, and Davidson, William L.: *Applied Nuclear Physics*. John Wiley & Sons, Inc., c. 1942.
- Pope, Alan: *Aerodynamics of Supersonic Flight*. Pitman Publishing Corp., 1950.
- Pope, Alan: *Basic Wing and Airfoil Theory*. First ed., McGraw-Hill Book Co., Inc., 1951.
- Pope, Alan: *Wind-Tunnel Testing*. Second ed., John Wiley & Sons, Inc., c. 1954.
- Principles of Flying*. McGraw-Hill Book Co., Inc., 1943. Published by authority of and under the supervision of Training Division, Bureau of Aeronautics, U. S. Navy.
- Private Pilot Training*. First ed., Aviation Sales Corp. (Los Angeles), c. 1948.
- Renner, George T., and Bauer, Hubert A.: *The Air We Live In*. The Macmillan Co., 1942.
- Richardson, E. G.: *Dynamics of Real Fluids*. Edward Arnold & Co. (London), 1950.
- Roberts, Arthur, ed.: *Radar Beacons*. First ed., McGraw-Hill Book Co., Inc., 1947.
- Roberts, Henry W.: *Aviation Radio*. William Morrow & Co., 1945.
- Rosendahl, Commander C. E.: *What About the Airship?* Charles Scribner's Sons, 1938.
- Ross, Frank, Jr.: *Guided Missiles: Rockets & Torpedoes*. Lothrop, Lee & Shepard Co., Inc. (New York), c. 1951.

- Rosser, J. Barkley, Newton, Robert R., and Gross, George L.: *Mathematical Theory of Rocket Flight*. First ed., McGraw-Hill Book Co., Inc., 1947.
- Russell, George E.: *Hydraulics*. Fifth ed., Henry Holt & Co., c. 1942.
- Ryan, Lloyd F.: *Experiments on Aerodynamic Cooling*. Verlag Leeman (Zurich), 1951. Thesis, Federal Institute of Technology, Zurich.
- Sanders, C. J., and Rawson, A. H.: *The Book of the C.19 Autogiro*. Sir Isaac Pitman & Sons, Ltd., 1931.
- Schlaifer, Robert, and Heron, S. D.: *Development of Aircraft Engines and Fuels*. Harvard University, Graduate School of Business Administration, Research Division, 1950.
- Sears, William R.: *The Airplane and Its Components*. John Wiley & Sons, Inc., 1942.
- Sears, W. R., ed.: *High Speed Aerodynamics and Jet Propulsion*. Vol. VI of *General Theory of High Speed Aerodynamics*. Princeton University Press, 1954.
- Shanley, F. R.: *Weight-Strength Analysis of Aircraft Structures*. First ed., McGraw-Hill Book Co., Inc., 1952.
- Shapiro, Ascher H.: *The Dynamics and Thermodynamics of Compressible Fluid Flow*. 2 vols. The Ronald Press Co., c. 1953–c. 1954.
- Sherwood, A. Wiley: *Aerodynamics*. First ed., McGraw-Hill Book Co., Inc., 1946.
- Shields, Bert A.: *Air Pilot Training*. Fourth ed., McGraw-Hill Book Co., Inc., 1952.
- Shields, Bert A.: *Learning to Fly*. Pitman Publishing Corp., 1949.
- Silver, Samuel, ed.: *Microwave Antenna Theory and Design*. First ed., McGraw-Hill Book Co., Inc., 1949.
- Smith, Edward S. C., Fox, A. H., Sawyer, R. Tom, and Austin, H. R.: *Applied Atomic Power*. Prentice-Hall, Inc., 1946.
- Smith, G. Geoffrey: *Gas Turbines and Jet Propulsion for Aircraft*. Fourth ed., Aircraft Books, Inc. (New York), c. 1946.
- Smith, H. T. U.: *Aerial Photographs and Their Applications*. D. Appleton-Century Co., c. 1943.
- Smith, R. A.: *Radio Aids to Navigation*. The Macmillan Co., 1948.
- Society for Experimental Stress Analysis: *Experimental Stress Analysis*. Vol. I, no. I. Addison-Wesley Press, Inc. (Cambridge, Mass.), c. 1943.
- Society for Experimental Stress Analysis: *Experimental Stress Analysis*. Vol. I, no. II. Addison-Wesley Press, Inc. (Cambridge, Mass.), c. 1944.
- Stalker, Edward Archibald: *Principles of Flight*. The Ronald Press Co., c. 1931.
- Standing Committee on Combustion Symposia: *Fourth Symposium on Combustion and Flame and Explosion Phenomena*. The Williams & Wilkins Co., 1953.
- Stephenson, Richard: *Introduction to Nuclear Engineering*. McGraw-Hill Book Co., Inc., 1954.
- Sutton, George P.: *Rocket Propulsion Elements*. John Wiley & Sons, Inc., 1949.
- Sutton, O. G.: *Micrometeorology*. McGraw-Hill Book Co., Inc., 1953.
- Taylor, George F.: *Aeronautical Meteorology*. Revised and enlarged ed., Pitman Publishing Corp., c. 1941.

- Theodorsen, Theodore: Theory of Propellers. First ed., McGraw-Hill Book Co., Inc., 1948.
- Thompson, James G.: Aviation Service and Maintenance. Aviation Press (San Francisco), c. 1937.
- Thorner, Robert H.: Aircraft Carburetion. John Wiley & Sons, Inc., c. 1946.
- Titterton, George F.: Aircraft Materials and Processes. Fourth ed., Pitman Publishing Corp., c. 1951.
- United States Atomic Energy Commission: Research Reactors. McGraw-Hill Book Co., Inc., 1955.
- Upson, Ralph H., and Chandler, Charles deForest: Free and Captive Balloons. The Ronald Press Co., c. 1926.
- Vale, John W., Jr.: The Aviation Mechanic's Aircraft Manual. First ed., McGraw-Hill Book Co., Inc., 1949.
- Vale, John W., Jr.: The Aviation Mechanic's Engine Manual. First ed., McGraw-Hill Book Co., Inc., 1946.
- Varney, Alex: The Psychology of Flight. D. Van Nostrand Co., Inc., c. 1950.
- Vivian, E. Charles, and Marsh, Lieut.-Col. W. Lockwood: A History of Aeronautics. W. Collins & Co., Ltd., c. 1921.
- Warner, Edward P.: Aerostatics. The Ronald Press Co., c. 1926.
- Warner, Edward P.: Airplane Design—Aerodynamics. First ed., McGraw-Hill Book Co., Inc., 1927.
- Warner, Edward P.: Airplane Design—Performance. Second ed., McGraw-Hill Book Co., Inc., 1936.
- Weems, P. V. H.: Air Navigation. Third ed., McGraw-Hill Book Co., Inc., 1943.
- Weick, Fred E.: Aircraft Propeller Design. First ed., McGraw-Hill Book Co., Inc., 1930.
- Wenham, F. H.: Aerial Locomotion. The Aeronautical Society of Great Britain (London), 1910. (First published 1866.)
- Westinghouse Electric Corporation: Alternating-Current Electrical Systems for Aircraft. Westinghouse Electric Corp., Aircraft Dept., 1951.
- White, Clayton S., and Benson, Otis O., Jr., eds.: Physics and Medicine of the Upper Atmosphere. University of New Mexico Press, 1952.
- White, Dale (pseud.): See Place, Marian Templeton.
- Wilkinson, Paul H.: Aircraft Engines of the World—1953. Paul H. Wilkinson (New York), c. 1953.
- Wood, Karl D.: Airplane Design. Eighth ed., published by the Author (Boulder, Colo.), c. 1947.
- Wood, Karl D.: Technical Aerodynamics. First ed., McGraw-Hill Book Co., Inc., 1935.
- Wood, Karl D.: Technical Aerodynamics. Second ed., McGraw-Hill Book Co., Inc., 1947.
- Wood, Karl D., and Wheatley, William B.: Elementary Aerodynamics. Published by the Authors (Ithaca, N. Y.), 1935.
- Wright, Orville, and Wright, Wilbur: See McFarland, Melvin W.
- Young, Raymond A.: Helicopter Engineering. The Ronald Press Co., c. 1949.
- Zweng, Charles A.: Flight Engineers Manual. Third ed., Pan American Navigation Service (North Hollywood, Calif.), c. 1954.

- Zweng, Charles A.: Flying the Omnirange. Third ed., Pan American Navigation Service (North Hollywood, Calif.); Weems System of Navigation (Annapolis, Md.), 1955.
- Zweng, Charles A.: Helicopter Rating. First ed., Pan American Navigation Service (North Hollywood, Calif.), c. 1954.
- Zweng, Charles A., and Zweng, Allen C.: Radio and Instrument Flying. Thirteenth ed., Pan American Navigation Service (North Hollywood, Calif.), c. 1954.

United States Government Agencies and Departments—Reports, Manuals, etc.

- Atomic Energy Commission: See United States Atomic Energy Commission, under "Books."
- Civil Aeronautics Administration:
- Aircraft Powerplant Handbook. Government Printing Office, 1949. (CAATM 107.)
 - Airport Planning. 1952.
 - ANC Procedures for the Control of Air Traffic. 1952.
 - Basic Instrument Flight. Office of Aviation Training, 1946.
 - Basic Instrument Flight—Instructor's Syllabus. U. S. Department of Commerce, n. d.
 - Distance Measuring Equipment and Offset Course Computer. Third ed., Government Printing Office, 1952.
 - Flight Instruction Manual. 1951. (CAATM 100.)
 - Gassmann, J. J.: Determination of Ignition Characteristics of Hydraulic Fluids. Part I: Simulated Flight and Crash Conditions. Technical Development and Evaluation Center (Indianapolis), 1951. (Technical Development Report no. 64.)
 - Gassmann, J. J.: Determination of Ignition Characteristics of Hydraulic Fluids. Part II: Flammability Reference Scale. Technical Development and Evaluation Center (Indianapolis), 1951. (Technical Development Report no. 142.)
 - Instrument Landing System. Bull. no. 1, third ed., Government Printing Office, 1952.
 - Location Markers and Homing Facilities. Bull. no. 2, second ed., Government Printing Office, 1951.
 - Operation of the Air Traffic Control System. 1953.
 - Pilot's Weather Handbook. Government Printing Office, 1955. (CAATM 104.)
 - Progress Report—Aircraft Fire Prevention Program. Technical Development and Evaluation Center (Indianapolis), Sept. 1951. (Mimeographed.)
 - Visual-Aural Ranges and Omniranges. Second ed., Government Printing Office, 1953.
- Department of the Air Force:
- Aerial Target—Techniques and Procedures. 1954. (AFM 51-8.)
 - Aircraft Engineering for Pilots. 1955. (AFM 51-42.)
 - Air Navigation. Vol. 1. 1954. (AFM 51-40.)
 - Air Navigation. Vol. 2. 1955. (AFM 51-40.)

Department of the Air Force—Continued

Air Training Command:

- Aircraft and Engine Mechanic—Liaison. Scott Air Force Base, 1954. (ATRC Manual 52-10.)
 Radio Compass and Simple Navigation. Scott Air Force Base, 1953. (ATRC Manual 52-3.)
 Instrument Flying—Techniques and Procedures. 1953. (AFM 51-37.)
 Instrument Flying—Techniques and Procedures for Jet Aircraft. 1953. (AFM 51-45.)
 Physiology of Flight. 1953. (AFM 160-30.)
 Theory of Instrument Flying. 1954. (AFM 51-38.)
 Weather for Aircrew Trainees. 1951. (AFM 105-5.)

Department of the Army:

- Army Artillery School: An Introduction to Guided Missiles. The Artillery School, Antiaircraft and Guided Missiles Branch (Fort Bliss), 1950.

Department of the Navy:

- Airship Ground Handling Instructions. 1954. (NAVAER 01-1F-501.)
 All-Weather Flight Manual. 1950. (NAVAER 00-80T-37.)
 Bureau of Naval Personnel:
 Aerology. Vol. 1. Government Printing Office, 1951.
 Aerology. Vol. 2. Government Printing Office, 1945.
 Parachute Rigger. Vol. 1. 1949.
 Parachute Rigger. Vol. 2. 1951.
 Cruise Control for Pilots. 1952. (NAVAER 00-80T-44.)
 Grover, H. J., Gordon, S. A., and Jackson, L. R.: Fatigue of Metals and Structures. Government Printing Office, 1954. Prepared for Bureau of Aeronautics, Department of the Navy (NAVAER 00-25-534).
 Handbook Maintenance Instructions, Navy Models ZP2K and ZP3K Airships. 1954. (NAVAER 01-195PAA-502.)
 Helicopter Training Manual. 1952. (NAVAER 00-80T-41.)
 Jet Power in Naval Aircraft. 1949. (NAVAER 02-1-514.)
 Naval Air Technical Training Command:
 Aircraft Hydraulics. Government Printing Office, 1951.
 Aircraft Instruments. Government Printing Office, 1954.
 Naval Ordnance Laboratory: Symposium on Ordnance Aeroballistics (Silver Spring, Md.). 1950. (NOLR 1131.)
 Navy Airman's Manual. 1953. (NAVAER 00-80T-46.)
 Office of Naval Operations:
 Aerology for Naval Aviators. 1952. (NAVAER 00-80U-22.)
 Flight thru Instruments. 1945.
 Pilot's Handbook, Navy Models ZP2K and ZP3K Airships. 1953. (NAVAER 01-195PAA-501.)
 Safety and Survival Equipment for Naval Aviation. 1954. (NAVAER 00-80T-52.)
 High Speed Flight Information for Pilots. 1951. (NAVEXOS P-960.)
 The Techniques of Towing Aerial Targets. 1950. (NAVAER 00-80T-35.)

National Advisory Committee for Aeronautics:

NOTE: The bibliography of NACA material is so voluminous that it is given in the following manner in order to conserve space.

Selected NACA Reports, Research Memorandums, Technical Memorandums, Technical Notes, and Wartime Reports. 1922-1958.
 President's Airport Commission: The Airport and Its Neighbors. Government Printing Office, 1952.

Periodicals

NOTE: In order to conserve space, only the volume number and date are given, the issue number being omitted.

- Aero Digest. Vol. 56, Jan.-June, 1948; vol. 65, Oct.-Dec., 1952; vol. 68, Apr., July, Nov., 1954; vol. 70, Jan.-June, 1955; vol. 71, July-Dec., 1955; vol. 73, July, Aug., 1956.
 Aeronautical Engineering Review (now Aero/Space Engineering). Vol. 1, May, June, Aug.-Oct., 1942; vol. 12, Feb.-Oct., 1953; vol. 13, Jan., Mar., May, June, 1954; vol. 14, May, 1955; vol. 15, May, Oct., Nov., 1956; vol. 16, Jan., Mar.-Aug., Oct., 1957.
 Aeronautics. Vol. 31, Oct., 1954; vol. 32, Apr., 1955.
 The Aeroplane. Vol. LXXXIII, Oct. 3, 1952; vol. LXXXVIII, Apr. 15, 1955.
 Aero/Space Engineering (formerly Aeronautical Engineering Review). Vol. 17, Aug., 1958.
 Aircraft Engineering. Vol. 29, Nov., 1957.
 Air Facts. Vol. 17, Aug., 1954.
 Air Force. Vol. 26, Dec., 1943; vol. 33, Jan., Apr., 1950.
 American Aviation. Vol. 18, Oct. 11, 1954; vol. 19, July 18, Nov. 21, 1955; vol. 20, Oct. 22, 1956; vol. 21, Aug. 12, 1957.
 American Helicopter. Vol. XIII, Jan., Feb., 1949; vol. XV, June-Aug., 1949; vol. XVI, Sep., 1949; vol. XVIII, Mar., 1950; vol. XX, Sep., Oct., 1950; vol. XXI, Jan., 1951; vol. XXII, Mar., May, 1951; vol. XXIII, June, 1951; vol. XXV, Feb., 1952; vol. XXVI, Mar., 1952; vol. XXVII, July, Aug., 1952; vol. XXXV, July, Aug., 1954; vol. XXXVIII, Mar., 1955; vol. XXXXIV, Oct., 1956; vol. XXXXVI, May, 1957; vol. XXXXVII, June, July, 1957.
 American Rocket News. Vol. 1, Mar., Apr., 1957.
 Applied Hydraulics. Vol. 6, Sep., Nov., Dec., 1953.
 Astronautics. Vol. 2, Nov., 1957; vol. 3, May, 1958.
 Aviation Week. Vol. 62, Feb. 7, Mar. 28, 1955; vol. 63, Sep. 5-19, Oct. 24, Nov. 7, 21, Dec. 19, 1955; vol. 64, Jan. 23, June 25, 1956; vol. 65, Oct. 1, Nov. 12, 26, Dec. 17, 31, 1956; vol. 66, Jan. 28, Feb. 4, Apr. 22, May 6, 20, July 1, 1957; vol. 67, July 8-29, Aug. 12, Sep. 16, Oct. 7, 14, 28, Nov. 18, Dec. 9, 1957; vol. 68, Feb. 10, Apr. 14, 28, May 12, 26, 1958; vol. 69, Aug. 4, 1958.
 Combat Crew. Vol. IV, Jan., May, 1954; vol. V, July, Nov., 1954.
 De Havilland Gazette. Aug., 1955.
 Electrical Communication. Vol. 29, Mar., Sep., 1952.
 Federal Register. Vol. 20, Dec. 14, 1955.
 Flight. Vol. 41, Jan.-Mar., 1954; vol. 43, Apr., 1955; vol. 44, Sep., Nov., 1955; vol. 45, Sep., Oct., 1956.

- Flight (British). Vol. I, Feb. 20, Oct. 30, 1909.
 Flying. Vol. 56, Mar., June, 1955; vol. 57, Oct., 1955; vol. 58, Jan., 1956; vol. 62, Mar., Apr., 1958.
 Flying Safety. Vol. 10, May, June, Sep., Dec., 1954; vol. 11, Feb., 1955.
 General Electric Review. Vol. 56, July, 1953; vol. 57, Jan., Mar., May, Sep., Nov., 1954; vol. 58, Jan., May, 1955.
 ICAO Bulletin. Vol. XII, no. 1, 1957.
 Jet Propulsion. Vol. 24, Jan.-Feb., Sep.-Oct., Nov.-Dec., 1954; vol. 25, Aug.-Oct., 1955.
 The Journal of Aviation Medicine. Vol. 26, Feb., 1955.
 Journal of the Aeronautical Sciences. Vol. 19, Jan.-Dec., 1952; vol. 23, Aug., Oct., 1956.
 Journal of the American Helicopter Society. Vol. 1, Apr., July, 1956.
 Journal of the Royal Aeronautical Society. Vol. 59, Aug., 1955.
 Missile Engineering. Vol. 1, Dec., 1956.
 Missiles and Rockets. Vol. 1, Oct.-Dec., 1956; vol. 2, Jan., Mar.-June, Sep., 1957; vol. 3, Feb., 1958.
 Naval Aviation News, Jan., Feb., June, 1947; Jan., 1948; Nov., 1949; Mar., 1950; Feb., Apr., June, 1951; Jan., Sep., Nov., Dec., 1952; Jan., Feb., July, 1953; Mar., June-Oct., Dec., 1954.
 Nucleonics. Vol. 12, Oct., 1954.
 Pegasus. Vol. 24, Oct., Nov., 1955.
 Quarterly of Applied Mathematics. Vol. XII, Jan., 1955.
 Ryan Reporter. Vol. 16, Aug. 5, Oct. 7, 1955.
 SAE Journal. Vol. 62, Oct., 1954; vol. 63, Jan., Sep., 1955.
 Shell Aviation News. June-Aug., 1955.
 Shorts Quarterly Review. Vol. 2, nos. 7, 8, 1955.
 Skyways. Vol. 14, Jan.-Mar., Nov., 1955; vol. 16, Apr., 1957.
 Soaring. Vol. 18, Sep.-Oct., 1954.
 U. S. Air Services. Vol. 40, Aug., 1955.
 Western Aviation. Vol. 34, Oct., Dec., 1954; vol. 35, Jan., Mar., Apr., July-Dec., 1955; vol. 37, May-Sep., 1957.
 WMO Bulletin. Vol. 3, Oct., 1954; vol. 4, Jan., 1955; vol. 6, Oct., 1957.

NOTE: In addition to the above periodicals, certain popular periodicals, such as Time, Newsweek, etc., were also examined for citations of aeronautical language.

Miscellaneous Pamphlets and Papers

- American Airlines, Inc.: Welcome Aboard. 1956. (Informational booklet for airline passengers.)
 American Helicopter Society: First Convertible Aircraft Congress. Institute for the Aeronautical Sciences, 1949.
 American Society of Mechanical Engineers: Automatic Control Terminology. 1954. (ASME Standard 105.)
 C. A. S. I. Subcommittee of F. A. I.: Classification and Definitions of Rotating Wing and Vertical Take-Off Aircraft Adopted by C. A. S. I. of Federation Aeronautique Internationale in Paris, June, 1955.
 General Electric Company: Aircraft Electrical Symposium. c. 1954.
 Herman, Rudolf: Engine Inlet Air Diffuser Controls for Supersonic Aircraft. Society of Automotive Engineers 1956. (Paper presented at the SAE National Aeronautic Meeting, April, 1956.)
 Institute of the Aeronautical Sciences: Program and abstracts of papers presented at the twenty-fourth annual meeting. January, 1956.

- Kaufman, Lawrence, and Peress, Kenneth: A Review of Methods for Predicting Helicopter Longitudinal Response. Institute of the Aeronautical Sciences, Inc., 1955.
 Krueger, William G.: Lecture on Artificial Flight. (Given at the Academy of Natural Sciences, San Francisco, Aug. 7, 1876.)
 Loening, Grover: The Economics of Large Aircraft. Society of Automotive Engineers, 1956. (Paper presented at a meeting of the Philadelphia Section of the Society of Automotive Engineers, January, 1956.)
 Matthews, Joseph B., Jr.: Airborne Automatic Navigation. (Paper presented at the Eastern Regional Meeting of the Institute of Navigation, 1955.)
 Ministry of Supply, Aeronautical Research Council: Report of the Definitions Panel on the Definitions of the Thrust of a Jet Engine and of the Internal Drag of a Ducted Body. Her Majesty's Stationery Office, 1955.
 RTCA Special Committee 31: Air Traffic Control. Radio Technical Commission for Aeronautics, 1948. (Paper 27-48/DO-12.)
 U. S. Air Coordinating Committee: Commercial Possibilities of Lighter-than-air Aircraft. (Press release, May 22, 1947.)
 U. S. Department of Defense: Briefing of Press on Guided Missiles Background Information. Office of Public Information, 1955. (Press reception by Assistant Secretary of Defense Donald A. Quarles.)

○