

300

TM 9-1005-211-34

DEPARTMENT OF THE ARMY TECHNICAL MANUAL

DIRECT AND GENERAL SUPPORT
MAINTENANCE MANUAL
PISTOL, CALIBER .45,
AUTOMATIC, M1911A1



HEADQUARTERS, DEPARTMENT OF THE ARMY
22 JUNE 1964

Technical Manual

No. 9-1005-211-34



HEADQUARTERS,
DEPARTMENT OF THE ARMY
WASHINGTON, D.C., 20315 22 June 1964

PISTOL, CALIBER .45, AUTOMATIC, M1911A1

		Paragraphs	Pages
CHAPTER	1. INTRODUCTION		
Section	I. General	1-3	2
	II. Description and data	4,5	3
CHAPTER	2. PARTS, SPECIAL TOOLS, AND EQUIPMENT	6-10	7
CHAPTER	3. INSPECTIONS		
Section	I. General	11-13	12
	II. Inspection procedures	14-16	13-15
CHAPTER	4. GENERAL MAINTENANCE	17-23	18,19
CHAPTER	5. REPAIR		
Section	I. Cartridge magazine	24-28	21
	II. Barrel and slide group	29-33	22-28
	III. Receiver group	34-38	28-37
CHAPTER	6. FINAL INSPECTION	39,40	38
CHAPTER	7. PREPARATION AND SHIPPING INSTRUCTIONS	41-43	41
APPENDIX	REFERENCES		42
INDEX			44

*This manual supersedes TM 9-2951-1, 19 July 1957.

CHAPTER 1

INTRODUCTION

Section I. GENERAL

1. Scope

a. This manual is published for the information and guidance of personnel responsible for direct and general support maintenance of the caliber .45 automatic pistol M1911A1. It contains information on maintenance which is beyond the scope of tools, equipment, or supplies normally available to using organizations.

b. This manual contains a description of and procedures for disassembly, inspection, repair and assembly of the caliber .45 automatic pistol M1911A1. The appendix contains a list of current references, including supply manuals, technical manuals and other available publications applicable to the materiel. The maintenance allocation charts are contained in TM 9-1005-211-12P/2. TM 9-1005-211-35P contains a list of repair parts and special tools.

c. TM 9-1005-211-12P/2 contains a listing of operator and organizational maintenance repair parts and special tools.

d. Lubricating instructions for the materiel are contained in paragraph 23 of this manual.

e. The direct reporting of errors, omissions and recommendations for improving this equipment manual by the individual user, is authorized and encouraged. DA Form 2028 will be used for reporting these improvements. This form may be completed using pencil, pen or typewriter. DA Form 2028 will be completed by the individual using the manual and forwarded direct to:

Commanding General
Headquarters
U. S. Army Weapons Command
ATTN: AMSWE-SMM-P
Rock Island Arsenal
Rock Island, Illinois 61202

f. This manual differs from TM 9-2951-1 dated 19 July 1957 as follows:

- (1) Adds pertinent information on:

Barrel and slide group
Receiver group
Cartridge magazine
Troubleshooting
Trigger pull test
Trigger pull correction
Hand function test.

- (2) Revises information on:
Special tools and equipment
Improvised tools
Direct and general support maintenance.
- (3) Deletes specific maintenance instructions for caliber .45 automatic pistol M1911.

2. Direct and General Support Maintenance Allocation

The publication of instructions for complete disassembly is not to be construed as authority for the performance by direct and general support maintenance units of those functions which are restricted to depots and arsenals. In general, the prescribed maintenance responsibilities will be reflected in the maintenance allocation chart in TM 9-1005-211-12P/2. Supply of parts listed in the depot guide column of TM 9-1005-211-35P will be made to direct and general support maintenance only when the emergency nature of the maintenance to be performed has been certified by a responsible officer of the requisitioning organization.

3. Forms, Records, and Reports

a. *General.* Responsibility for the proper execution of forms, records, and reports rests upon the officers of all units maintaining this equipment. However, the value of accurate records must be fully appreciated by all persons responsible for their compilation, maintenance, and use. Records, reports and authorized forms are normally utilized to indicate the type,

quantity and condition of materiel to be inspected, repaired or used in repair. Properly executed forms convey authorization and serve as records for repair or replacement of materiel in the hands of troops.

b. Authorized Forms. The forms generally applicable to units maintaining this materiel are listed in the appendix. For a listing of these forms, refer to DA Pam 310-2. For instructions on use of these forms, refer to TM 38-750.

c. Field Reports of Accidents.

- (1) *Injury to personnel or damage to materiel.* The reports necessary to comply with requirements of the Army safety program are prescribed in detail in AR 385-40. These reports are required whenever accidents involving injury to personnel or damage to materiel occur.

- (2) *Ammunition.* Whenever an accident or malfunction involving the use of ammunition occurs, firing of the lot which malfunctions will immediately be discontinued. In addition to any applicable reports required in (1) above, details of the accident or malfunction will be reported as prescribed in AR 700-1300-8.

d. Report of Unsatisfactory Equipment or Materials. Any deficiencies detected in the equipment covered herein which occur under the circumstances indicated in AR 750-5 should be reported immediately in accordance with applicable instructions in cited regulations.

e. Equipment Improvement Recommendations. Deficiencies detected in the equipment or materials should be reported, using the Equipment Improvement Recommendation section of DA Form 2407.

Section II. DESCRIPTION AND DATA

4. Description

a. The caliber .45 automatic pistol, M1911A1 (figs. 1 and 2) is a recoil-operated, magazine-fed, self-loading hand weapon. It contains an inertia-type firing pin that makes it impossible for the firing pin to discharge or touch the primer, except on receiving the impact of the hammer. The action of the recoil spring forces the slide forward, feeding a live cartridge from the magazine into the chamber. The weapon is now ready to fire again.

b. The pistol is designed to fire caliber .45 cartridge ball ammunition and the magazine holds seven cartridges. The upper cartridge is stripped from the magazine and forced into the chamber by the forward motion of the slide. The pistol will fire once at each squeeze of the trigger and when the last cartridge, in the magazine, has been fired the slide remains open. The rate of fire is limited only by the ability of the operator to insert the magazine and to squeeze the trigger.

c. The M1911 pistols still available in

the field will be maintained using M1911A1 repair parts.

d. For convenience of maintenance and replacement of repair parts, the M1911A1 pistol is ~~divided~~ into groups and components as indicated in figure 3.

5. Tabulated Data

a. Weights.

Weight of pistol with
magazine (empty) 2.437 lb
Weight of loaded mag-
azine with 7 rounds
(approximate) 0.481 lb
Weight of empty
magazine 0.156 lb

b. Trigger Pull.

Pistols, new or repaired 5 to 6-1/2 lb

c. Barrels.

Diameter of bore 0.45 in.
Number of grooves 6
Length of barrel 5.03 in.
Length of rifling (min.) 4.118 in.

Rifling, L.H. one turn in 16 in.
Depth of grooves 0.003 in.
d. Pistol, General.
Length (overall) 8-5/8 in.
Cooling system air
Height of front sight above
axis of bore 0.5597 in.
Sight radius 6.481 in.

e. Ballistics.
Chamber pressure
(maximum) 17,000 psi
Muzzle velocity
(maximum) 830 fps
Maximum range 1500 meters
Maximum effective
range 50 meters



ORD F2020

Figure 1. Caliber .45 automatic pistol M1911A1 - right front view.

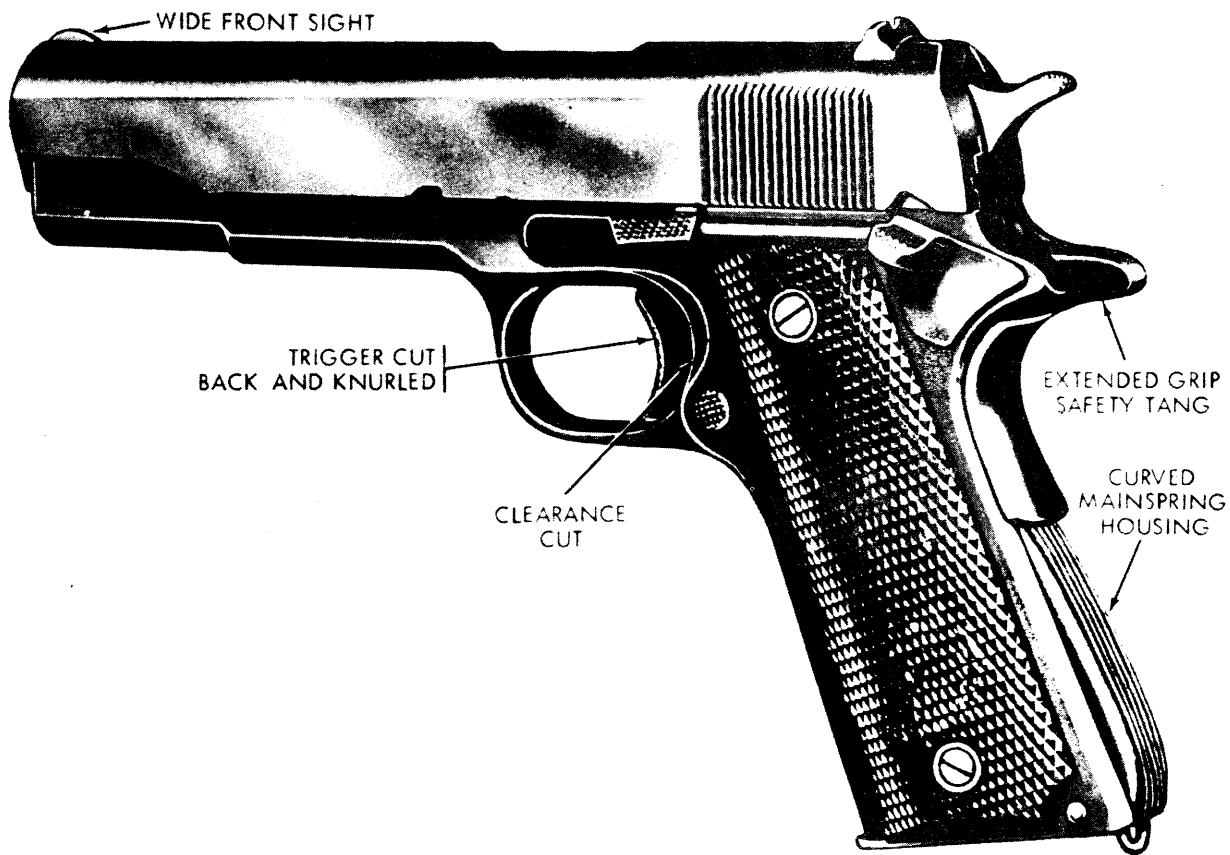

ORD F7526

Figure 2. Caliber .45 automatic pistol M1911A1 - left rear view.

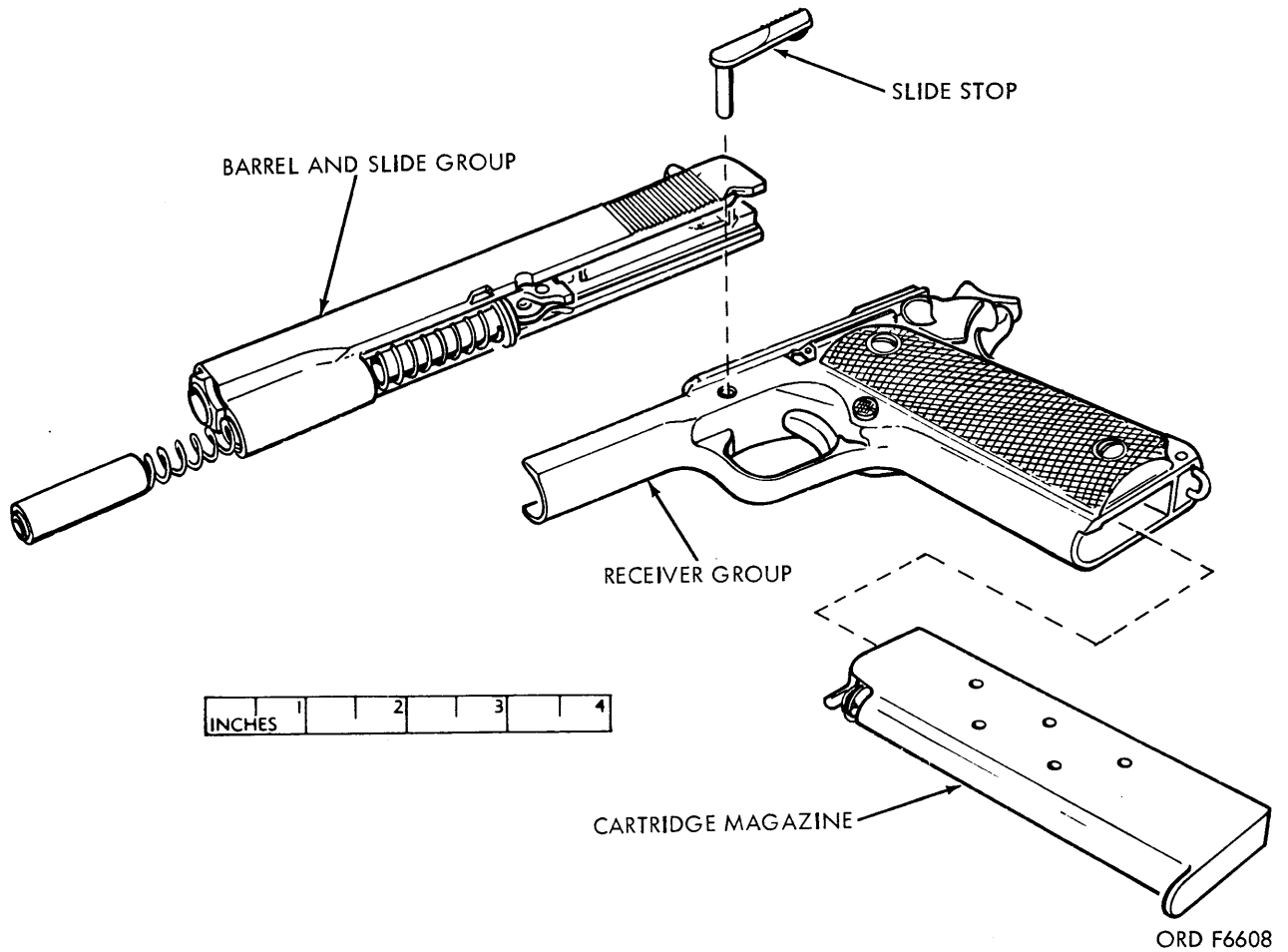

Figure 3. Caliber .45 automatic pistol M1911A1 - exploded view.

CHAPTER 2

PARTS, SPECIAL TOOLS, AND EQUIPMENT

6. General

Tools and equipment and maintenance parts over and above those available to the using organization are supplied to direct and general support maintenance units for maintaining and repairing the materiel.

7. Maintenance Parts

Maintenance parts are listed in TM 9-1005-211-35P, which is the authority for requisitioning replacements.

8. Common Tools and Equipment

Standard and commonly used tools and equipment having general application to this materiel are authorized for issue by tables of allowances and tables of organization and equipment.

9. Special Tools and Equipment

Special tools and equipment (table 1) and tool sets or kits are listed in and authorized for issue in TM 9-1005-211-35P. This tabulation contains only those special tools and equipment necessary to perform the operations described in this technical manual, is included for information only, and is not to be used as a basis for requisitions.

Table 1. Special Tools and Equipment

Item	Identifying No.	Reference		Use
		Fig.	Para.	
BRUSH, CLEANING, SMALL ARMS: M5 bore.	5504036	4	19b	To clean barrel bore and chamber.
FIXTURE, MEASURING, TRIGGER PULL:	7274758	5, 36	40c	To check trigger pull.

Item	Identifying No.	Reference		Use
		Fig.	Para.	
HOLSTER, PISTOL: M1916, hip (black).	7791466	6	-	To carry pistol on right hip.
HOLSTER, PISTOL: M7, shoulder (black).	7791527	6	-	To carry pistol under left arm.
ROD, CLEANING, SMALL ARMS: cal. .45, M4.	5564102	4	19b	Used with brush 5504036 to clean barrel bore and chamber.

10. Improvised Tools

The list of improvised tools in table 2 applies only to personnel performing direct and general support maintenance on the pistol. Illustrations giving dimensioned details are included to enable personnel to fabricate the tools if desired. The chief value of these tools is for maintenance personnel engaged in repairing a large number of weapons. The following data is for information only.

Table 2. Improvised Tools

Item	Reference		Use
	Fig.	Para.	
FIXTURE, riveting front sight.	7, 8, 21	32j	To rivet front sight in place on the slide.
TOOL, staking bushing.	9, 32	37b	To stake bushing in receiver.
TOOL, staking plunger tube.	10, 31	37b	To stake plunger tube in receiver.

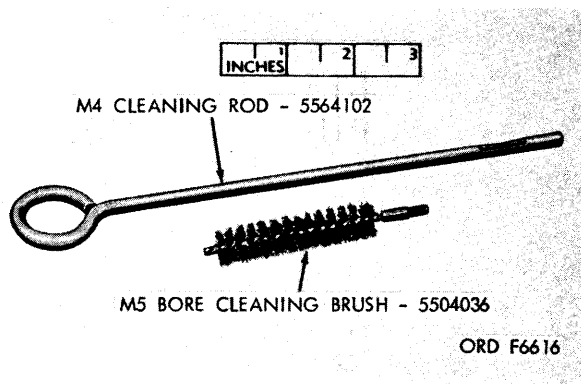

Figure 4. Special tools and equipment.

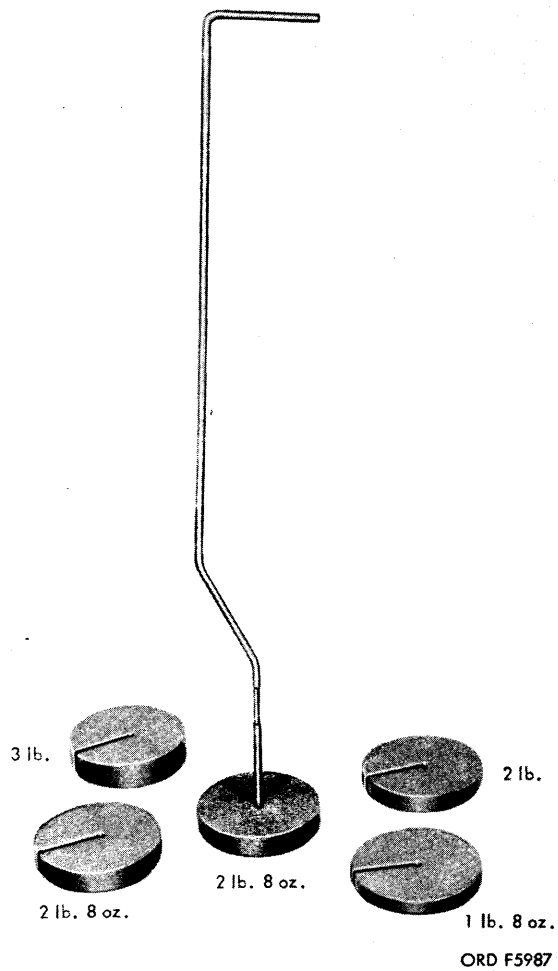
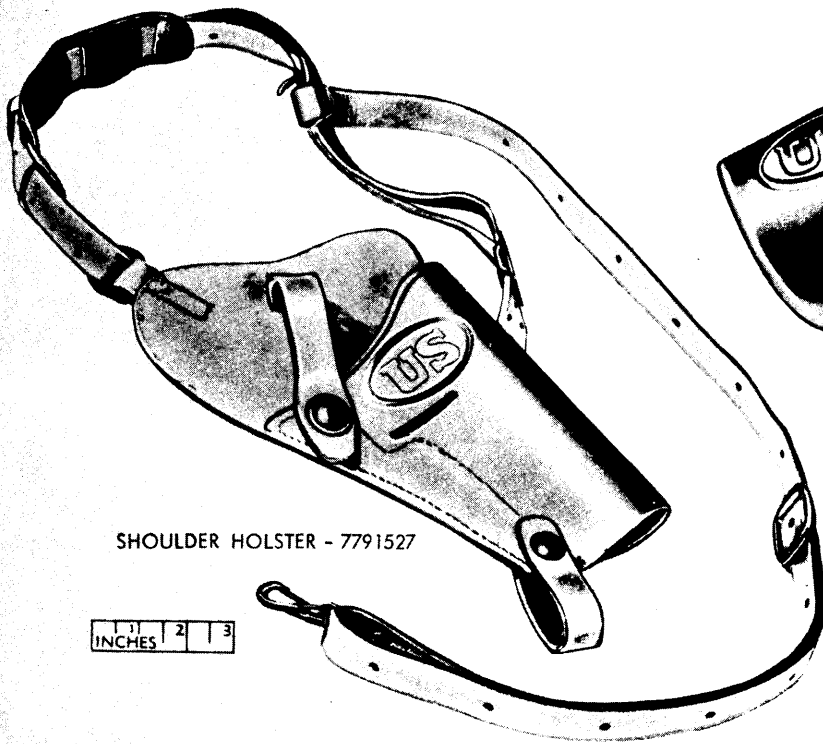
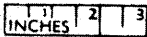

Figure 5. Trigger pull measuring fixture 7274758.



SHOULDER HOLSTER - 7791527



HIP HOLSTER - 7791466

ORD F7472

Figure 6. Hip and shoulder holsters.

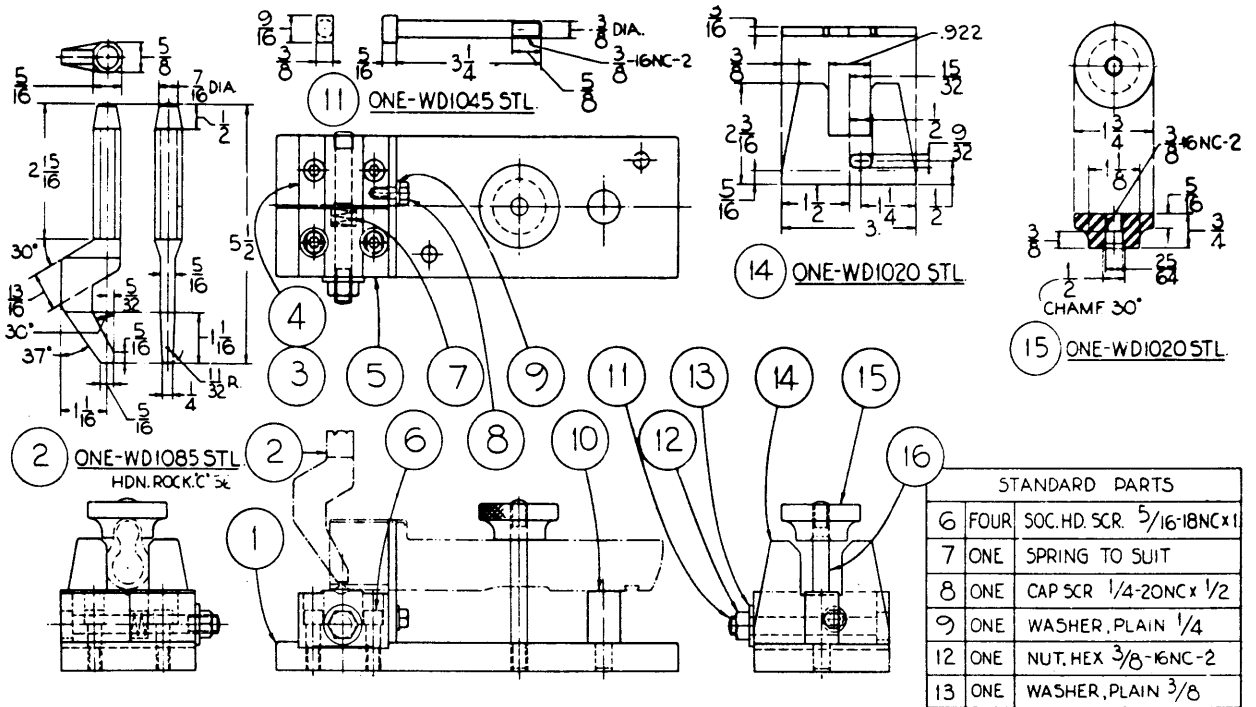

SHEET 1 OF 2

RA PD 91773

Figure 7. Improved fixture for riveting front sight (1 of 2).

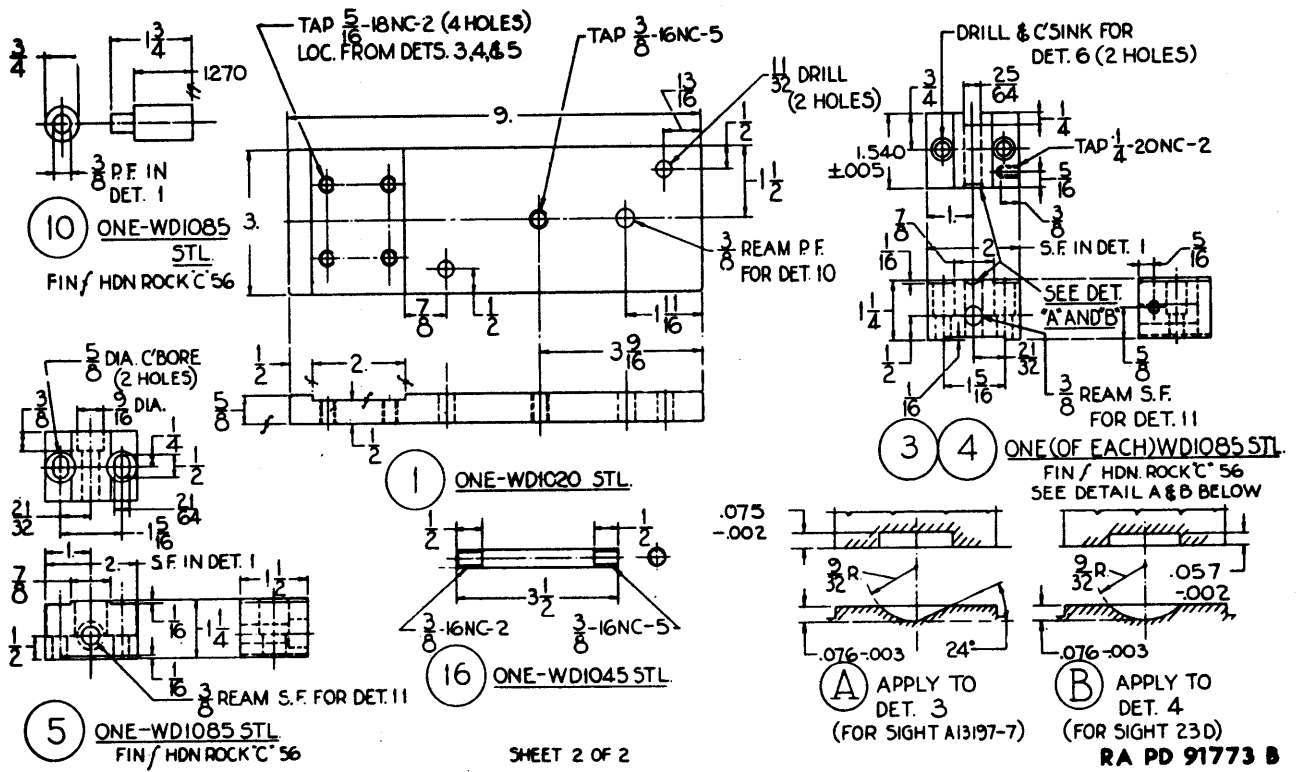

Figure 8. Improved fixture for riveting front sight (2 of 2).

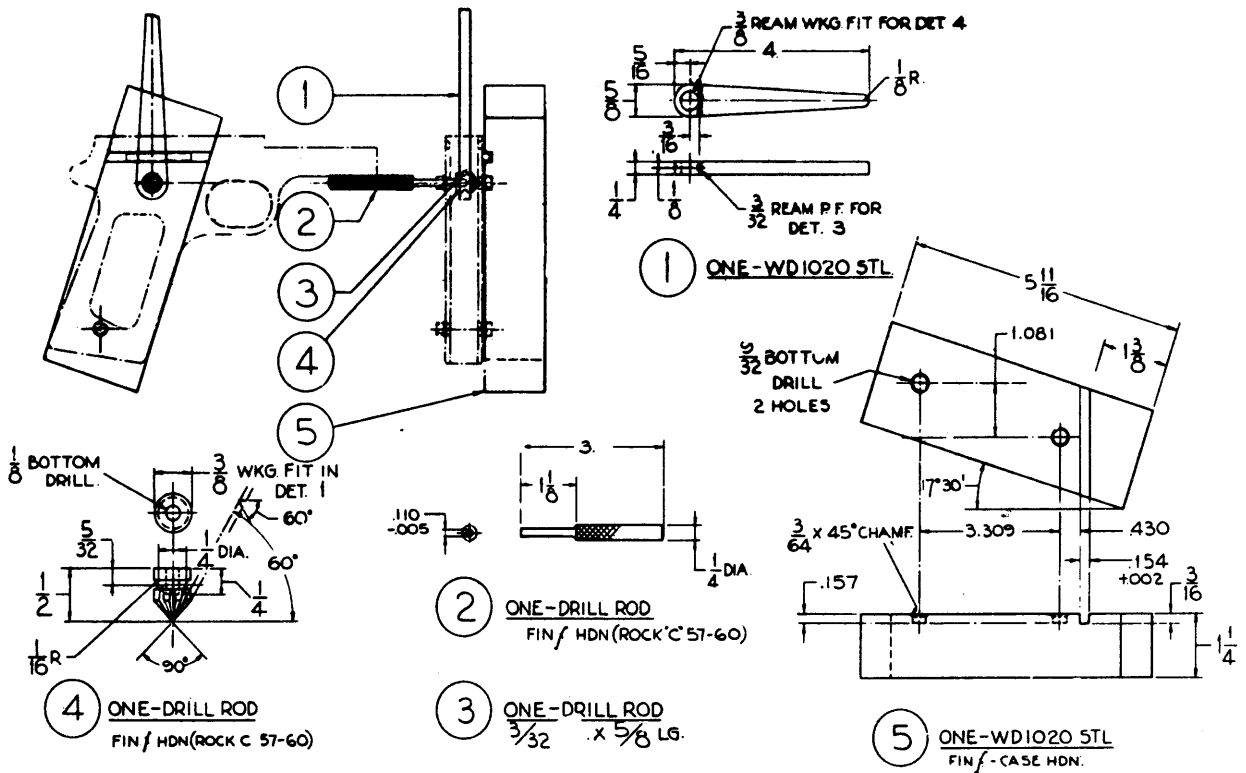

Figure 9. Improved tool for staking bushing.

CHAPTER 3

INSPECTIONS

Section I. GENERAL

11. Scope

This chapter provides specific instructions for the inspection by maintenance personnel of materiel in the hands of troops in the field, in Ordnance shops, and in alerted units scheduled for oversea duty. Troubleshooting information is incorporated wherever applicable as a normal phase of inspection.

12. Purpose of Inspection

Inspections are made for the purpose of (1) determining the condition of an item as to serviceability, (2) recognizing conditions that would cause failure, (3) assuring proper application of maintenance policies at prescribed levels, and (4) determining the ability of a unit to accomplish its maintenance and supply missions.

13. Categories of Inspection

In general, three categories of inspection are performed by direct and general support maintenance personnel.

a. *Inspection of Materiel in the Hands of Troops.*

- (1) *Spot check inspection.* This is an inspection performed on a percentage of materiel in order to ascertain the adequacy and effectiveness of organizational maintenance and supply. Included within this scope is inspection of equipment to detect incipient failures before un-serviceability occurs; inspection to ascertain the availability and use of technical and supply manuals and lubrication orders; inspection to determine the accuracy of records, authorized levels of equipment and supplies, practice of supply economy, preservation and safekeeping of tools, availability of repair parts and supplies, and knowledge

of the proper procedures for requisitioning supplies and equipment and follow-up thereon.

- (2) *Command maintenance.* Command maintenance inspections will be performed, at least, annually. The purpose of the inspection is to ascertain the serviceability of equipment, to predict maintenance and supply requirements, and to determine the adequacy of facilities and effectiveness of procedures. Information obtained during the inspection should indicate future requirements for depot maintenance and for replacement, as well as disclose immediate needs for maintenance and application of modification work orders. During inspection, correction of deficiencies will be made on the spot when practical. For additional information relative to these inspections and the forms to be used therewith, refer to AR 750-8.

b. *Ordnance Shop Inspection.*

- (1) *Initial inspection.* This is an inspection of materiel received in Ordnance shops for the purpose of determining the degree of repair and parts requirement. This includes determination of modification work orders to be applied.
- (2) *In-process inspection.* This is performed in the process of repairing the materiel, to insure that all parts conform to the prescribed repair standards, that the workmanship is in accordance with approved methods and procedures, and that deficiencies not disclosed by the initial inspection are found and corrected.
- (3) *Final inspection.* This is an acceptance inspection performed by

a final inspector after repair has been completed, to insure that the materiel is acceptable for return to user or storage.

c. Preembarkation Inspection of Materiel in Units Alerted for Oversea Movement. This inspection is conducted on materiel in alerted units scheduled for

oversea duty to insure that such materiel will not become unserviceable or worn out in a relatively short time. It prescribes a higher percentage of remaining usable life in *serviceable* materiel to meet a specific need beyond minimum serviceability.

Section II. INSPECTION PROCEDURES

14. General

Warning: Before starting an inspection, be sure to clear the weapon. Do not actuate the trigger until the weapon has been cleared. Inspect the chamber to insure that it is empty and check to see that no ammunition is in position to be introduced. Avoid having live ammunition in the vicinity of work area.

a. Check to see that the weapon has been cleaned of all corrosion preventive compound, grease, excessive oil, dirt, or foreign matter which might interfere with proper functioning or obscure the true condition of the parts.

b. Make an overall inspection of the weapon for general appearance, condition, operation, and manual functioning. Use dummy cartridges.

15. Inspection of Materiel in the Hands of Troops

a. *General.* Refer to AR 750-8 for responsibilities and fundamental duties of inspecting personnel, the necessary notice and preparations to be made, forms to be used, and general procedures and methods to be followed by inspectors. Materiel to be inspected includes organizational spare parts and equipment and the stocks of cleaning and preserving materials. In the course of this inspection, the inspector will accomplish the following:

- (1) Determine serviceability, i.e., the degree of serviceability, completeness, and readiness for immediate use, with special reference to safe and proper functioning of the materiel. If the materiel is found unserviceable or incipient failures

are disclosed, the deficiencies will be corrected on the spot or advice given as to corrective measures when applicable, or, if necessary, the materiel will be tagged for delivery to, and repair by Ordnance maintenance personnel.

- (2) Determine causes of mechanical and functional difficulties that troops may be experiencing and check for apparent results of lack of knowledge, misinformation, neglect, improper handling and storage, security, and preservation.
- (3) See that all authorized modifications have been applied, that no unauthorized alterations have been made, and that no work beyond the authorized scope of the unit is being attempted. Check the index in DA Pam 310-4 and the current MWO files for any MWO's printed after this publication.
- (4) Instruct the using personnel in proper preventive-maintenance procedures where found inadequate.
- (5) Check on completeness of the organizational maintenance allowances and procedures for obtaining replenishments.
- (6) Check serial number stamped on weapon for legibility.
- (7) Note general appearance. Check exterior of materiel for missing or broken parts.
- (8) Check storage conditions of general supplies and ammunition.
- (9) Initiate a thorough report on materiel on "deadline", with reasons

therefore, for further appropriate action.

- (10) Report to the responsible officer any carelessness, negligence, unauthorized modification, or tampering. This report should be accompanied by recommendations for correcting the unsatisfactory condition.

b. Specific. The specific groups and assemblies to be inspected for serviceability are listed in TB ORD 587 and also are applicable to preembarkation inspection.

c. Safety Tests. Perform the following safety tests as indicated in (1) through (4) below.

- (1) *Safety test (fig. 11).* With the pistol unloaded, cock the hammer and press the safety upward into the safe (locked) position. Grasp the grip so the grip safety is depressed and squeeze the trigger tightly three or four times. If the hammer falls, the safety must be replaced.
- (2) *Grip safety test (fig. 12).* With the pistol unloaded, cock the hammer and without depressing the grip safety point the pistol downward and squeeze the trigger three or four times. If the hammer falls because the grip safety is depressed by its own weight, the grip safety may be corrected by replacing sear spring.
- (3) *Half-cock position test (fig. 13 and 14).* With the pistol unloaded, draw

back the hammer until the sear engages the half-cock position notch. Then squeeze the trigger. If the hammer falls, the hammer or sear must be replaced or repaired. Draw the hammer back nearly to full cock position, do not squeeze trigger, and then let thumb slip off hammer. *The hammer should fall only to the half-cock notch.* Replace hammer when it falls past the half-cock position.

- (4) *Disconnecter test.*

- (a) With the pistol unloaded, cock the hammer. Push the slide group 1/4-inch to the rear (fig. 15) and hold in that position while squeezing trigger. Let slide group go

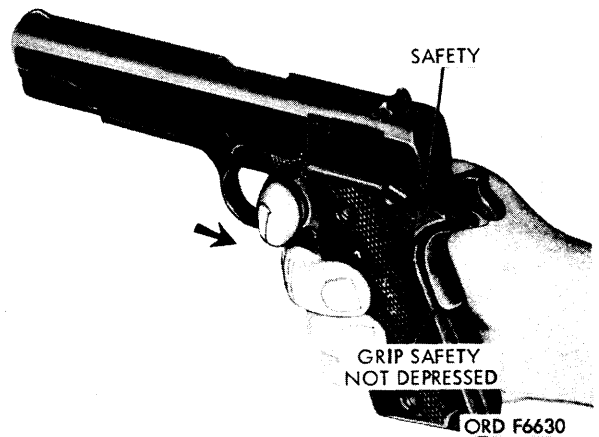

Figure 12. Grip safety test.

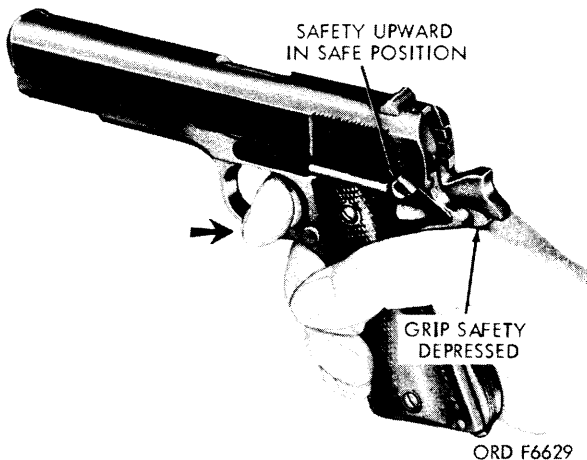

Figure 11. Safety test.

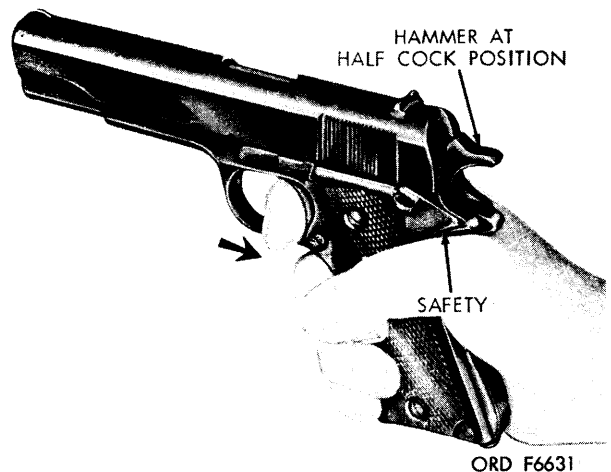
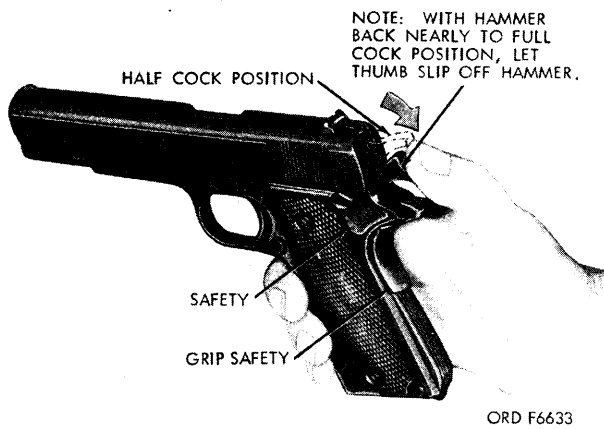

Figure 13. Half-cock position test (1 of 2).



ORD F6633

Figure 14. Half-cock position test (2 of 2).

forward, maintaining pressure on trigger. If the hammer falls, the disconnecter is worn and must be replaced.

- (b) Pull the slide group rearward until slide stop is engaged (fig. 15). Squeeze trigger and release slide group simultaneously. The hammer should not fall. If it does, replace the disconnecter.
- (c) Release the pressure on the trigger and then squeeze it. The hammer should then fall (fig. 15).

If it does not fall, check the sear spring for weakness. Also check for a faulty disconnecter which would prevent hammer from falling. The disconnecter should prevent the release of the hammer unless the slide group is in forward position, safely interlocked. This also prevents the firing of more than one shot at each squeeze of trigger.

16. Ordnance Shop Inspections

a. Initial Inspection. Inspection procedures outlined in paragraphs 14 and 15 apply also to initial shop inspection. If materiel received in shops is not tagged to indicate the nature of the repair, steps should be taken to determine the cause of unserviceability and the estimate of parts required.

b. Troubleshooting. Table 3 lists malfunctions, probable causes, and corrective actions. For troubleshooting within the scope of operator and organizational maintenance, refer to pertinent operator's and organizational maintenance manuals, covering materiel contained herein.

Table 3. Troubleshooting

Malfunction	Probable cause	Corrective Action
FAILURE TO FEED. The top cartridge in the magazine is not properly positioned.	Dirty or dented magazine -- Weak or broken magazine spring. Worn or broken magazine catch. Improper assembly, magazine spring backwards.	Clean magazine if dirty. Replace magazine if dented. (para. 25, fig. 16). Replace magazine. (para. 25, fig. 16). Replace magazine catch. (para. 37o, fig. 30). Assemble spring correctly. (para. 27).
FAILURE TO CHAMBER.	Bent magazine follower---- Obstruction or dirty chamber. Weak recoil spring -----	Replace magazine. (para. 25, fig. 16). Clean chamber. (para. 19b). Replace recoil spring. (para. 32 f, fig. 18).
FAILURE TO LOCK. The barrel locking ribs do not interlock with the locking recesses in the slide.	Lack of lubrication of operating parts. Burred or dirty barrel locking ribs or locking recesses. Weak recoil spring -----	Apply oil to parts, lightly. (para. 23b). Stone rough edges, clean barrel locking ribs. (para. 32a). Replace recoil spring. (para. 32f, fig. 18).
FAILURE TO FIRE. The hammer falls but the primer of the cartridge is not ignited.	Broken barrel link----- Broken firing pin ----- Bent or broken hammer strut.	Replace link. (para. 32d, fig. 19). Replace firing pin. (para. 32e, fig. 20). Replace strut. (para. 37e, fig. 27).

Table 3. Troubleshooting - Continued

Malfunction	Probable cause	Corrective Action
<p>FAILURE TO UNLOCK. The barrel locking ribs do not disengage from the recesses in the slide.</p> <p>FAILURE TO EXTRACT. The cartridge case is not removed from the chamber.</p> <p>FAILURE TO EJECT. The cartridge case is not ejected from the pistol.</p> <p>FAILURE TO COCK.</p> <p>MISCELLANEOUS. Two shots or more fired in succession by one trigger squeeze. Hammer jumps out or fails to cock.</p>	Weak mainspring -----	Replace mainspring. (para. 37k, fig. 28).
	Broken barrel link-----	Replace barrel link. (para. 32d, fig. 20).
	Broken pin-----	Replace pin. (para. 32d, fig. 20).
	Broken barrel link lugs----	Replace barrel. (para. 32b, fig. 20).
	Broken or worn extractor--	Replace extractor. (para. 32g, fig. 20).
	Dirty or pitted chamber ---	Clean chamber if pitting in chamber is excessive. Replace barrel. (para. 32b, fig. 20).
	Faulty extractor, does not position the cartridge case for ejection.	Replace extractor. (para. 32g, fig. 20).
	Broken ejector -----	Replace ejector. (para. 37b, fig. 32).
	Worn cock notch-----	Replace hammer. (para. 37d, fig. 28).
	Worn sear -----	Replace sear. (para. 37f, fig. 30).
Defective sear spring -----	Replace spring. (para. 37g, fig. 29).	
Worn or broken disconnecter.	Replace disconnecter. (para. 37h, fig. 30).	
Worn cock notch-----	Replace hammer. (para. 37d, fig. 28).	
Hammer and sear pin assembled from wrong side of receiver.	Assembly hammer and sear pin correctly. (para. 38, figs. 28 and 29).	

c. In-Process Inspection. Detailed instructions for in-process inspection of the materiel are contained in the repair chapter together with applicable repair instructions.

d. Final Inspection. Detailed instructions for final inspection of materiel in direct and general support maintenance shops are contained in chapter 6.

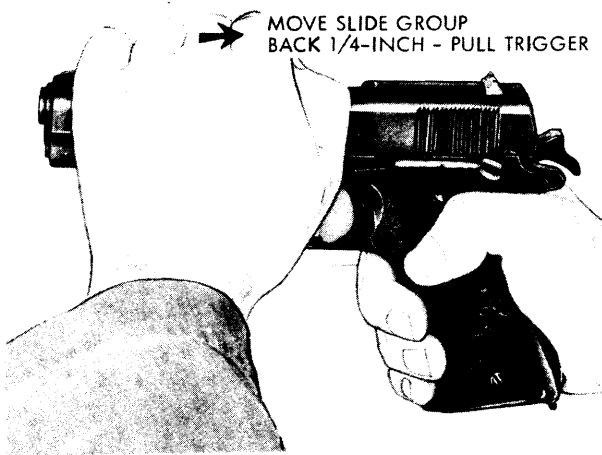

POSITIONING SLIDE GROUP TO DETERMINE IF DISCONNECTOR IS WORN.

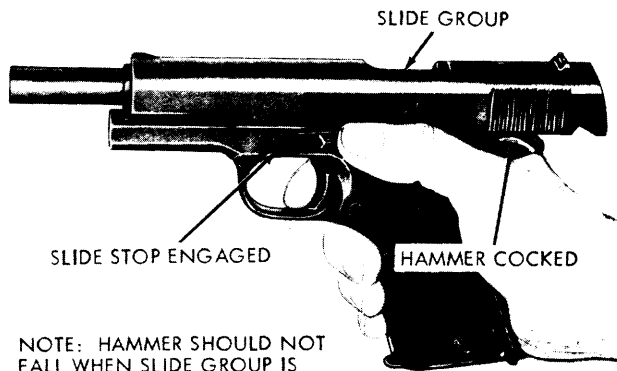

NOTE: HAMMER SHOULD NOT FALL WHEN SLIDE GROUP IS RELEASED.

SLIDE GROUP IN REARWARD POSITION, PREPARING TO RELEASE SLIDE STOP.

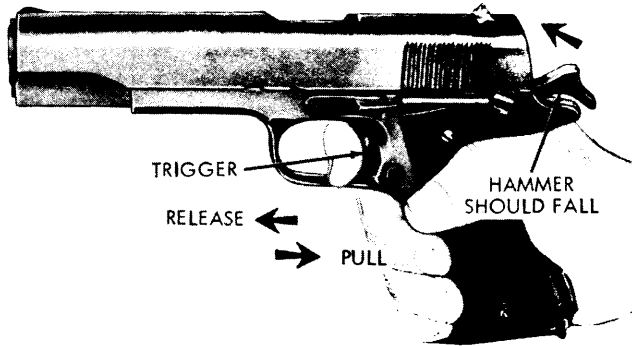

SLIDE GROUP IN FORWARD POSITION PRIOR TO TESTING HAMMER.

ORD F7630

Figure 15. Disconnecter test.

CHAPTER 4

GENERAL MAINTENANCE

17. General

This chapter provides the necessary instructions on the general maintenance procedures to follow. The following methods and procedures given in this chapter are to be carefully observed during repair operations. This chapter includes the disassembly and assembly procedures, replacement of parts, use of tools, cleaning, finished surfaces, removal of burs, and instructions on lubrication.

18. General Repair Methods

a. Disassembly and Assembly Procedures.

- (1) In disassembling a unit, remove the major subassemblies and assemblies whenever possible. Subassemblies may be disassembled, as necessary, into individual parts.
- (2) During assembly, subassemblies should be assembled first, then installed to form a complete unit. Lubricate all component parts lightly before assembling.
- (3) Complete disassembly of a unit is not always necessary in order to make a required repair or replacement. Good judgment should be exercised to keep disassembly and assembly operations to a minimum.

b. Replacement of Parts.

- (1) When assembling a unit, replace all pins when necessary. Replace grip screws or bushings when damaged.
- (2) All springs will be replaced if they are broken, bent, cracked or if they fail to function properly.
- (3) If a required new part is not available, a reconditioned used part may be substituted. Such reconditioned used parts will be examined carefully to determine their serviceability.

c. Use of Tools

- (1) Care must be exercised to use tools that fit and are suitable for the task to be performed in order to avoid unnecessary mutilation of parts and/or damage to tools.
- (2) Special tools are listed in table 1 and are provided for the maintenance of the materiel. These tools will be used only for the purpose for which they are intended.
- (3) Keep tools clean and work with clean parts. Normal rules of good housekeeping must be observed.

19. Cleaning

a. As assemblies are removed and disassembled, component items should be placed in a wire basket and cleaned thoroughly of all grease, oil, water and dirt, using dry cleaning solvent (SD). Dry thoroughly with clean wiping cloths and oil lightly using general purpose lubricating oil (PL special).

b. Clean the barrel bore, chamber, and all parts that come in contact with powder residues, using solvent cleaning compound (PD 126). Cleaning rod M4, 5564102 (fig. 4) and small arms cleaning brush M5, 5504036 (fig. 4) are used to clean the barrel bore. Saturate brush with PD 126 and run through barrel. Remove brush, clean the rod, insert two swabs in slot of rod and dry the bore thoroughly or until swabs appear clean after running through bore. Then use one swab saturated with PL special to oil inside of bore lightly and all exterior surfaces to prevent corrosion or rust.

c. On those component parts which contain a hard carbon residue, it may be necessary to clean these parts with carbon removing compound (P-C-111A). Cleaning instructions are as follows:

Warning: Avoid skin contact. The compound should be washed off thoroughly with running water if it comes in contact with

the skin. A good lanolin base cream, after exposure to compound, is helpful. The use of gloves and protective equipment is recommended.

- (1) Using a suitable container, fill with fresh compound.
- (2) Before soaking components remove loose grease, dirt and oil from parts as indicated in paragraph 19a. Immerse parts, containing carbon residue, in container.
- (3) Allow barrel to soak for 2 hours or until all traces of carbon have been removed.
- (4) Rinse with water, kerosene, or solvent. To effectively remove carbon, brush with a stiff bristle brush under running water.
- (5) Wipe the parts dry and oil.

Note: P-C-111A is considered a supplement for use in direct and general support maintenance levels only in extreme cases and not as a substitute for PD 126.

d. Clean receiver, using dry cleaning solvent (SD).

e. On components that contain an accumulation of light rust, use a clean cloth moistened with PD 126. If this does not suffice, use crocus cloth. Make certain it does not scratch or alter the finished surfaces. Remove all dirt and abrasives; oil surfaces before assembling parts.

f. New material and component parts, received from storage for immediate use, may have heavy accumulations of grease. Place material or components in wire basket and lower in vapor degreasing vat or wash in dry cleaning solvent (SD). Dry thoroughly as indicated in paragraph 19a and oil. Lubricate as specified in paragraph 23b.

g. For cleaning instructions of Ordnance materiel, refer to TM 9-208-1.

20. General Precautions in Cleaning

a. Dry cleaning solvent (SD) is flammable and should not be used near an open flame. Fire extinguishers should be readily available when using these materials. In addition, they evaporate quickly and have a drying effect on the skin. When used without rubber gloves, they may cause

cracks in the skin, and in the case of some individuals, a mild irritation or inflammation. Use only in well-ventilated places.

b. The use of diesel fuel oil, gasoline or benzene (benzol) for cleaning the weapon is prohibited.

c. Store solvent cleaning compound (PD 126) in a warm place, if practical. Do not dilute or add antifreeze.

Note: Sandblasting is permissible on nonworking surfaces for removal of dirt and rust.

21. Finished Surfaces

a. All treated surfaces will be refinished to match the appearance of new parts.

b. For detailed information on finished surfaces, refer to TM 9-1861.

22. Removal of Burs, Screwheads and Working Surfaces

a. During the entire life of the pistol, polishing and stoning are necessary to relieve friction and to remove burs caused by usage. Burs on screwheads and like surfaces should be removed with a fine file or stone. Burs on such working surfaces as the receiver sliding rails, receiver housing areas and bearings should be removed with a file or stone and polished with crocus cloth.

Caution: Care will be exercised to stone or file evenly and lightly and not remove more metal than absolutely necessary to maintain correct contours. Critical dimensions of parts or assemblies must not be altered in any way that would affect the functioning or interchangeability of parts.

b. Rough spots caused by scores, galling, gouges and rust pits will be smoothed to enable all parts to operate normally. The finish of the repaired component will be approximately that of the original finish.

23. Lubrication

a. Make certain all metal parts are cleaned and dried thoroughly in accordance with instructions contained in paragraph 19.

b. All metal parts will be lubricated by applying a light coat of general purpose lubricating oil (PL special). As a part of all assembly and installation operations,

lubricate sliding surfaces to reduce friction and assure free movement.

c. Lubrication and preservation materials are listed in TM 9-1005-211-12P/2.

CHAPTER 5

REPAIR

Section I. CARTRIDGE MAGAZINE

24. Removal

Refer to figure 16 for removal of cartridge magazine.

25. Disassembly

Detailed disassembly of cartridge magazine is not necessary for inspection. If any part is unserviceable, replace magazine.

26. Cleaning

Refer to paragraph 19 for cleaning.

27. Inspection

Inspect the exterior of magazine (fig. 17) for burs or other damage. Check for spring tension and for the correct assembly of magazine spring.

Note. Small spring loop must be up and to the front.

28. Installation

Refer to figure 16 for installation of magazine.

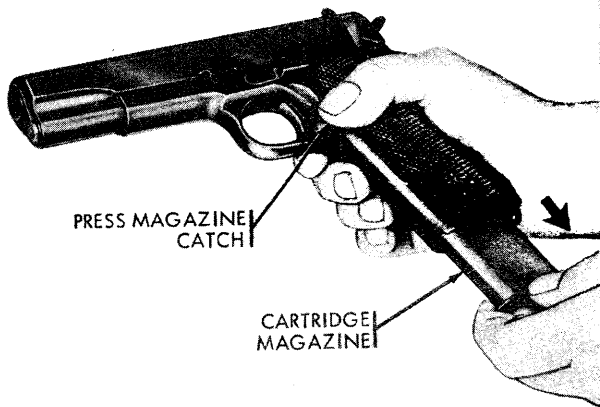

A - REMOVING MAGAZINE.

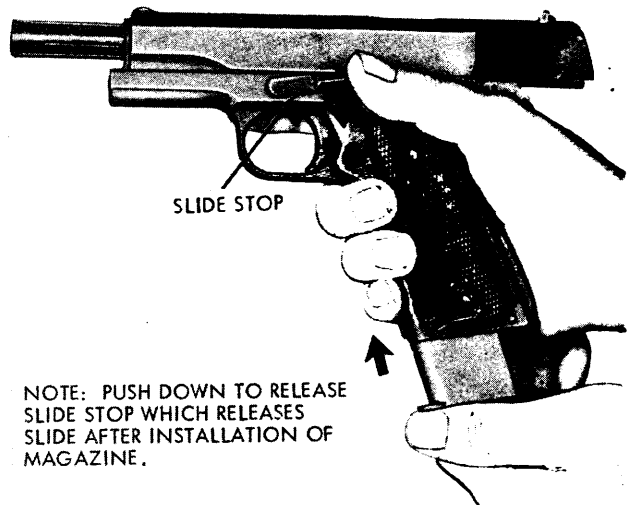

NOTE: PUSH DOWN TO RELEASE SLIDE STOP WHICH RELEASES SLIDE AFTER INSTALLATION OF MAGAZINE.

B - INSTALLING MAGAZINE.

ORD F6610

Figure 16. Remove/install cartridge magazine.

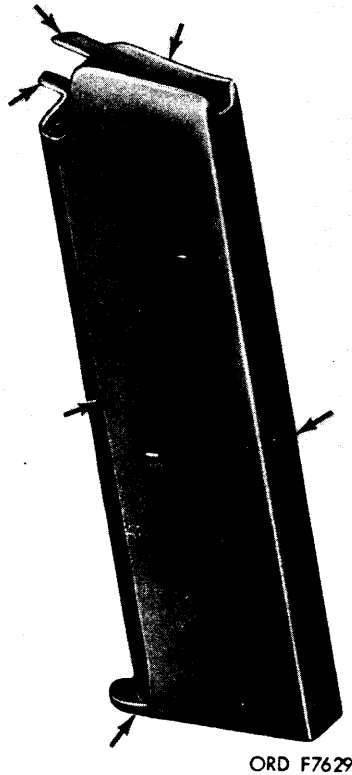

ORD F7629

Figure 17. Cartridge magazine inspection points.

Section II. BARREL AND SLIDE GROUP

29. Disassembly

Note. White arrows, shown on illustrations, indicate removal or disassembly and black arrows assembly or installation.

Refer to figures 18 thru 21 for disassembly of barrel and slide group.

Warning: Wherever springs are found to be under tension or pressure, extreme care should be exercised when removing components. Keep the finger and thumb over applicable components to prevent injury to personnel or loss of parts.

30. Cleaning

Refer to paragraph 19 for cleaning.

31. Inspection (fig. 22)

a. Inspect the barrel for burrs on the exterior and interior rim of the muzzle. In-

spect the barrel for pitting, bulges, and sharpness of lands (figs. 23 through 25).

b. Barrel must be straight, as determined visually, clean and free of corrosion.

c. Pits in the chamber are allowable if they are not large enough to cause extraction difficulties.

d. Pits as wide as a land or groove and less than three-eighths inch are allowable. Barrels containing pits as indicated in figures 23 thru 25 will be rejected.

e. Scattered or uniformly fine pits or fine pits in a densely pitted area are allowable. Tool marks or scratches are accepted, regardless of length. Tool marks will appear on lines running laterally in the grooves or may run spirally across the top of lands.

f. Definitely ringed bores or bores ringed sufficiently to bulge the outside

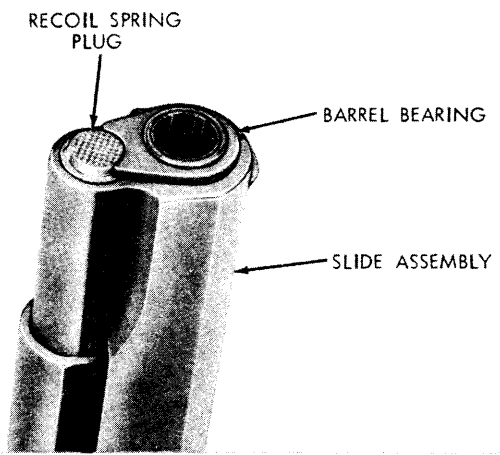

VIEWING MUZZLE END OF PISTOL.

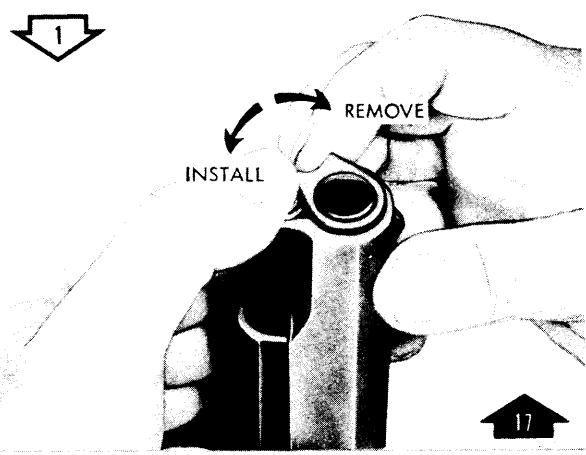

COMPRESS RECOIL SPRING PLUG AND ROTATE BARREL BEARING.

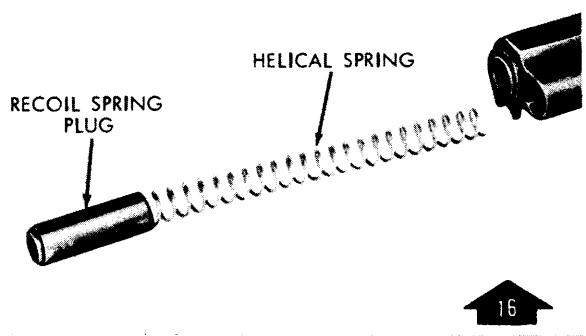
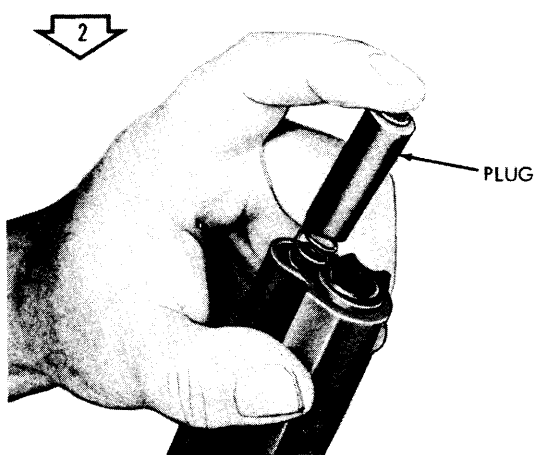

REMOVE/INSTALL RECOIL SPRING PLUG AND SPRING.

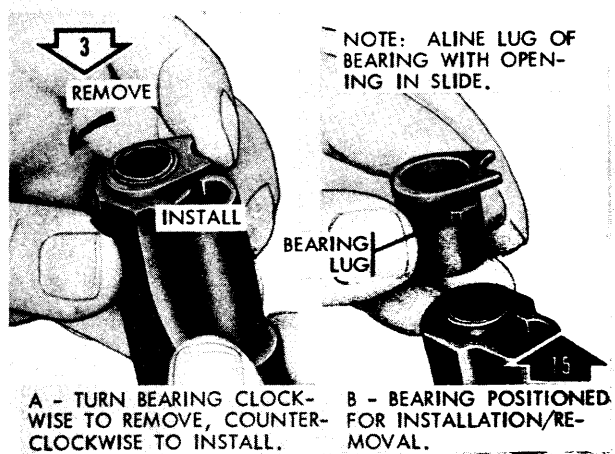

A - TURN BEARING CLOCKWISE TO REMOVE, COUNTERCLOCKWISE TO INSTALL. B - BEARING POSITIONED FOR INSTALLATION/REMOVAL.

REMOVE/INSTALL BARREL BEARING.



COCK HAMMER FOR REMOVING/INSTALLING SLIDE GROUP.

ORD F6611

Figure 18. Disassembly/assembly of barrel and slide group (1 of 4).

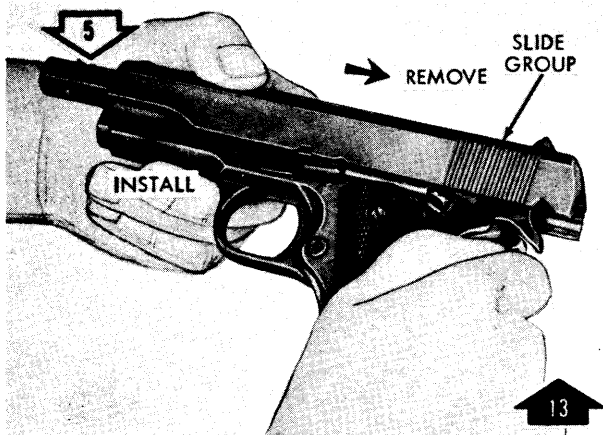

POSITION SLIDE GROUP.

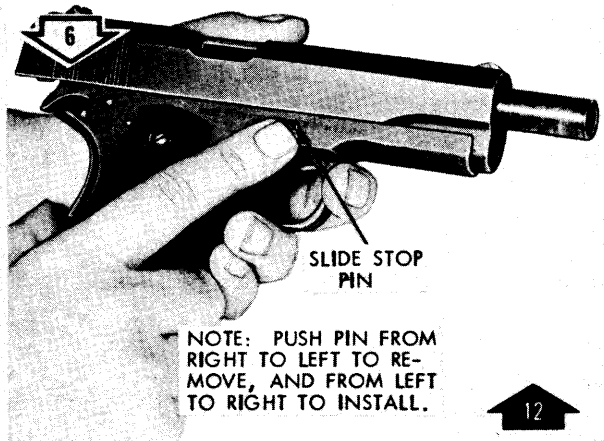

UNSEAT/SEAT PIN PORTION OF SLIDE STOP.

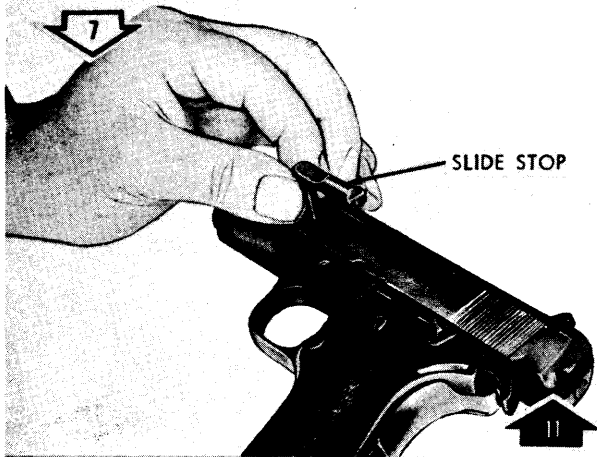

REMOVE/INSTALL SLIDE STOP.

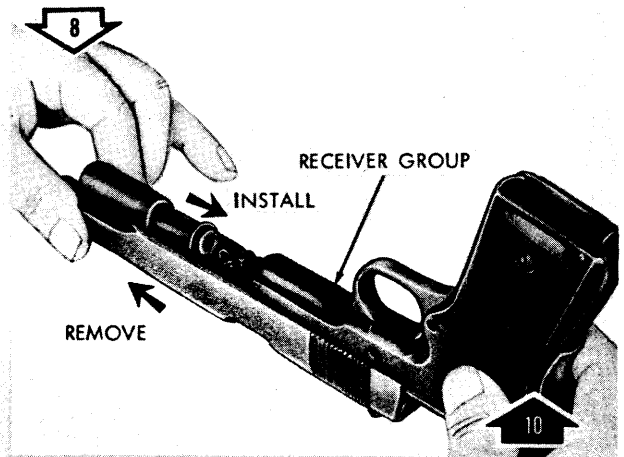

REMOVE/INSTALL SLIDE GROUP FROM RECEIVER GROUP.

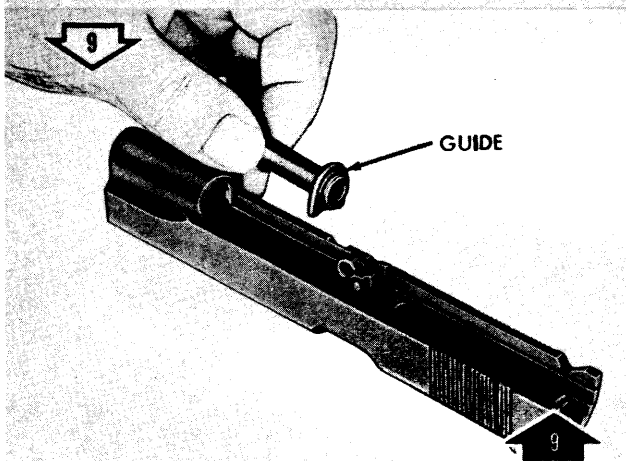

REMOVE/INSTALL RECOIL SPRING GUIDE.

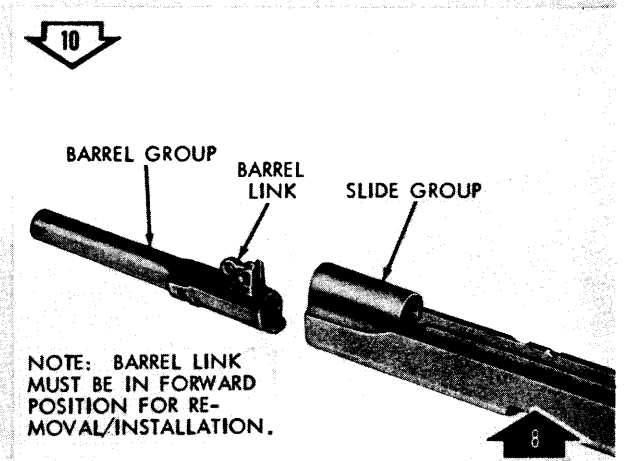

REMOVE/INSTALL BARREL GROUP.

ORD F6612

Figure 19. Disassembly/assembly of barrel and slide group (2 of 4).

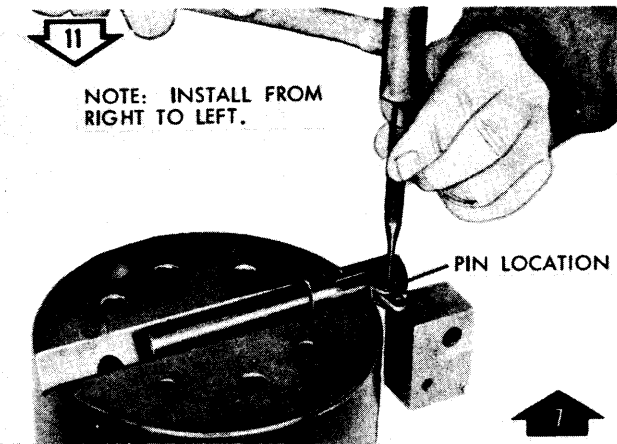

NOTE: INSTALL FROM RIGHT TO LEFT.

PIN LOCATION

REMOVE/INSTALL BARREL LINK PIN.

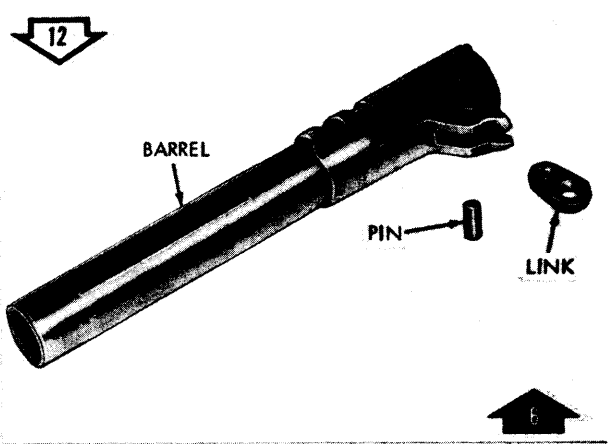

BARREL

PIN

LINK

REMOVE/INSTALL BARREL LINK.

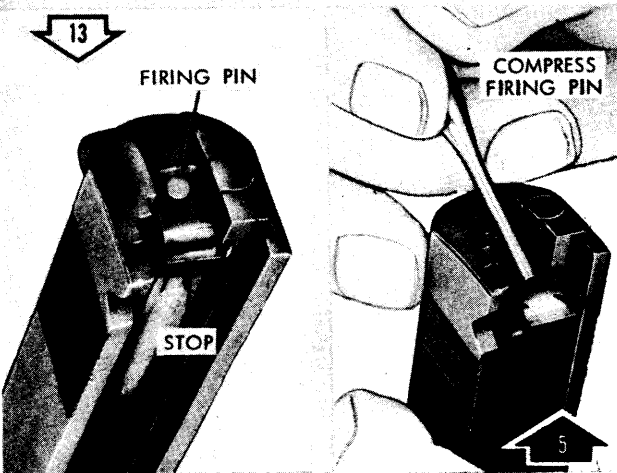

FIRING PIN

COMPRESS FIRING PIN

STOP

A - FIRING PIN AND STOP. B - COMPRESS FIRING PIN TO REMOVE/INSTALL STOP.

REMOVE/INSTALL FIRING PIN STOP.

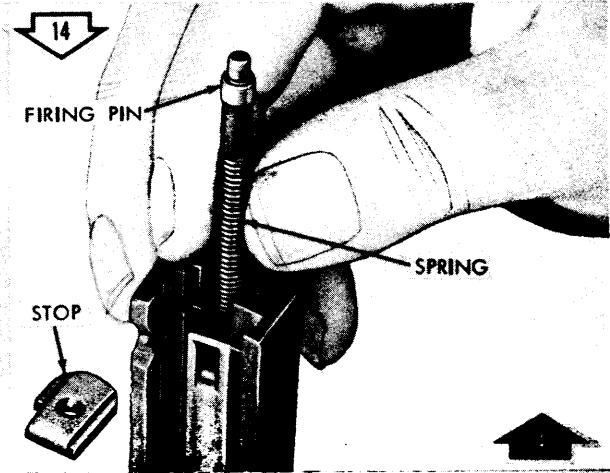

FIRING PIN

STOP

SPRING

REMOVE/INSTALL FIRING PIN AND FIRING PIN SPRING.

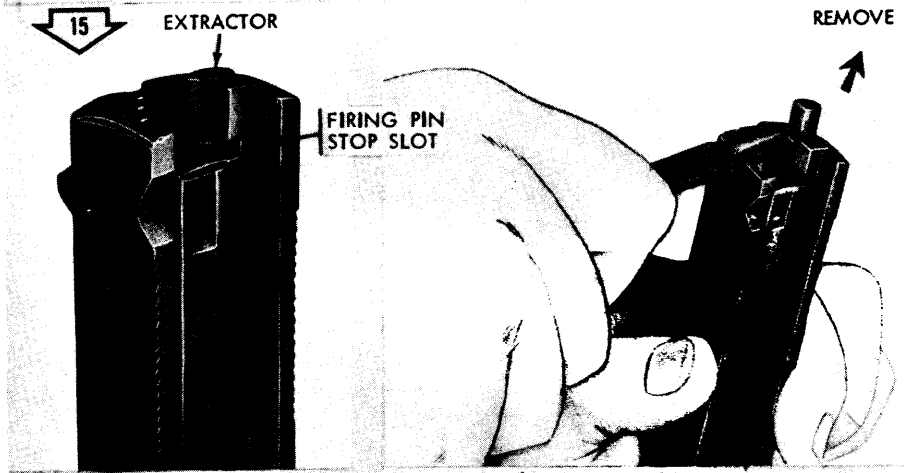

EXTRACTOR

FIRING PIN STOP SLOT

REMOVE

A - CORRECT LOCATION OF EXTRACTOR AT FIRING PIN STOP SLOT.

B - UNSEAT/SEAT EXTRACTOR.

REMOVE/INSTALL CARTRIDGE EXTRACTOR.

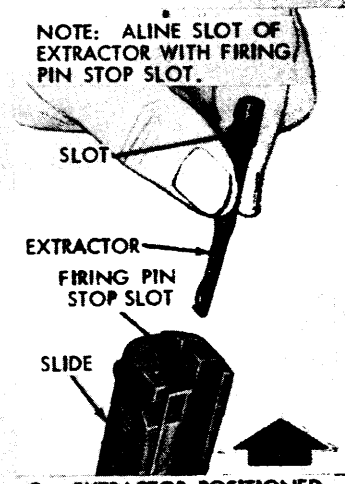

NOTE: ALINE SLOT OF EXTRACTOR WITH FIRING PIN STOP SLOT.

SLOT

EXTRACTOR
FIRING PIN STOP SLOT

SLIDE

C - EXTRACTOR POSITIONED.

ORD F6613

Figure 20. Disassembly/assembly of barrel and slide group (3 of 4).

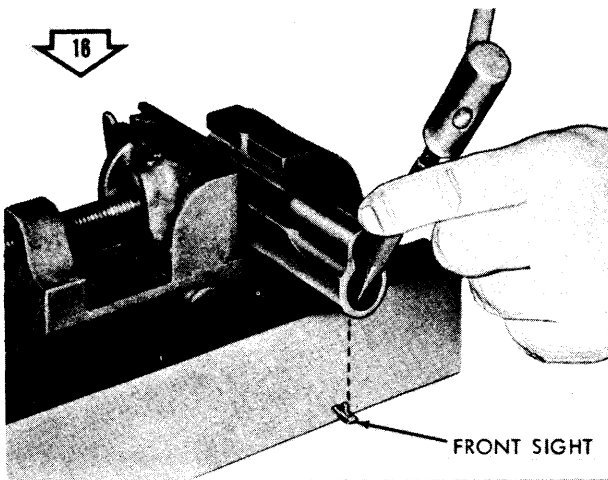

REMOVE FRONT SIGHT.

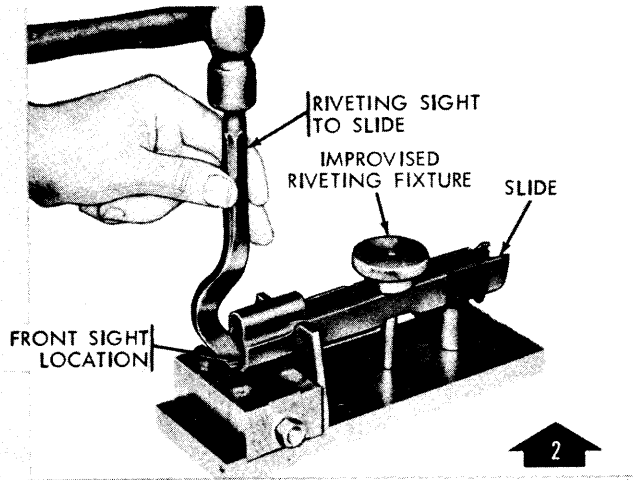

INSTALL FRONT SIGHT.

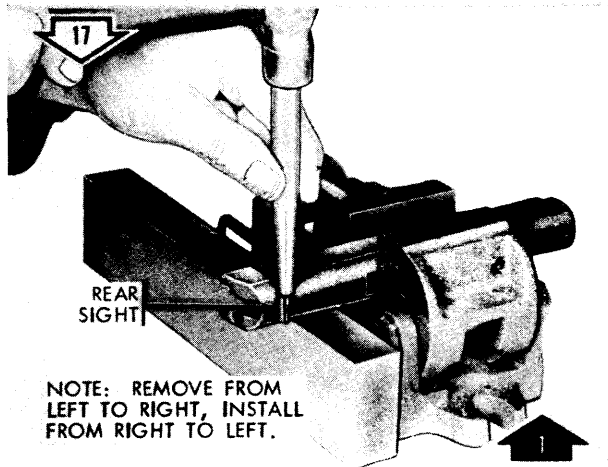

REMOVE/INSTALL REAR SIGHT.

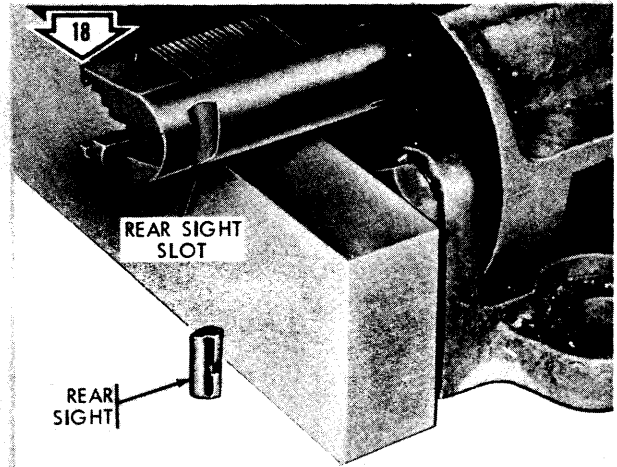

REAR SIGHT REMOVED.

ORD F6614

Figure 21. Disassembly/assembly of barrel and slide group (4 of 4).

surface of the barrel are cause for rejection. However, faint rings or shadowy depressions do not indicate an unserviceable barrel and should not be cause for rejection.

g. Inspect the barrel bearing for burrs and excessive wear.

h. Inspect slide for breaks or cracks, especially around the ejector port. Inspect the interior grooves and ejector port of slide for excessive wear and burrs. Check for loose front or rear sights.

i. Inspect the firing pin for wear or shortness. The pin, as manufactured, has an overall length of 2.290 to 2.296 inches.

j. Inspect the recoil and firing pin springs for weakness or breakage. The free length of recoil spring should be approximately 6-1/2 inches.

k. Examine the extractor for wear, weakness, broken lip or deformation.

l. Inspect the recoil spring plug, recoil spring guide, firing pin stop, barrel link and pin for burrs and distortions.

32. Repair

a. Remove burrs on exterior and interior rim of barrel and barrel chamber by using a fine stone.

b. Replace barrel if cracked, bulged or

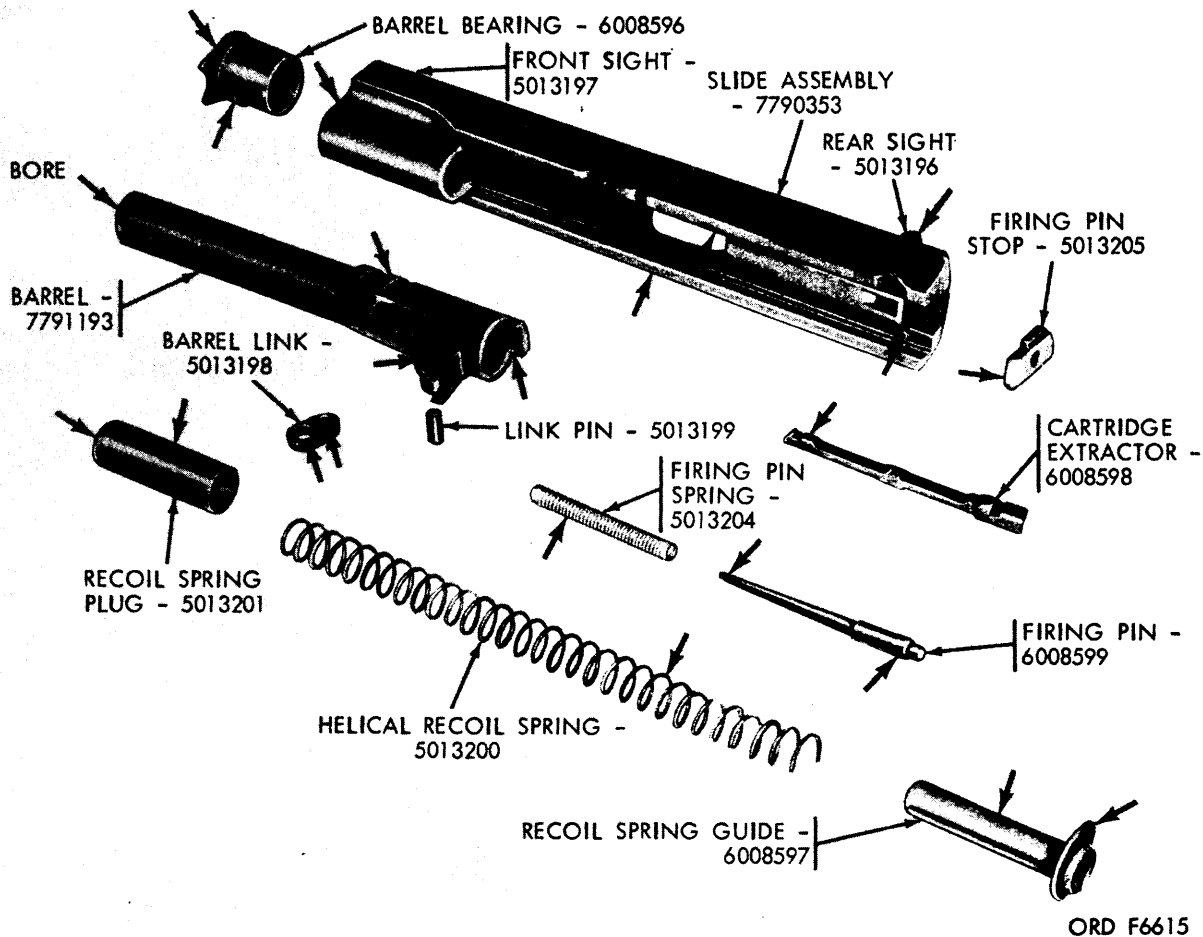

ORD F6615

Figure 22. Barrel and slide group - inspection points.

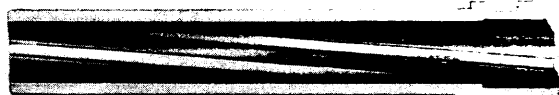

ORD F6619

Figure 23. Interior of barrel showing slight pitting and sharp lands - cutaway view.



ORD F6620

Figure 24. Interior of barrel showing pitting and dull lands - cutaway view.



ORD F6621

Figure 25. Interior of barrel showing pitting, worn lands and burs - cutaway view.

pits are larger than the width of a land or groove or more than three-eighths inch in length. Also, replace barrel if link lugs are damaged or broken.

c. Replace barrel bearing if worn. Remove burs using a fine stone.

d. Replace barrel link and/or pin if worn, deformed or damaged.

e. Replace worn, damaged or short firing pin.

f. Replace cracked or weak recoil and/or firing pin spring.

g. Replace extractor if worn or lip is broken.

h. Remove burs from recoil spring plug and guide. Replace, if worn or damaged.

i. Replace front or rear sights if damaged to such an extent that the contour of either sight would be insufficient for accurate sighting of weapon.

j. If front sight is loose, restake, using riveting fixture.

k. If rear sight is loose, remove sight, peen top portion of dovetail slot and replace rear sight, using brass drift (fig. 21).

33. Assembly

Refer to figures 18 thru 21 for assembly of barrel and slide group.

Note. When assembling firing pin and recoil springs, small loop of springs will be to the rear.

Section III. RECEIVER GROUP

34. Disassembly

Refer to figures 26 thru 32 for disassembly of receiver group.

35. Cleaning

Refer to paragraph 19 for cleaning of receiver group.

36. Inspection

a. Inspect the trigger for burs and wear (fig. 33). Inspect the half-cock position notch and full-cock notch of hammer for cracks, chips or wear. Make certain the hammer strut is not bent or cracked.

b. Inspect the sear for worn or chipped tips or worn lugs.

c. Inspect the sear spring for broken leaves, cracks and tension.

d. Inspect disconnecter for burs and wear.

e. Inspect the grip safety for burs, wear and cracks on the tip which engages the trigger.

f. Inspect the pin portion and lug of safety for wear or damage.

g. Inspect the helical compression housing spring (fig. 34) for cracks and tension.

h. Inspect mainspring cap pin, detent plunger, and straight-headed pin for burs, wear or damage.

i. Inspect for bent or worn mainspring housing pin and spring pin.

j. Inspect slide stop, slide stop plunger and safety plunger for burs, wear or damage.

k. Inspect magazine catch and magazine catch lock for burs and wear. Check magazine catch spring for tension and damage.

l. Inspect helical compression spring (housing) for burs on mating surfaces and

lanyard loop for being bent, worn or damaged.

m. Inspect grips for cracks and worn checkering.

n. Inspect the receiver housing (fig. 35) for wear or burs in the slide mating grooves. Inspect the receiver for deformation. Check to see that the plunger tube, ejector, ejector pin, and grip screw bushings are not burred or worn. Check the mainspring housing mating grooves in the receiver for burs. Check slide stop notch for oversize or wear.

37. Repair

a. Remove burs from slide mating surfaces of receiver housing and mainspring housing mating surfaces, using a fine stone.

b. Replace slide stop plunger and safety plunger, and ejector if worn or damaged. Replace plunger tube using staking plunger tube tool. Replace all bushings that have been removed from receiver housing, using staking bushing tool.

c. Remove burs from trigger, replace if worn or damaged.

d. Replace hammer if cracked, chipped or worn.

e. Replace hammer strut if bent, cracked, worn or damaged.

f. Replace sear if lugs are worn and tips are worn or chipped.

g. Replace sear spring if leaves are broken or cracked, or tension is weak.

h. Remove burs from disconnecter, replace if worn or damaged.

i. Remove burs from grip safety, replace if cracked or worn on tip.

j. Replace safety if worn or damaged.

k. Replace the helical compression

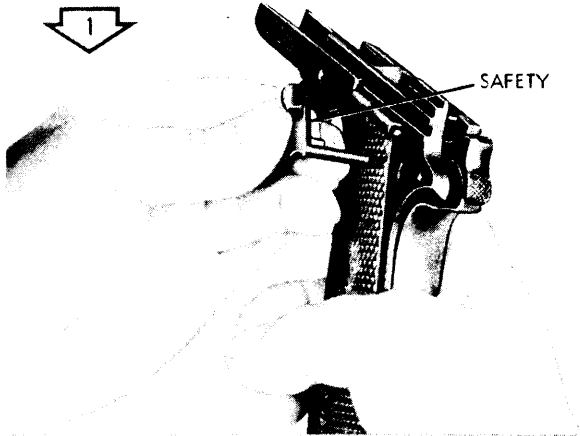

REMOVE SAFETY.

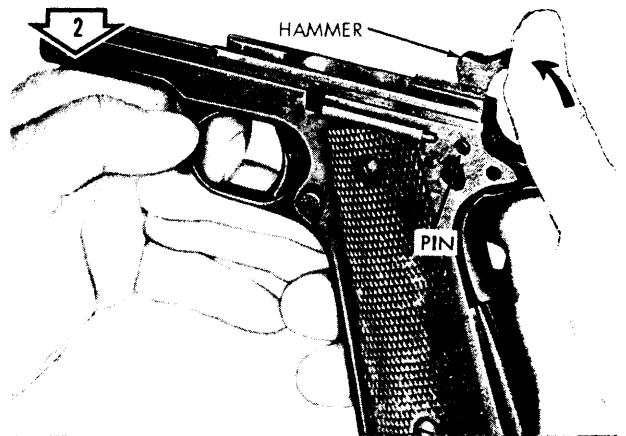

RELEASE HAMMER PRIOR TO REMOVING HAMMER PIN.

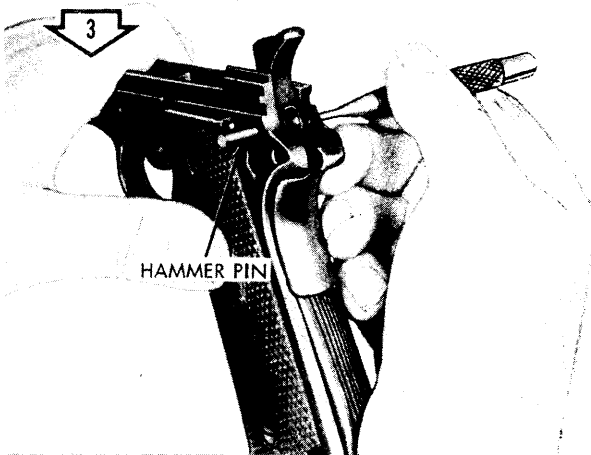

REMOVE HAMMER PIN.

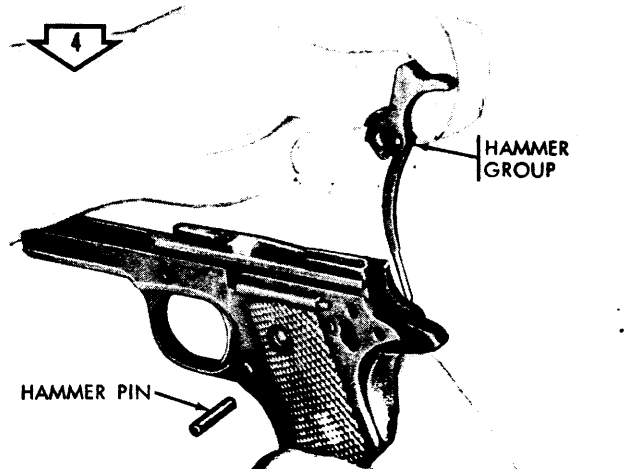

REMOVE HAMMER GROUP.

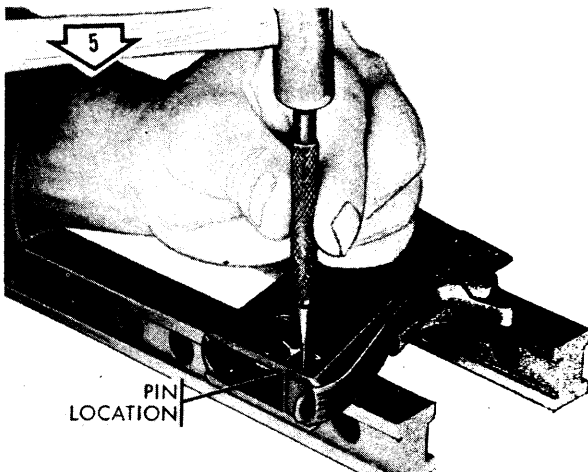

REMOVE MAINSPRING HOUSING PIN.

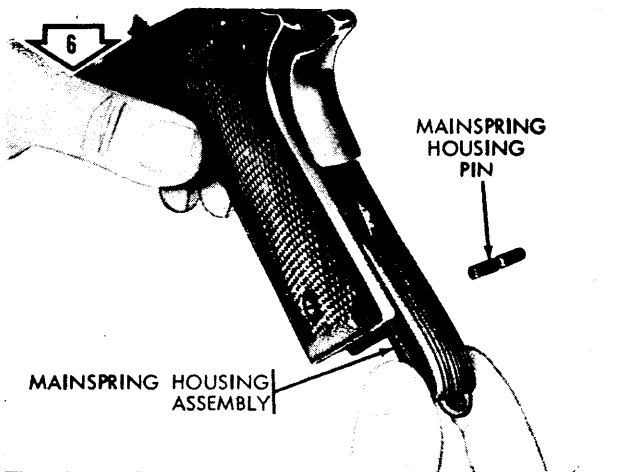

REMOVE MAINSPRING HOUSING ASSEMBLY.

ORD F6622

Figure 26. Disassembly/assembly of receiver group (1 of 7).

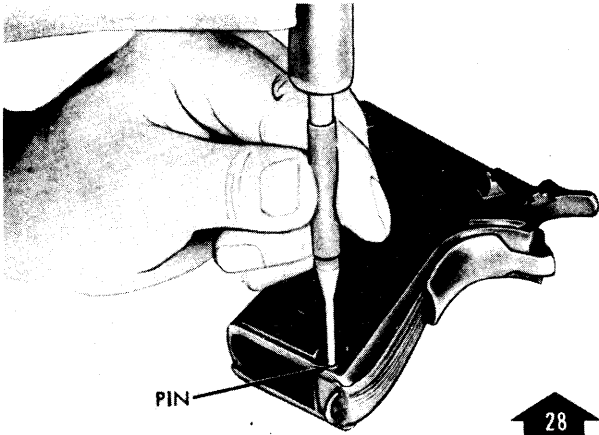

INSTALL MAINSPRING HOUSING PIN.

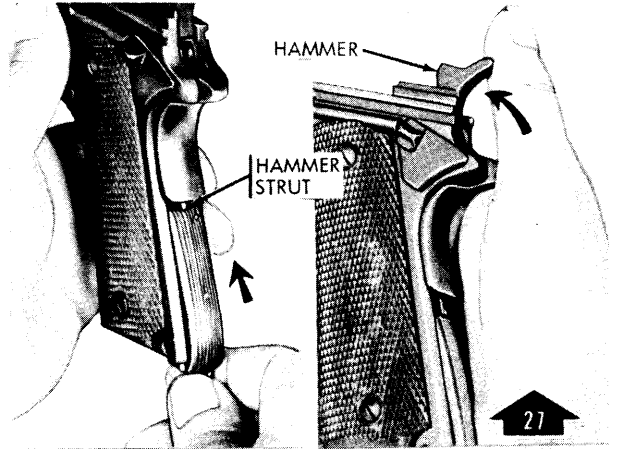

RELEASE HAMMER AND POSITION HAMMER STRUT INTO MAINSPRING HOUSING ASSEMBLY.

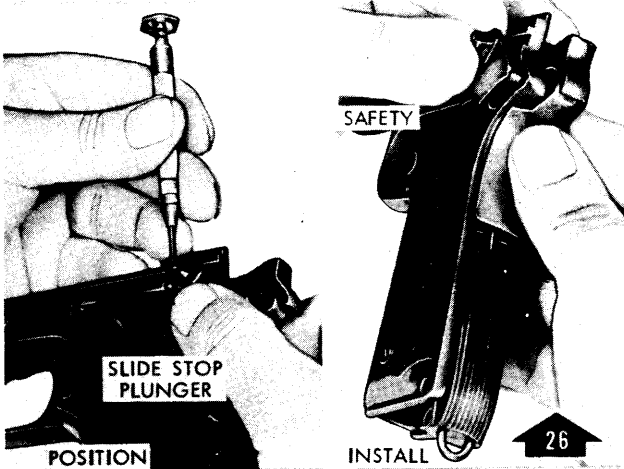

INSTALL AND POSITION SAFETY.

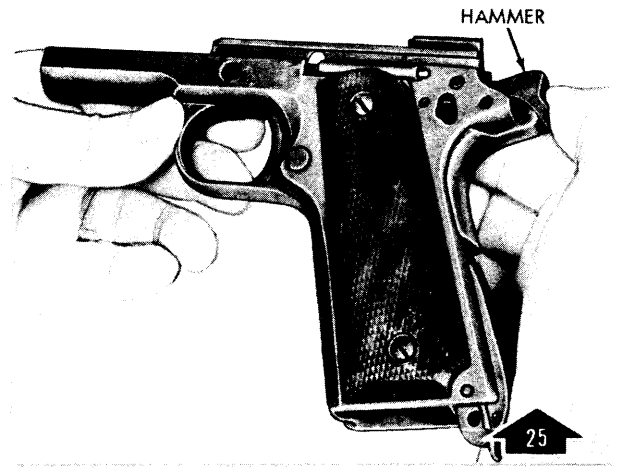

COCK HAMMER PRIOR TO INSTALLING SAFETY.

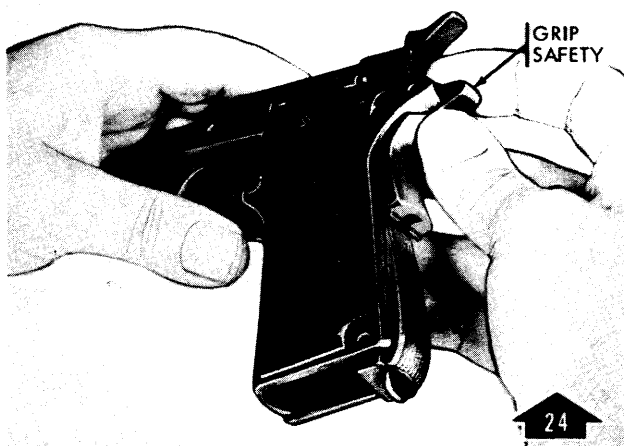

DROP HAMMER STRUT AND INSTALL GRIP SAFETY.



PARTIALLY INSTALL MAINSPRING HOUSING ASSEMBLY TO HOLD SEAR SPRING IN POSITION.

ORD F6623

Figure 27. Disassembly/assembly of receiver group (2 of 7).

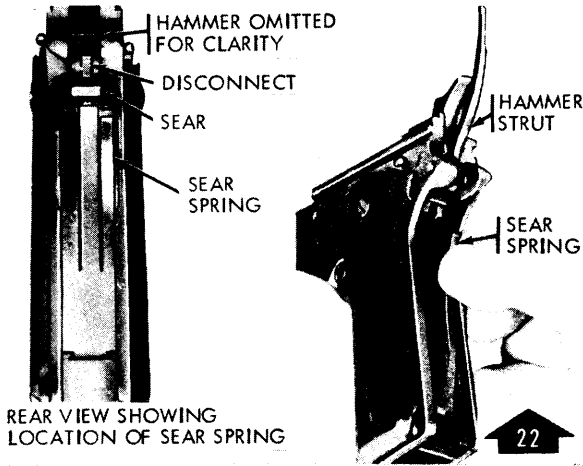

REAR VIEW SHOWING LOCATION OF SEAR SPRING

RAISE HAMMER STRUT AND INSTALL SEAR SPRING.

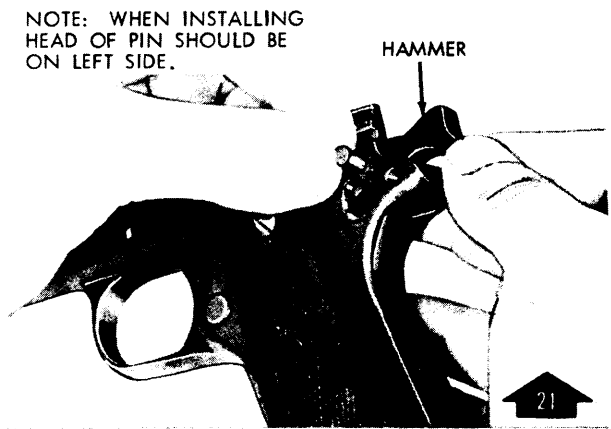

INSTALL HAMMER AND HAMMER PIN.

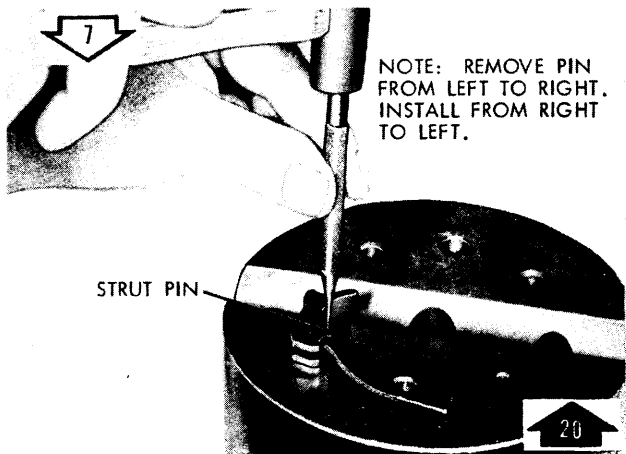

NOTE: REMOVE PIN FROM LEFT TO RIGHT. INSTALL FROM RIGHT TO LEFT.

REMOVE/INSTALL HAMMER STRUT PIN.

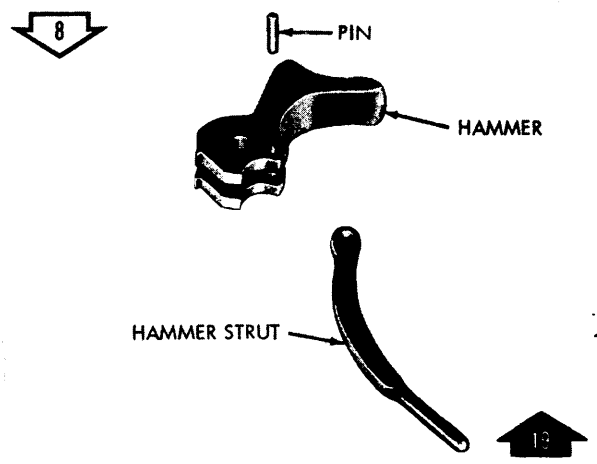

SEPARATE/CONNECT HAMMER STRUT AND HAMMER.

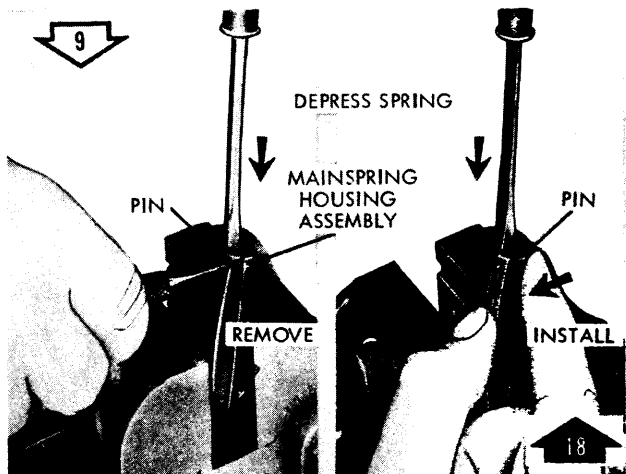

REMOVE/INSTALL STRAIGHT HEADED PIN.

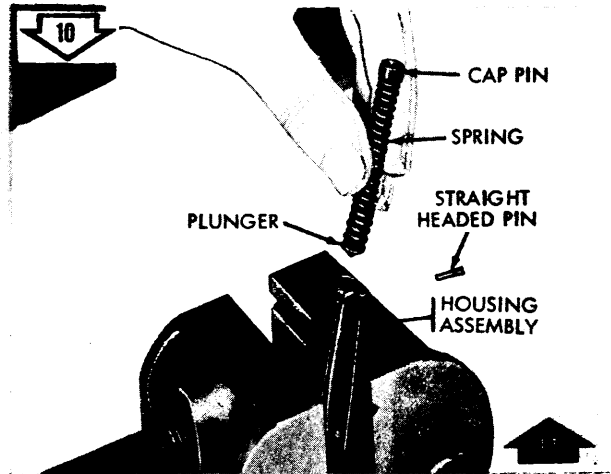

REMOVE/INSTALL MAINSPRING, CAP PIN, HELICAL COMPRESSION SPRING AND DETENT PLUNGER.

ORD F6624

Figure 28. Disassembly/assembly of receiver group (3 of 7).

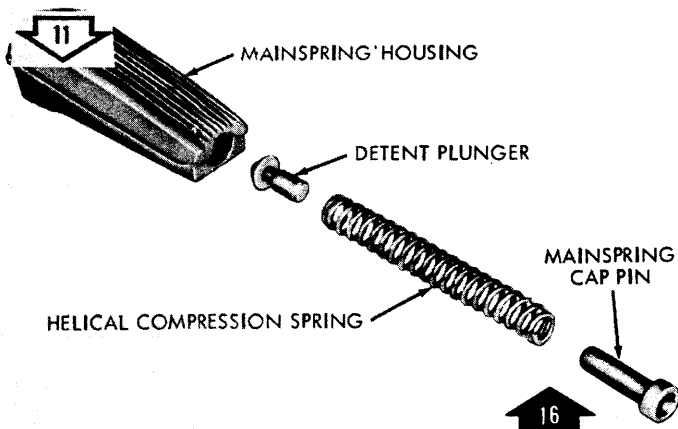

11 SEPARATE/CONNECT DETENT PLUNGER, HELICAL COMPRESSION SPRING AND MAINSRING CAP PIN.

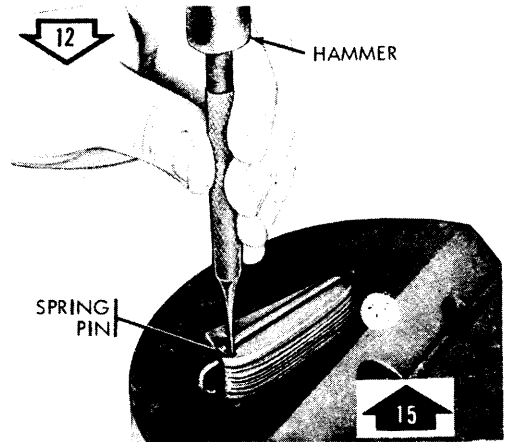

12 REMOVE/INSTALL LANYARD LOOP SPRING PIN.

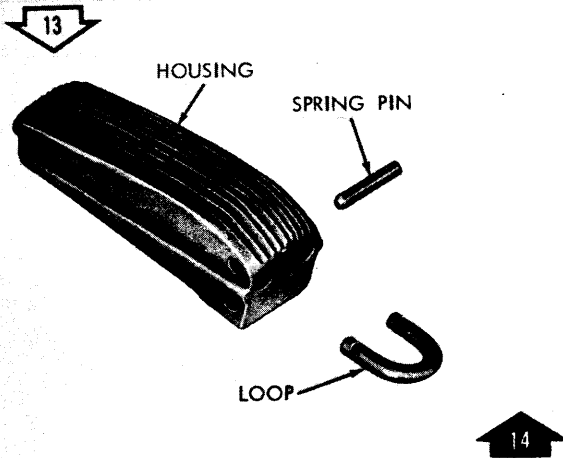

13 SEPARATE/CONNECT LANYARD LOOP.

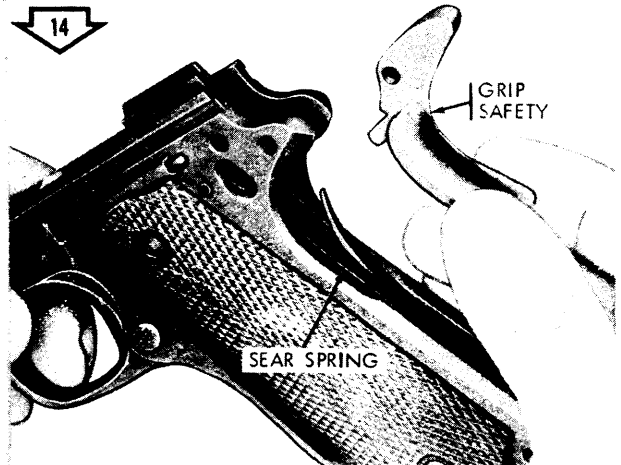

14 REMOVE GRIP SAFETY.

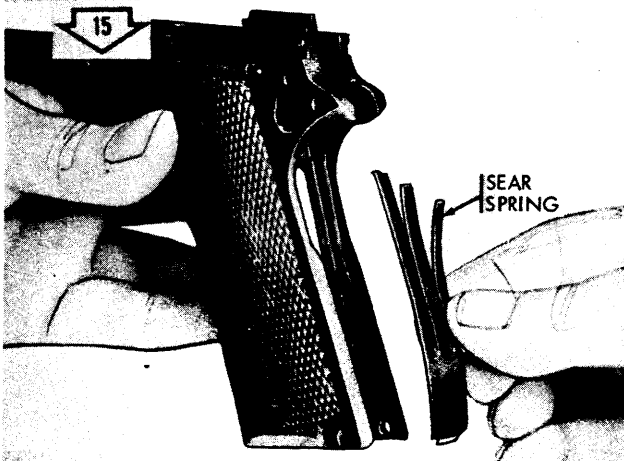

15 REMOVE SEAR SPRING.

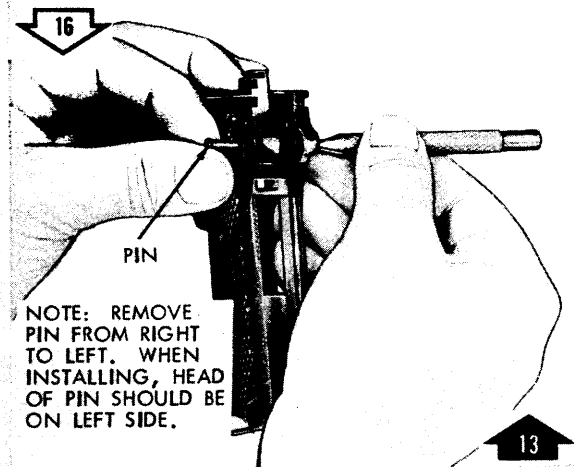

16 REMOVE/INSTALL SEAR PIN.

ORD F6625

Figure 29. Disassembly/assembly of receiver group (4 of 7).

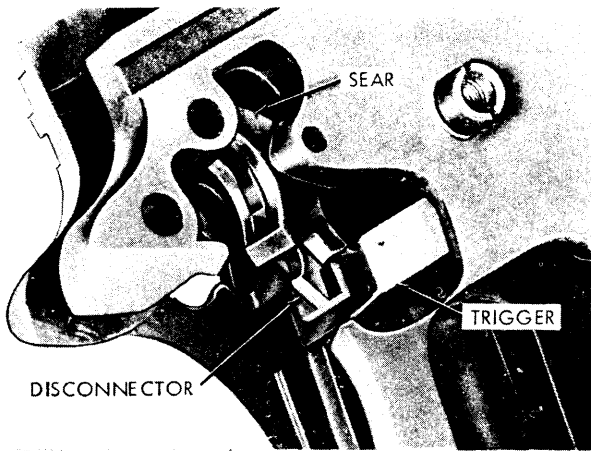

CUTAWAY VIEW SHOWING LOCATION OF SEAR AND DISCONNECTOR.

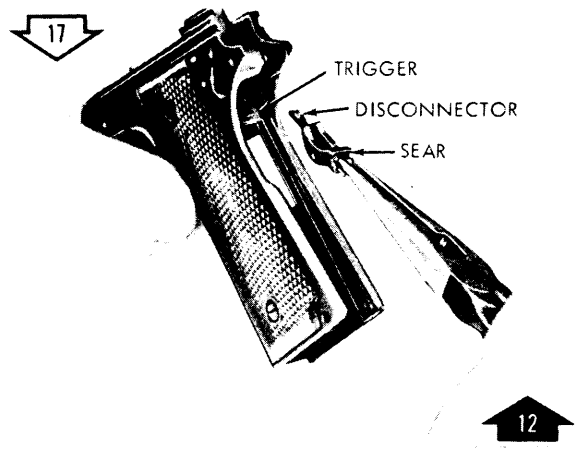

REMOVE/INSTALL SEAR AND DISCONNECTOR.

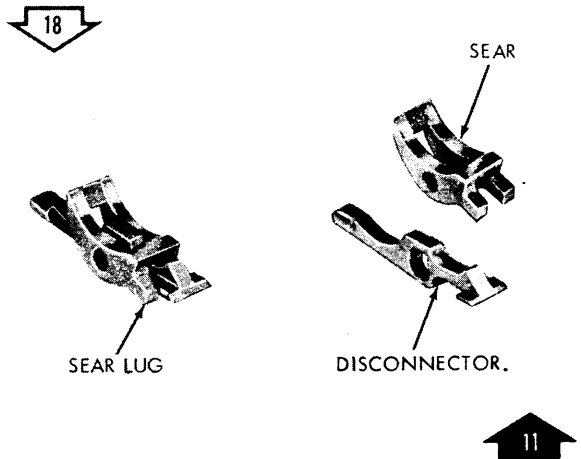

SEPARATE/CONNECT SEAR AND DISCONNECTOR.

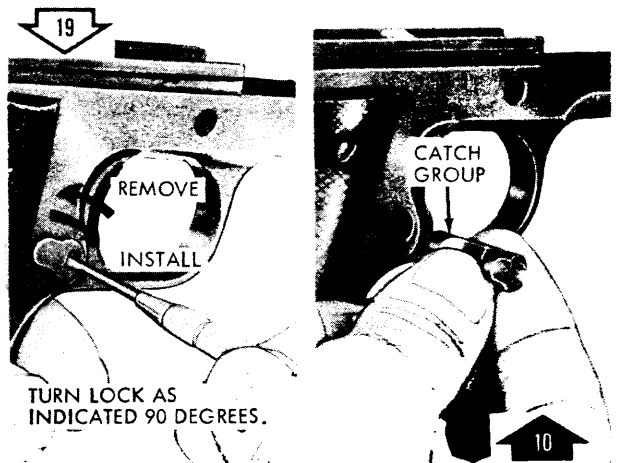

TURN LOCK AS INDICATED 90 DEGREES.

UNLOCK/LOCK CATCH GROUP
REMOVE/INSTALL MAGAZINE CATCH GROUP.

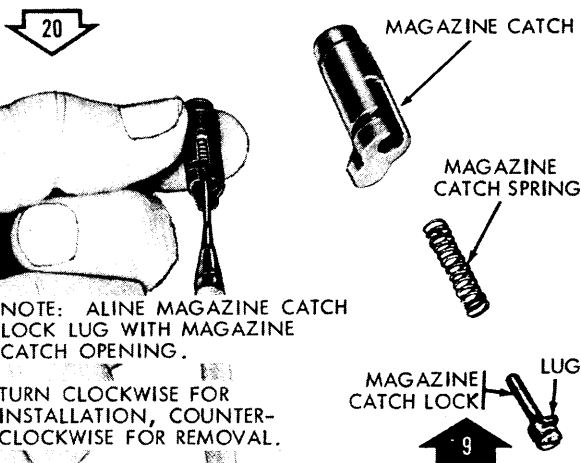

NOTE: ALINE MAGAZINE CATCH LOCK LUG WITH MAGAZINE CATCH OPENING.

TURN CLOCKWISE FOR INSTALLATION, COUNTER-CLOCKWISE FOR REMOVAL.

SEPARATE/CONNECT MAGAZINE CATCH LOCK AND MAGAZINE CATCH SPRING.

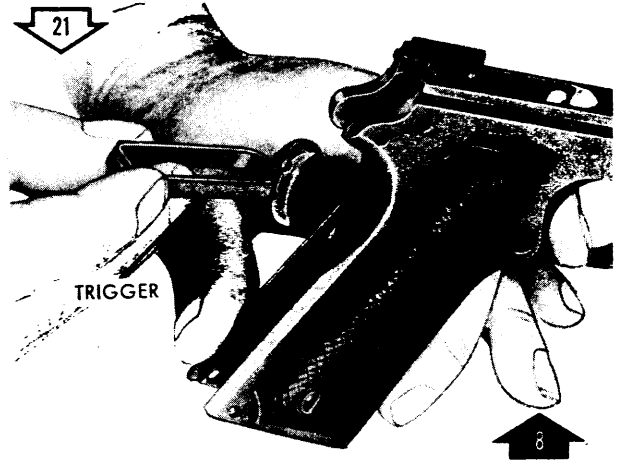

REMOVE/INSTALL TRIGGER.

ORD F6626

Figure 30. Disassembly/assembly of receiver group (5 of 7).

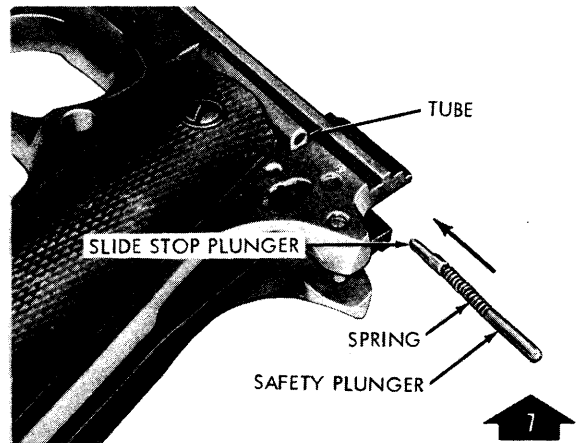
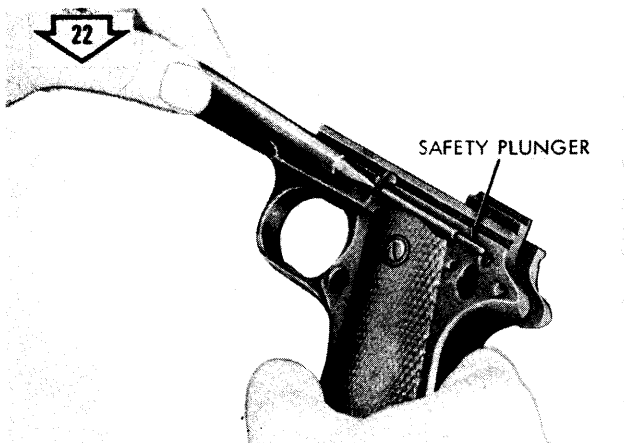

REMOVE/INSTALL SLIDE STOP PLUNGER, HELICAL COMPRESSION SPRING AND SAFETY PLUNGER.

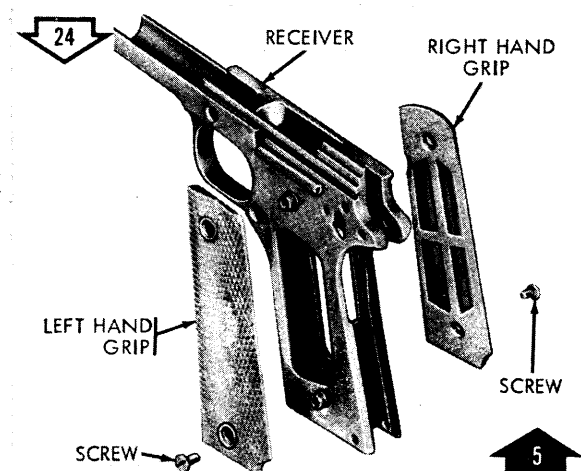
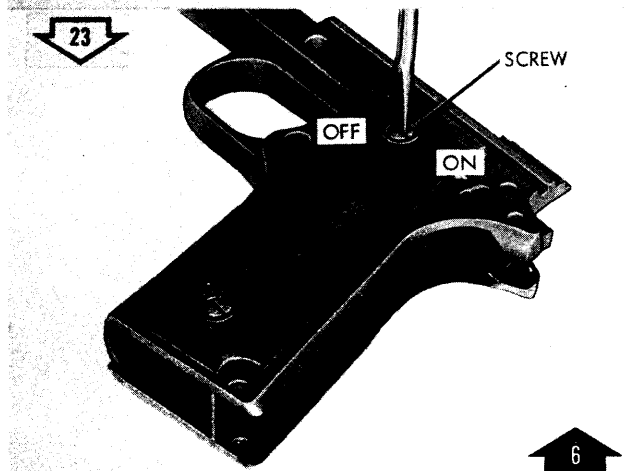

REMOVE/INSTALL GRIP SCREWS.

REMOVE/INSTALL PLASTIC GRIPS.

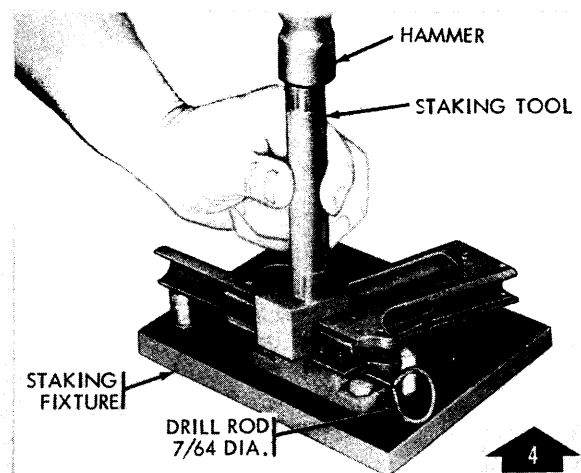
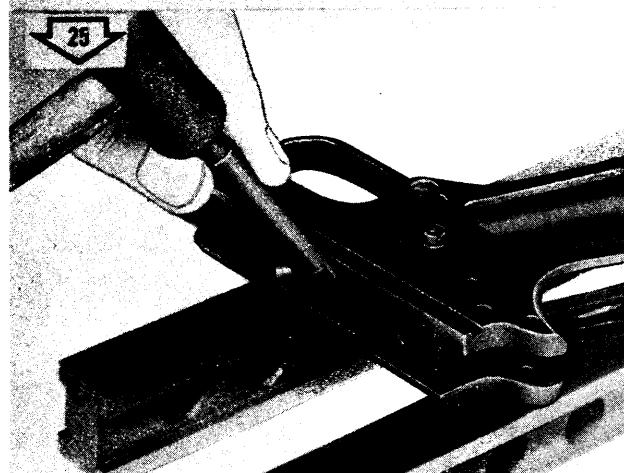

UNSEATING PLUNGER TUBE.

INSTALL/STAKE PLUNGER TUBE ON RECEIVER.

ORD F6627

Figure 31. Disassembly/assembly of receiver group (6 of 7).

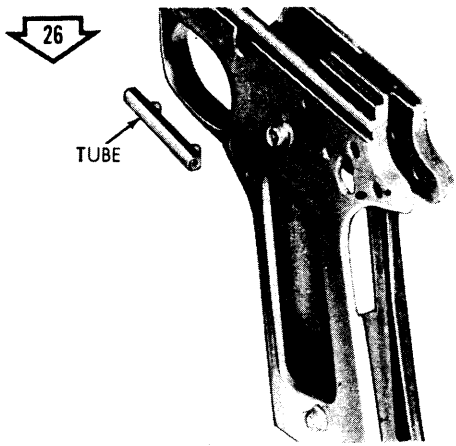

REMOVE PLUNGER TUBE.

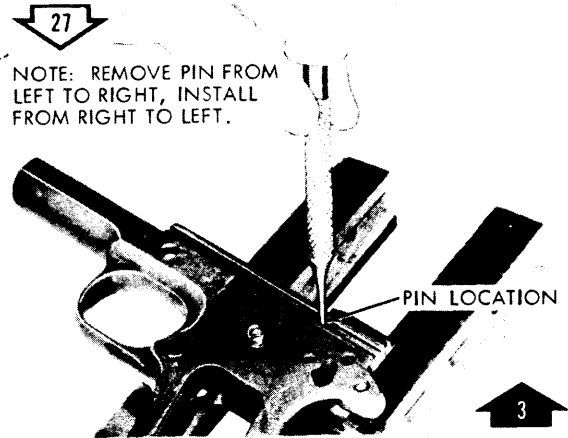

REMOVE/INSTALL EJECTOR PIN.

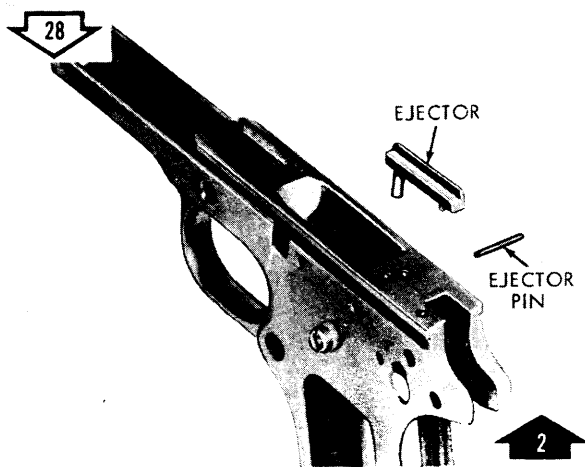

REMOVE/INSTALL CARTRIDGE EJECTOR.

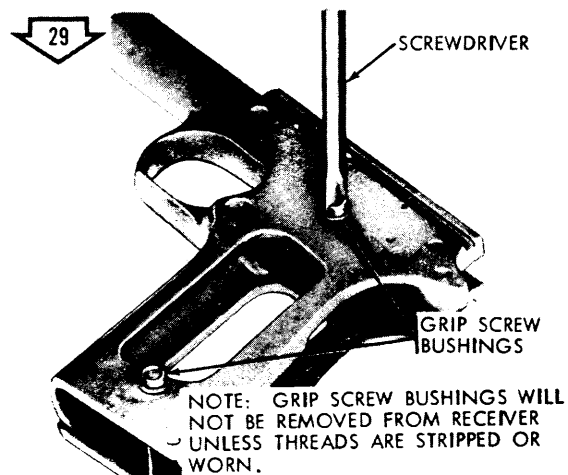

REMOVE GRIP SCREW BUSHINGS.

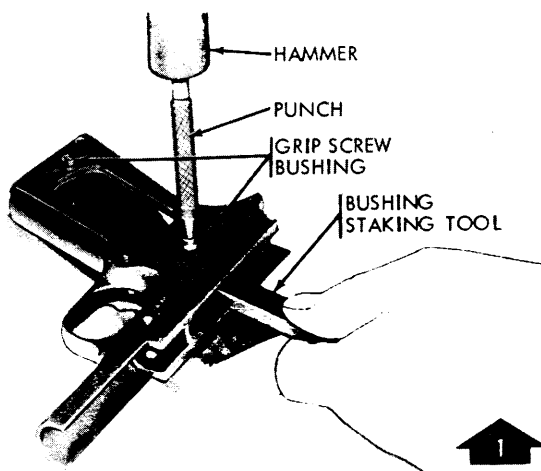

INSTALL AND STAKE GRIP SCREW BUSHINGS

Figure 32. Disassembly/assembly of receiver group (7 of 7).

ORD F6628

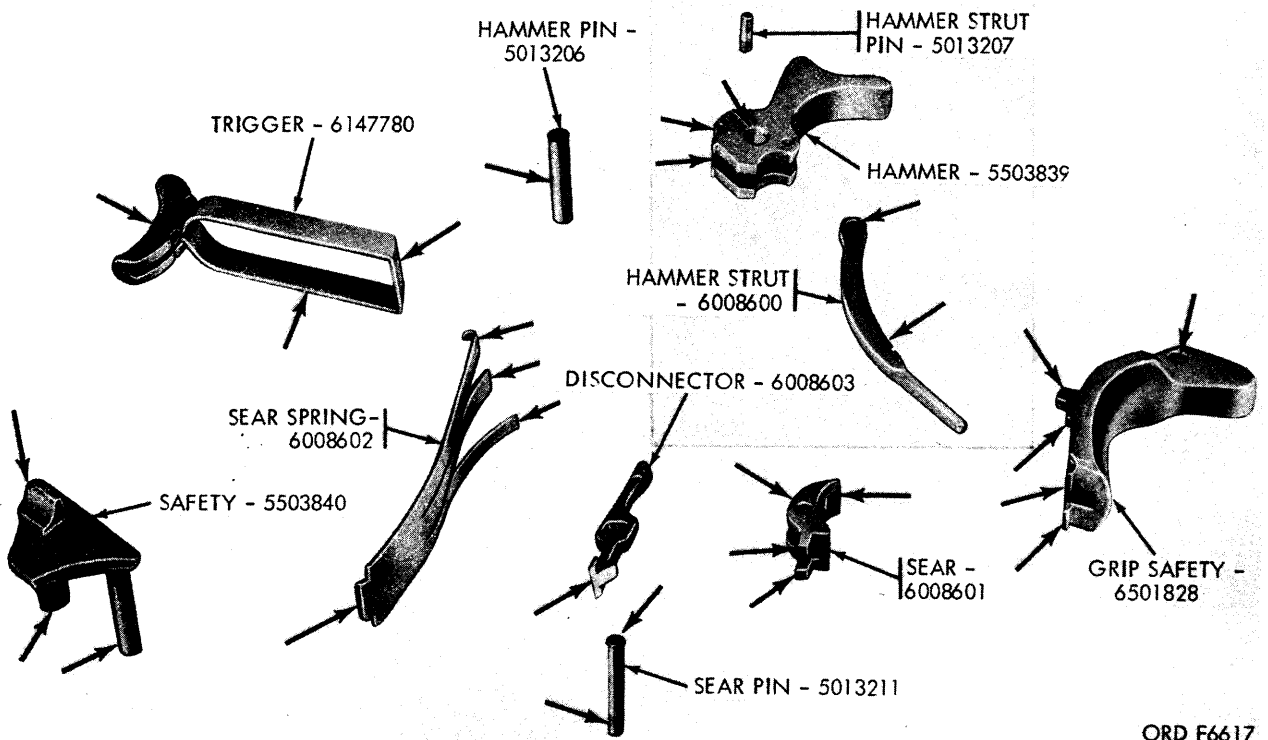

ORD F6617

Figure 33. Receiver group - inspection points (1 of 3).

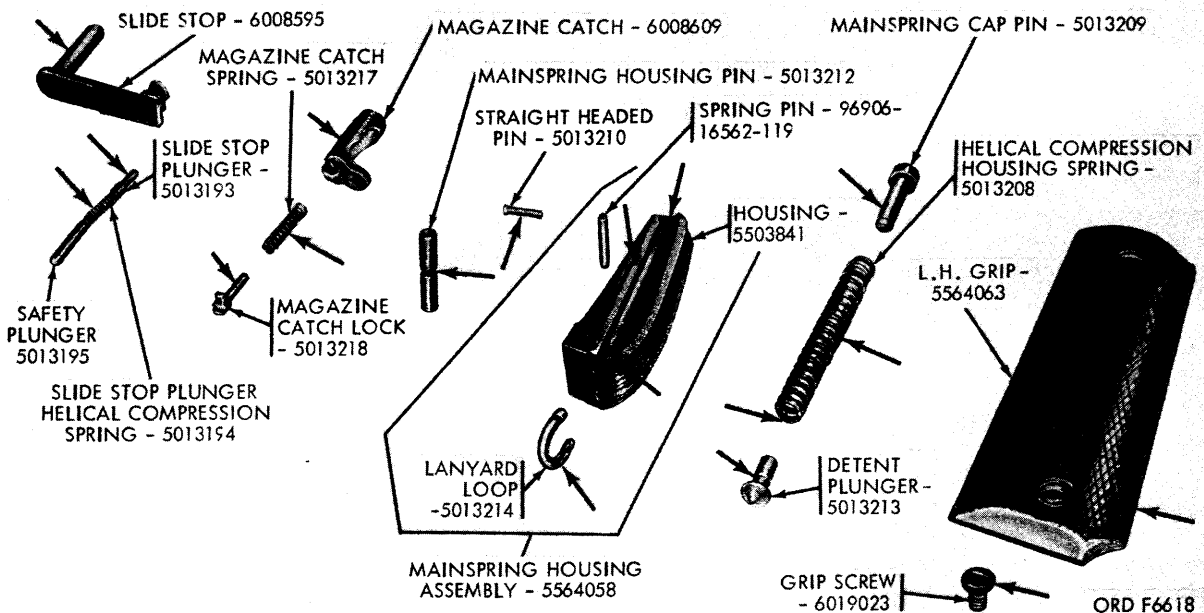

ORD F6618

Figure 34. Receiver group - inspection points (2 of 3).

spring (housing), if damaged or tension is weak.

1. Remove burrs from mainspring cap pin, detent plunger, and straight headed

pin. Replace, if worn or damaged.

m. Replace mainspring housing pin and spring pin if bent or worn.

n. Remove burrs from slide stop, slide

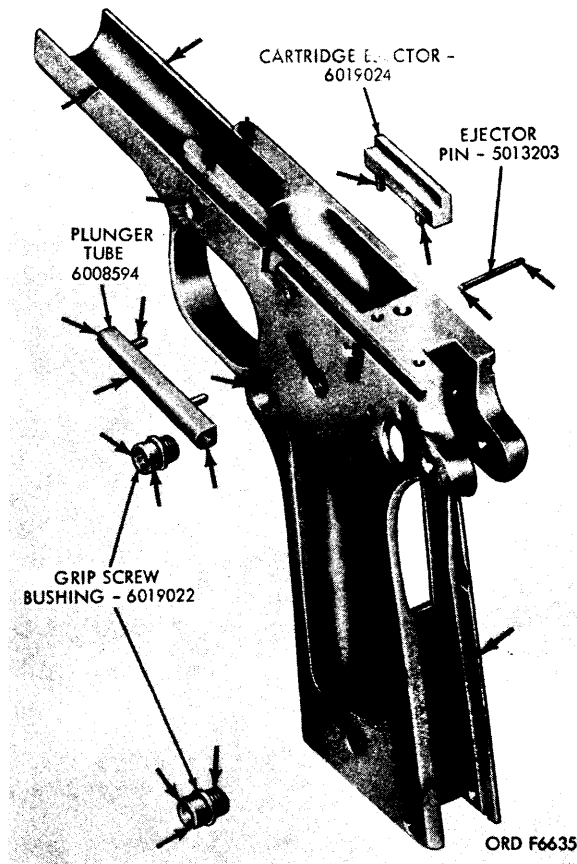

Figure 35. Receiver group - inspection points (3 of 3).

stop plunger and safety plunger. Replace, if worn or damaged.

o. Remove burs from magazine catch and magazine catch lock. Replace if worn. Replace magazine catch spring if damaged or tension is weak.

p. Remove burs from the mating surfaces and mainspring housing. Replace lanyard loop if bent or damaged.

q. Replace grips if broken or checkering is worn.

38. Assembly

Refer to figures 26 thru 32 for assembling of receiver group.

CHAPTER 6

FINAL INSPECTION

39. General

Pistols turned in for repair may be assumed to have defects caused by use or neglect. When they were accepted as new weapons, the parts composing them were dimensionally correct and made of the proper material. The inspection of these weapons after repair will differ from the inspection procedure used in the manufacturing plant in that attention will be directed to wearing surfaces, parts that might crack or break due to high stress or fatigue, and evidences of corrosion. These defects do not evidence themselves by uniform reduction in a given dimension but show up as a chipped edge, a partially worn surface, or an eccentric hole. A gage used in manufacturing is merely a means of comparing an unknown dimension with a known one to judge whether a piece comes within tolerances. After this piece is worn through use, the change in dimension is more easily detected in many cases by comparing with adjacent surfaces; the piece in itself becomes a gage. Visual inspection, therefore, is far more applicable in these cases and gaging is limited to those dimensions that are critical or that may be more advantageously measured than compared. Inspection of non-critical parts (parts that do not ordinarily cause malfunctions) will be limited to appearance and the presence of cracks or flaws. The dimensions and tolerances placed on the parts (and gaging used during manufacturing) were for the sole purpose of insuring interchangeability. Even if the dimensions of such parts are worn considerably below drawing tolerance, functioning and interchangeability will not be adversely affected and the parts are consequently acceptable. The serviceability of the material must also be determined by conducting inspection as described in paragraphs 13 through 16.

40. Specific Inspection Procedures

a. Visual Inspection. Visual and overall appearance of the pistol should be approximately that of a new weapon. All exposed metal surfaces are to have a phosphate-finish. The color will range from black to medium light gray. Bright surfaces are objectionable from standpoint of visibility when they are capable of reflecting light. All outside surfaces will be free of burs or deep scratches. Barrels must be straight, clean and free of rust and powder fouling and free from bulges and rings. Pistols must be complete. All applicable modifications must be applied. The serial number must be legible and all parts must be free of rust. Visually inspect the following:

- (1) Check front and rear sights, make certain they are tight and properly alined.
- (2) Check for split or damaged plastic grips and loose grip screws.

b. Functional Inspection.

- (1) Check functioning of safety. Refer to paragraph 15c(1).
- (2) Check functioning of grip safety. Refer to paragraph 15c(2).
- (3) Check functioning of hammer or sear. Refer to paragraph 15c(3).
- (4) Check functioning of disconnecter. Refer to paragraph 15c(4).
- (5) Upon completion of inspection, pistols will be properly cleaned and lubricated (paragraphs 19 and 23).

c. Trigger Pull Test. Check the trigger pull using trigger pull measuring fixture (figs. 5 and 36) and in accordance with instructions indicated in (1) and (2) below:

- (1) With the safety unlocked, rest the weight on the floor and hook the notched portion of the rod over the center portion of the trigger.

Note. Make certain the rod does not contact or rub any portion of the pistol and that

rod and barrel are parallel. Empty magazine must be installed when checking trigger pull.

- (2) Depress grip safety and carefully raise the weight from the floor. When using the 5 pound weight (minimum), the trigger should not release the hammer. When using the 6.5 pound weight (maximum), the trigger should release the hammer.

Caution: A slow or steady lift must be utilized to assure a true and accurate check.

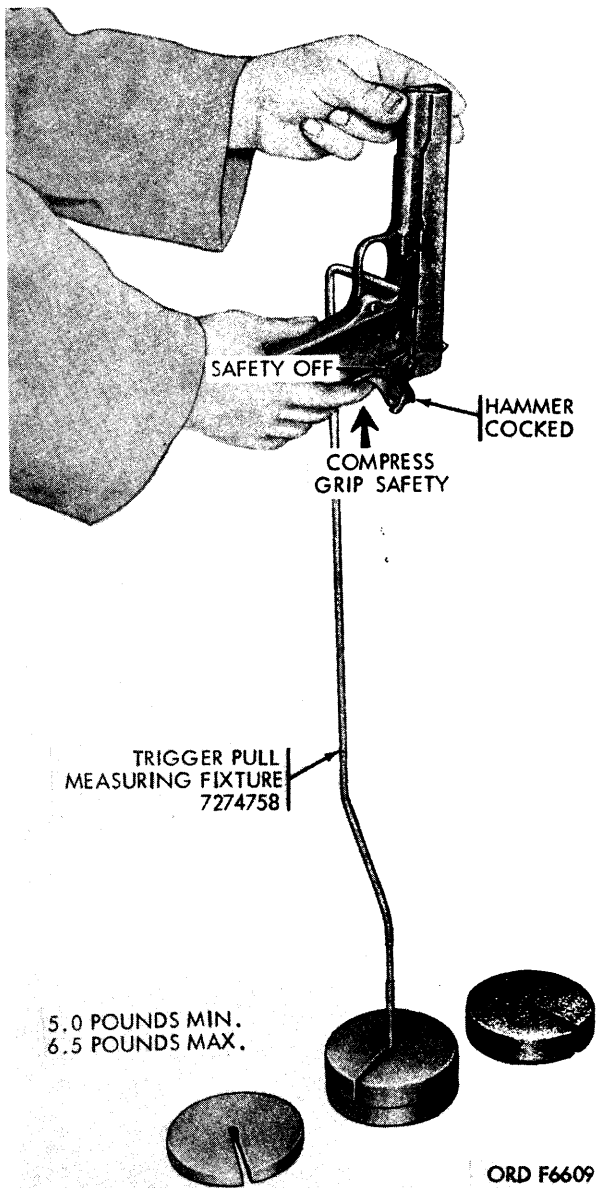

Figure 36. Checking trigger pull.

d. Correcting Trigger Pull.

- (1) **Trigger pull too light.** This is evidence of a worn cocking notch on the hammer, worn or damaged sear or a weak helical compression housing spring. Examine the components for wear or damage. If trigger pull cannot be corrected by stoning, replace with new components as required.
- (2) **Trigger pull excessive.** This is evidence of burs or surface irregularities on the hammer full-cock notch or sear. A helical housing spring that is damaged or too strong and/or interferences or binding between the mating surfaces of the pertinent parts within the receiver group are other probable causes. If the trigger pull cannot be corrected by stoning, replace with new components as required.
- (3) **Creep in trigger.** Creep is defined as a perceptible movement of the trigger after the slack has been taken up and before the hammer is released. It is caused by rough or uneven mating surfaces of the sear, hammer, and disconnecter and also by unserviceable sear and hammer pins. If the creep cannot be corrected by stoning, replace with new components as required.

Caution: While stoning, critical dimensions should not be altered.

e. Hand Function Test.

- (1) Place three dummy cartridges in magazine (fig. 37). Insert magazine in receiver group. Release slide stop. This action would cause barrel and slide group to move forward. At the same time, a dummy cartridge will be stripped from magazine into chamber of the weapon.
- (2) Release safety (fig. 38).
- (3) Squeeze trigger, allowing hammer to fall (fig. 39). Continue test until third cartridge has been ejected from the pistol, simulating dry firing.
- (4) When last cartridge is ejected, slide group should remain locked

in open position by slide stop (fig. 40).

(5) Pistols that fail to meet the re-

quired functioning test will be corrected by replacement of defective components.

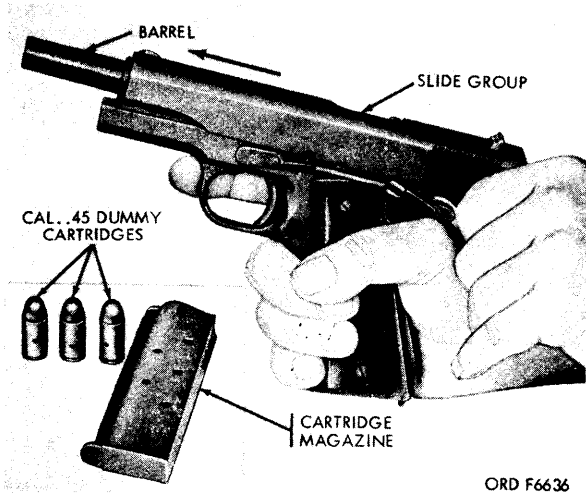

Figure 37. Position of hands when loading weapon - left front view.

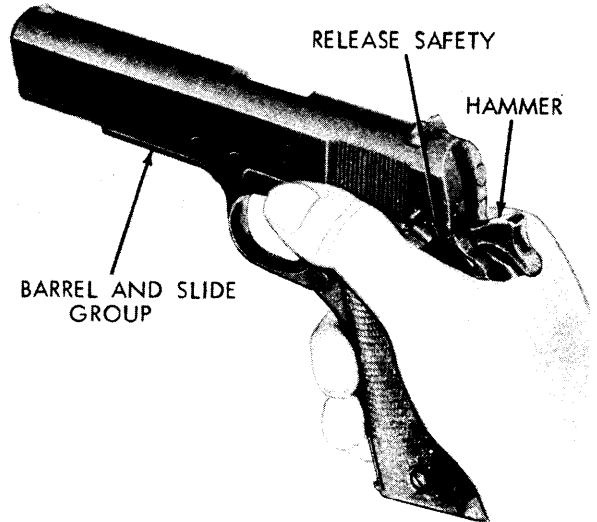

Figure 38. Hammer cocked - ready to begin function firing.

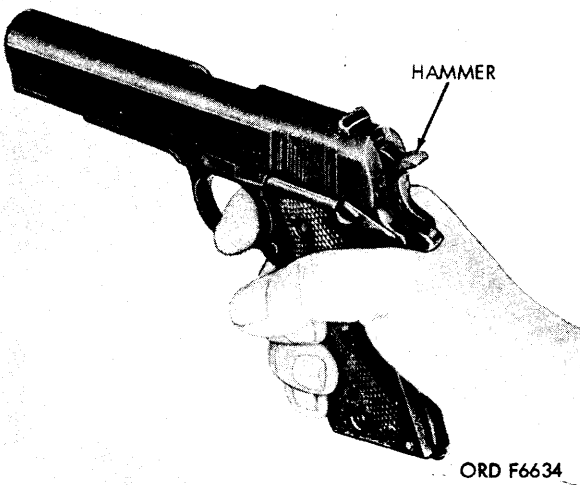

Figure 39. Weapon in battery position.

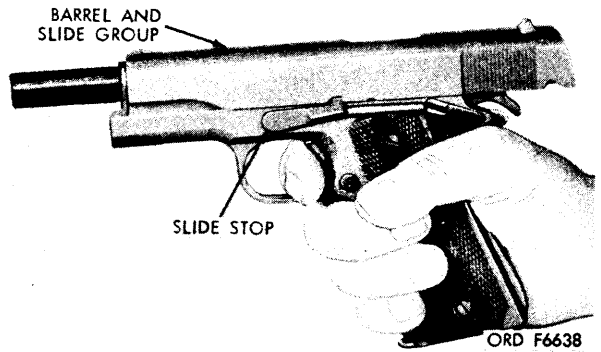

Figure 40. Slide group locked in open position after last cartridge is fired.

CHAPTER 7

PREPARATION AND SHIPPING INSTRUCTIONS

41. Preparation

a. Cleaning. All metal parts shall be thoroughly cleaned by process C-3 of Specification MIL-P-116C. Surfaces of parts subjected to burned powder residues will be cleaned with solvent cleaning compound (PD 126) conforming to Specification MIL-C-372B.

b. Drying. All surfaces will be thoroughly dried by wiping with clean cloths or by blowing the surface with a blast of clean dry compressed air from a line equipped with filter moisture traps.

c. Preservation. Pistols will be coated with a lubricating oil (PL special) making certain all surfaces are covered, including the entire bore of barrel.

d. Packaging. Each pistol will be individually wrapped in a heavy-duty grease-proof paper. All protruding edges will be cushioned, using several thicknesses of grease-proof paper prior to wrapping.

e. Packing. Pack a maximum of 50 pistols in a suitable wood container box.

Make certain they are adequately blocked to prevent movement during handling and shipping. After closure, apply two flat steel straps around the box.

Note. For further pertinent information and guidance in preservation, packaging and packing of the above named materiel, refer to TM 38-230.

42. Marking Instructions

Standard and precautionary markings will be applied to boxes as prescribed in TM 9-200.

43. Shipping Instructions

a. Responsibility. When shipping the pistol the officer-in-charge of preparing the shipment will be responsible for properly processing the materiel for shipment, including the preparation of Army shipping documents.

b. Army Shipping Documents. Prepare all Army shipping documents in accordance with AR 725-50.

APPENDIX

REFERENCES

1. Publication Indexes

The following indexes will be consulted frequently for the latest changes or revisions of references given in this appendix and for new publications relating to materiel covered in this manual.

Military Publications:

Index of Administrative Publications	DA Pam 310-1
Index of Army Motion Pictures, Film Strips, Slides, and Phono-Recordings.	DA Pam 108-1
Index of Blank Forms	DA Pam 310-2
Index of Graphic Training Aids and Devices	DA Pam 310-5
Index of Supply Manuals: Ordnance Corps	DA Pam 310-29
Index of Technical Manuals, Technical Bulletins, Supply Manuals, (types 4, 6, 7, 8 and 9), Supply Bulletins, Lubrication Orders, and Modification Work Orders.	DA Pam 310-4
Index of Doctrinal, Training, and Organizational Publications	DA Pam 310-3

2. Supply Manuals

The following supply manuals of the Department of the Army supply manuals pertain to this materiel:

Operator and Organizational Maintenance Repair Parts and Special Tool Lists for Pistol, Caliber .45, Automatic, M1911A1 with Holster, Hip and Pistol, Caliber .45, Automatic, M1911A1 with Holster, Shoulder.	TM 9-1005-211-12P/2
Direct and General Support Maintenance Repair Parts and Special Tool Lists for Pistol, Caliber .45, Automatic, M1911A1 with Holster, Hip and Pistol, Caliber .45, Automatic, M1911A1 with Holster, Shoulder.	TM 9-1005-211-35P

3. Forms

The following forms pertain to this materiel.

DA Form 2028, Recommended Changes to DA Technical Manual Parts Lists or Supply Manual (cut sheet).	
DA Form 2407, Maintenance Request.	
DD Form 6, Report of Damaged or Improper Shipment (cut sheet).	

4. Other Publications

The following explanatory publications pertain to this materiel.

a. General.

The Army Equipment Record System and Procedures	TM 38-750
Military Training	FM 21-5
Techniques of Military Instruction	FM 21-6
Military Symbols	FM 21-30
Military Terms, Abbreviations, and Symbols Authorized Abbreviations and Brevity Codes.	AR 320-50

Dictionary of United States Army Terms	AR 320-5
<i>b. Cleaning.</i>	
Cleaning of Ordnance Materiel	TM 9-208-1
Cleaning and Black Finishing of Ferrous Metals	TM 9-1861
Cleaning Compound, Solvent (For Bore of Small Arms and Automatic Aircraft Weapons).	MIL-C-372B
<i>c. Inspection.</i>	
Command Maintenance Management Inspections	AR 750-8
Field Inspection and Serviceability Standards for Small Arms Materiel.	TB ORD 587
<i>d. Issue of Supplies and Equipment.</i>	
Requisitioning, Receipts, and Issue System	AR 725-50
<i>e. Logistics.</i>	
Malfunctions Involving Ammunition and Explosives	AR 700-1300-8
<i>f. Maintenance of Supplies and Equipment.</i>	
Organization Policies and Responsibilities for Maintenance Operations.	AR 750-5
<i>g. Packaging and Preservation.</i>	
General Packaging Instructions for Ordnance General Supplies	TM 9-200
Preservation, Packaging, and Packing of Military Supplies and Equipment.	TM 38-230
Preservation, Methods of	MIL-P-116C
<i>h. Safety.</i>	
Accident Reporting and Records	AR 385-40

INDEX

	Paragraphs	Page		Paragraphs	Page
Assembly of barrel and slide group -----	33	28	Inspection, scope of -----	11	12
Assembly of receiver group -----	38	37	Installation of cartridge magazine -----	28	21
Barrel and slide group, assembly (See Assembly of barrel and slide group)			Lubrication -----	23	19
Barrel and slide group, cleaning -----	30	22	Maintenance allocation, direct and general support -----	2	2
Barrel and slide group, disassembly -----	29	22	Maintenance, general (See General maintenance)		
Barrel and slide group, inspection -----	31	22	Maintenance parts -----	7	7
Barrel and slide group, repair -----	32	26	Manual, scope of -----	1	2
Burs, screwheads and working surfaces, removal of -----	22	19	Marking instructions -----	42	41
Cartridge magazine, cleaning -----	26	21	Materiel in the hands of troops, inspection of -----	15	13
Cartridge magazine, disassembly -----	25	21	Ordnance shop inspections -----	16	15
Cartridge magazine, inspection -----	27	21	Parts, maintenance -----	7	7
Cartridge magazine, installation -----	28	21	Precautions in cleaning, general -----	20	19
Cartridge magazine, removal -----	24	21	Preparation and shipping instructions:		
Categories of inspection -----	13	13	Marking instructions -----	42	41
Cleaning -----	19	18	Preparation -----	41	41
Cleaning of barrel and slide group -----	30	22	Shipping instructions -----	43	41
Cleaning of cartridge magazine (See Cartridge magazine, cleaning)			Preparation instructions, shipping -----	41	41
Cleaning of receiver group -----	35	28	Purpose of inspection -----	12	12
Common tools and equipment -----	8	7	Receiver group, assembly -----	38	37
Data, tabulated (See Tabulated data)			Receiver group, cleaning -----	35	28
Description -----	4	3	Receiver group, disassembly -----	34	28
Direct and general support maintenance allocation -----	2	2	Receiver group, inspection of -----	36	28
Disassembly of barrel and slide group -----	29	22	Receiver group, repair -----	37	28
Disassembly of cartridge magazine -----	25	21	Records and reports, forms -----	3	2
Disassembly of receiver group -----	34	28	Removal of burs, screwheads and working surfaces -----	22	19
Final inspection, general (See General, final inspection)			Removal of cartridge magazine -----	24	21
Finished surfaces -----	21	19	Repair methods, general (See General repair methods)		
Forms, records, and reports -----	3	2	Repair of barrel and slide group -----	32	26
General, final inspection -----	39	38	Repair of receiver group -----	37	28
General, inspecting procedures -----	14	13	Scope of inspection -----	11	12
General, tools and equipment -----	6	7	Scope of manual -----	1	2
General maintenance -----	17	18	Shipping instructions -----	43	41
General precautions in cleaning -----	20	19	Special tools and equipment -----	9	7
General repair methods -----	18	18	Specific inspection procedures -----	40	38
Improvised tools -----	10	7	Surfaces, finished (See Finished surfaces)		
Inspection, categories of -----	13	12	Tables:		
Inspection of barrel and slide group -----	31	22	Improvised tools (table 2) -----	10	7
Inspection of cartridge magazine -----	27	21	Special tools and equipment (table 1) -----	9	7
Inspection of materiel in the hands of troops -----	15	13	Troubleshooting (table 3) -----	16	15
Inspection of receiver group -----	36	28	Tabulated data -----	5	3
Inspections, Ordnance shop (See Ordnance shop inspections)			Tools and equipment, common (See Common tools and equipment)		
Inspection procedures, general (See General inspection procedures)			Tools and equipment, general (See General tools and equipment)		
Inspection procedures, specific (See Specific inspection procedures)			Tools and equipment, special (See Special tools and equipment)		
Inspection, purpose of -----	12	12	Tools, improvised -----	10	7

By Order of Secretary of the Army:

EARLE G. WHEELER,
*General, United States Army,
Chief of Staff.*

Official:

J. C. LAMBERT,
*Major General, United States Army,
The Adjutant General.*

Distribution:

Active Army:

USASA (2)
DCSLOG (1)
CNGB (1)
C/COMMEL (1)
USA Ord CD Agcy (2)
CofEngrs (1)
TSG (1)
USCONARC (3)
ARADCOM (2)
ARADCOM Rgn (2)
OS Maj Comd (2) except
 USAREUR (3)
 USARJ (3)
USAMC (5)
USAWECOM (60)
USAMICOM (2)
USAMUCOM (2)
USAECOM (2)
USAMOCOM (2)
USASMCOM (1)
USATECOM (2)
USAATBD (3)
USAOCCA (2)
OS Base Comd (2)
MDW (2)
LOGCOMD (2)

Armies (3) except
 Sixth (1)
Corps (2)
USA Corps (2)
Div (2)
Bde (2)
Regt/Gp/BG (2)
Bn (2)
Co/Btry (1) except
 Ord Co (2)
Br Svc Sch (2) except
 Ord Sch (50)
GENDEP (OS) (1)
Ord Sec, GENDEP (OS) (1)
Army Dep (2) except
 Lexington (3)
 Tooele (12)
 Letterkenny (10)
Ord Dep (OS) (2)
USA Tml (1)
POE (1)
USAOSA
Ord PG (10)
Arsenals (5)
Springfield Armory (5)
Proc Dist (2)

NG: State AG (3); Units – same as Active Army except allowance is one copy to each unit.

USAR: Same as Active Army except allowance is one copy to each unit.

For explanation of abbreviations used, see AR 320-50.

TM 9-1005-211-34 PISTOL, CALIBER .45, AUTOMATIC, M1911A1